

# 目录 INDEX

类别 TYPE	代号 PART NO	页次 PAGE
公制外螺纹O型圈平面密封 METRIC MALE O-RING	1E	1
90° 公制外螺纹O型圈平面密封 90° METRIC MALE O-RING	1E9	2
90° 公制螺纹O型圈平面密封 90° METRIC MALE O-RING	2E9	2
公制外螺纹O型圈平面密封堵头 METRIC MALE O-RING PLUG	4E	3
公制内螺纹平面堵头 METRIC FEMALE FLAT FACE PLUG	9E	4
公制外螺纹O型圈平面密封过板接头 METRIC MALE O-RING BULKHEAD	6E	4
90° 公制外螺纹O型圈平面密封过板接头 90° METRIC MALE O-RING BULKHEAD	6E9	5
公制外螺纹O型圈平面密封重系列 METRIC MALE O-RING	1EH	5
45° 公制外螺纹O型圈平面密封/ 可调向柱端重系列 45° METRIC MALE O-RING/ADJUSTABLE STUD	1EH4-OG	6
90° 公制外螺纹O型圈平面密封/ 可调向柱端重系列 90° METRIC MALE O-RING/ADJUSTABLE STUD	1EH9-OG	6
公制外螺纹O型圈平面密封/ 60° 内锥六角端面组合垫圈 METRIC MALE O-RING/60° SEAT BONDED SEAL	1EM	7
公制外螺纹O型圈/ 布锥管外螺纹 METRIC MALE O-RING/NPT MALE	1EN	7
公制外螺纹O型圈/ 英锥管外螺纹 METRIC MALE O-RING/BSPT MALE	1ET	8
公制外螺纹O型圈平面密封/焊接管 METRIC MALE O-RING/BUTT-WELD TUBE	1EW	9
90° 公制外螺纹O型圈平面密封/焊接管 90° METRIC MALE O-RING/BUTT-WELD TUBE	1EW9	9
公制外螺纹O型圈平面密封/英管螺纹组合垫密封 METRIC MALE O-RING/BSP MALE DIN 3852-2 TYREA	1EZ	10
焊接管/ 公制内螺纹O型圈平面密封 BUTT-WELD TUBE/METRIC FEMALE O-RING	2WE	11
公制外螺纹O型圈平面密封四通接头 METRIC MALE O-RING CROSS	XE	12
公制外螺纹O型圈平面密封三通接头 METRIC MALE O-RING TEE	AE	12
公制外螺纹O型圈/公制内螺纹平面密封三通接头 METRIC MALE O-RING/METRIC FEMALE TEE	BE	13
公制外螺纹O型圈/公制内螺纹平面密封三通接头 METRIC MALE O-RING/METRIC FEMALE TEE	CE	13

# 目录 INDEX

类别 TYPE	代号 PART NO	页次 PAGE
公制外螺纹O型圈平面密封/可调向柱端重系列主支三通 METRIC MALE O-RING/METIRC MALE ADJUSTABLE STUD S-SERIES RUN TEE	AEEH-OG	14
公制外螺纹O型圈平面密封/可调向柱端重系列分支三通 METRIC MALE O-RING/METIRC MALE ADJUSTABLE STUD S-SERIES BRANCH TEE	AEHE-OG	14
90° 公制外螺纹O型圈平面密封过板接头 90° METRIC MALE O-RING BULKHEAD RUN TEE	AEE6E	15
公制外螺纹O型圈平面密封过板分支三通 METRIC MALE O-RING BULKHEAD BRANCH TEE	AE6EE	15
公制外螺纹24° 轻系列变径 METRIC MALE 24° L.T.REDUCERS	1C	16
公制外螺纹24° 轻系列 METRIC MALE 24° L.T.	1C	17
公制外螺纹24° 重系列 METRIC MALE 24° H.T.	1D	17
公制外螺纹24° 重系列变径 METRIC MALE 24° H.T. REDUCERS	1D	18
90° 公制外螺纹24° 轻系列 90° METRIC MALE 24° L.T.	1C9	19
90° 公制外螺纹24° 重系列 90° METRIC MALE 24° H.T.	1D9	19
公制内螺纹24° /公制外螺纹24° 轻系列 METRIC FEMALE 24° /METRIC MALE 24° L.T.	2C	20
公制内螺纹24° /公制外螺纹24° 重系列 METRIC FEMALE 24° /METRIC MALE 24° H.T.	2D	21
90° 公制内螺纹24° /公制外螺纹24° 轻系列 90° METRIC FEMALE 24° /METRIC MALE 24° L.T.	2C9	22
90° 公制内螺纹24° /公制外螺纹24° 重系列 90° METRIC FEMALE 24° /METRIC MALE 24° H.T.	2D9	22
公制内螺纹24° 轻系列 METRIC FEMALE 24° L.T.	3C	23
公制内螺纹24° 重系列 METRIC FEMALE 24° H.T.	3D	23
公制螺纹24° 轻系列堵头 METRIC MALE 24° L.T. PULG	4C	24
公制螺纹24° 重系列堵头 METRIC MALE 24° H.T. PLUG	4D	24
公制外螺纹24° 轻系列过板接头 METRIC MALE 24° L.T. BULKHEAD	6C	25
公制外螺纹24° 重系列过板接头 METRIC MALE 24° H.T. BULKHEAD	6D	25
90° 公制外螺纹24° 轻系列过板接头 90° METRIC MALE 24° L.T. BULKHEAD	6C9	26

# 目录 INDEX

类别 TYPE	代号 PART NO	页次 PAGE
90° 公制外螺纹24° 重系列过板接头 90° METRIC MALE 24° H.T. BULKHEAD	6D9	26
公制螺纹锁母 METRIC LOCK NUT	8C	27
公制内螺纹24° 轻系列堵头 METRIC FEMALE 24° L.T. PLUG	9C	28
公制内螺纹24° 重系列堵头 METRIC FEMALE 24° H.T. PLUG	9D	28
公制外螺纹24° 轻系列/布锥管外螺纹60° METRIC MALE 24° L.T./NPT MALE 60°	1CN	29
公制外螺纹24° 重系列/布锥管外螺纹60° METRIC MALE 24° H.T./NPT MALE 60°	1DN	30
90° 公制外螺纹24° 轻系列/布锥管外螺纹60° 90° METRIC MALE 24° L.T./NPT MALE 60°	1CN9	31
90° 公制外螺纹24° 重系列/布锥管外螺纹60° 90° METRIC MALE 24° H.T./NPT MALE 60°	1DN9	32
公制外螺纹24° 轻系列/英锥管外螺纹60° METRIC MALE 24° L.T./BSPT MALE 60°	1CT	33
公制外螺纹24° 重系列/英锥管外螺纹60° METRIC MALE 24° H.T./BSPT MALE 60°	1DT	34
90° 公制外螺纹24° 轻系列/英锥管外螺纹60° 90° METRIC MALE 24° L.T./BSPT MALE 60°	1CT9	35
90° 公制外螺纹24° /英锥管外螺纹60° 重系列 90° METRIC MALE 24° /BSPT MALE 60° H.T.	1DT9	36
公制外螺纹24° 轻系列/英管螺纹或60° 锥面组合垫密封 METRIC MALE 24° SEAL L.T./BSP MALEDOUBLE 60° SEAT BONDED SEAL	1CB	37
公制外螺纹24° 重系列/英管螺纹或60° 锥面或组合垫密封 METRIC MALE 24° SEALH.T./BSP MALEDOUBLE 60° SEAT BONDED SEAL	1DB	38
90° 公制外螺纹24° 轻系列/英管螺纹60° 锥面密封 90° METRIC MALE 24° L.T./BSP MALE 60° CONE	1CB9	39
90° 公制外螺纹24° 重系列/英管螺纹60° 锥面密封 90° METRIC MALE 24° H.T./BSP MALE BSP MALE 60° CONE	1DB9	40
公制外螺纹24° 轻系列/英管螺纹60° 内锥面或胶垫密封 METRIC MALE 24° L.T./BSP THREAD WITH CAPTIVE SEAL	1CB-WD	41
公制外螺纹24° 重系列/英管螺纹60° 内锥面胶垫密封 METRIC MALE 24° H.T./BSP THREAD WITH CAPTIVE SEAL	1DB-WD	42
公制外螺纹24° 轻系列/英管外螺纹O型圈密封 METRIC MALE 24° L.T./BSP MALE O-RING	1CG	43
公制外螺纹24° 重系列/英管外螺纹O型圈密封 METRIC MALE 24° H.T./BSP MALE O-RING	1DG	44
45° 英管螺纹24° 轻系列可调向柱端 45° BSP THREAD 24° L.T.ADJUSTABLE STUD.	1CG4-OG	45

# 目录 INDEX

类别 TYPE	代号 PART NO	页次 PAGE
45° 英管螺纹24° 重系列可调向柱端 45° BSP THREAD 24° H.T.ADJUSTABLE STUD.	1DG4-OG	45
90° 英管螺纹24° 轻系列可调向柱端 90° BSP THREAD 24° L.T.ADJUSTABLE STUD	1CG9-OG	46
90° 英管螺纹24° 重系列可调向柱端 90° BSP THREAD 24° H.T.ADJUSTABLE STUD.	1DG9-OG	46
公制外螺纹24° 轻系列/ 六角端面O型圈密封 METRIC MALE 24° L.T./METRIC MALE WITH O-RING	1CH	47
公制外螺纹24° 重系列/ 外螺纹六角端面O型圈密封 METRIC MALE 24° H.T./METRIC MALE WITH O-RING	1DH	48
45° 公制外螺纹24° 轻系列可调向柱端 45° METRIC MALE 24° L.T.ADJUSTABLE STUD	1CH4-OG	49
45° 公制外螺纹24° 重系列可调向柱端 45° METRIC MALE 24° H.T.ADJUSTABLE STUD	1DH4-OG	49
90° 公制外螺纹24° 轻系列可调向柱端 90° METRIC MALE 24° L.T.ADJUSTABLE STUD	1CH9-OG	50
90° 公制外螺纹24° 重系列可调向柱端 90° METRIC MALE 24° H.T.ADJUSTABLE STUD	1DH9-OG	50
公制外螺纹24° 轻系列/美制JIC74° 锥密封 METRIC MALE 24° L.T./JIC 74° CONE SEAL	1CJ	51
公制外螺纹24° 重系列/美制JIC74° 锥密封 METRIC MALE 24° H.T./JIC 74° CONE SEAL	1DJ	52
公制外螺纹24° 轻系列/60° 内锥面或组合垫密封 METRIC MALE 24° L.T./60° CONE BONDED SEAL	1CM	53
公制外螺纹24° 轻系列/60° 内锥面或胶垫密封 METRIC MALE 24° L.T./60° CONE CAPTIVE SEAL	1CM-WD	54
公制外螺纹24° 重系列/60° 内锥面或组合垫密封 METRIC MALE 24° H.T./60° CONE BONDED SEAL	1DM	55
公制外螺纹24° 重系列/60° 内锥面或胶垫密封 METRIC MALE 24° H.T./60° CONE CAPTIVE SEAL	1DM-WD	55
公制外螺纹24° 轻系列/ 美制外螺纹O型圈密封 METRIC MALE 24° L.T./SAE MALE O-RING	1CO	56
公制外螺纹24° 重系列/ 美制外螺纹O型圈密封 METRIC MALE 24° H.T./SAE MALE O-RING	1DO	57
90° 公制外螺纹24° 轻系列/美制外螺纹可调向柱端 90° METRIC 24° L.T./SAE MALE ADJUSTABLE STUD	1CO9-OG	58
90° 公制外螺纹24° 重系列/美制外螺纹可调向柱端 90° METRIC 24° H.T./SAE MALE ADJUSTABLE STUD	1DO9-OG	58
公制外螺纹24° 轻系列/焊接接头 METRIC MALE 24° L.T./WELD FITTINGS	1CW	59
公制外螺纹24° 重系列/焊接接头 METRIC MALE 24° H.T./WELD FITTINGS	1DW	59



# 目录 INDEX

类别 TYPE	代号 PART NO	页次 PAGE
公制螺纹24°轻系列/英管螺纹60°锥面组合垫密封 METRIC FEMALE 24° L.T./BSP MALEDOUBLE 60° SEAT BONDED SEAL	2BC-WD	60
公制螺纹24°重系列/英管螺纹60°锥面组合垫密封 METRIC FEMALE 24° H.T./BSP MALEDOUBLE 60° SEAT BONDED SEAL	2BD-WD	60
美制JIC 74°锥密封/公制内螺纹24°锥O型圈密封轻系列 JIC 74° CONE SEALING/METRIC FEMALE 24° CONE O-RING SEALING L.T.	2JC	61
美制JIC 74°锥密封/公制内螺纹24°锥O型圈密封重系列 JIC 74° CONE SEALING/METRIC FEMALE 24° CONE O-RING SEALING H.T.	2JD	62
公制螺纹24°轻系列锥O型圈/英管螺纹 O型圈密封 METRIC FEMALE 24° L.T.CONE O-RING/BSP MALEO-RING	2GC	63
公制螺纹24°重系列锥O型圈/英管螺纹 O型圈密封 METRIC FEMALE 24° H.T.CONE O-RING/BSP MALEO-RING	2GD	63
公制螺纹胶垫密封/公制内螺纹24°锥面O型圈密封轻系列 METRIC THREAD /METRIC FEMALE24° CONE O-RING SEAL L.T.	2MC-WD	64
公制螺纹胶垫密封/公制内螺纹24°锥面O型圈密封重系列 METRIC THREAD /METRIC FEMALE24° CONE O-RING SEAL H.T.	2MD-WD	64
公制螺纹24°轻系列/英管内螺纹 METRIC MALE 24° L.T./BSP FEMALE	5CB	65
公制螺纹24°重系列/英管内螺纹 METRIC MALE 24° H.T./BSP FEMALE	5DB	66
公制螺纹24°轻系列/公制内螺纹 METRIC MALE 24° L.T./METRIC FEMALE	5CM	67
公制螺纹24°重系列/公制内螺纹 METRIC MALE 24° H.T./METRIC FEMALE	5DM	67
公制外螺纹24°轻系列三通 METRIC MALE 24° L.T. TEE	AC	68
公制外螺纹24°重系列三通 METRIC MALE 24° H.T. TEE	AD	68
公制内螺纹24°/公制外螺纹24°轻系列三通 METRIC FEMALE 24° /METRIC MALE 24° L.T. TEE	BC	69
公制内螺纹24°/公制外螺纹24°重系列三通 METRIC FEMALE 24° /METRIC MALE 24° H.T. TEE	BD	69
公制外螺纹24°/公制内螺纹24°轻系列三通 METRIC MALE 24° /METRIC FEMALE 24° L.T. TEE	CC	70
公制外螺纹24°/公制内螺纹24°重系列三通 METRIC MALE 24° /METRIC FEMALE 24° H.T. TEE	CD	70
公制外螺纹24°轻系列四通 METRIC MALE 24° L.T. CROSS	XC	71
公制外螺纹24°重系列四通 METRIC MALE 24° H.T. CROSS	XD	71
公制外螺纹24°轻系列可调向柱端分支三通 METRIC MALE 24° L.T.ADJUSTABLE STUD BRADCH TEE	ACHC-OG	72

# 目录 INDEX

类别 TYPE	代号 PART NO	页次 PAGE
公制外螺纹24°重系列可调向柱端分支三通 METRIC MALE 24° H.T.ADJUSTABLE STUD BRADCH TEE	ADHD-OG	72
公制外螺纹24°轻系列可调向柱端主支三通 METRIC MALE 24° L.T.ADJUSTABLE STUD RUN TEE	ACCH-OG	73
公制外螺纹24°重系列可调向柱端主支三通 METRIC MALE 24° H.T.ADJUSTABLE STUD RUN TEE	ADDH-OG	73
公制外螺纹24°轻系列/英管可调向柱端主支三通 METRIC MALE 24° L.T./BSP MALE ADJUSTABLE STUD RUN TEE	ACCG-OG	74
公制外螺纹24°重系列/英管可调向柱端主支三通 METRIC MALE 24° H.T./BSP MALE ADJUSTABLE STUD RUN TEE	ADDG-OG	74
公制外螺纹24°轻系列/英管可调向柱端分支三通 METRIC MALE 24° L.T./BSP MALE ADJUSTABLE STUD BRANCH TEE	ACGC-OG	75
公制外螺纹24°重系列/英管可调向柱端分支三通 METRIC MALE 24° H.T./BSP MALE ADJUSTABLE STUD BRANCH TEE	ADGD-OG	75
公制24°轻系列/美制可调向柱端主支三通 METRIC MALE 24° L.T./SAE MALE ADJUSTABLE STUD RUN TEE	ACCO-OG	76
公制24°重系列/美制可调向柱端主支三通 METRIC MALE 24° H.T./SAE MALE ADJUSTABLE STUD RUN TEE	ADDO-OG	76
公制24°轻系列/美制可调向柱端分支三通 METRIC MALE 24° L.T./SAE MALE ADJUSTABLE STUD BRANCH TEE	ACOC-OG	77
公制24°重系列/美制可调向柱端分支三通 METRIC MALE 24° H.T./SAE MALE ADJUSTABLE STUD BRANCH TEE	ADOD-OG	77
公制螺纹24°轻系列/英管螺纹铰接接头 METRIC MALE 24° L.T./BSP BANJO	1CL-B	78
公制螺纹24°重系列/英管螺纹铰接接头 METRIC MALE 24° H.T./BSP BANJO	1DL-B	78
公制螺纹24°轻系列/公制螺纹铰接接头 METRIC MALE 24° L.T./METRIC BANJO	1CL	79
公制螺纹24°重系列/公制螺纹铰接接头 METRIC MALE 24° H.T./METRIC BANJO	1DL	79
英制铰接螺栓 BSP BOLT	720B	80
公制铰接螺栓 METRIC BOLT	700M	80
卡套螺母轻系列 RETAINING NUTS L.T.	NL	81
卡套螺母重系列 RETAINING NUTS H.T.	NS	81
卡套轻系列 CUTTING RING L.T.	RL	82
卡套重系列 CUTTING RING H.T.	RS	82

# 目录 INDEX

类别 TYPE	代号 PART NO	页次 PAGE
公制外螺纹74°外锥 METRIC MALE 74° CONE	1Q	83
公制外螺纹74°外锥堵头 METRIC MALE 74° CONE PLUG	4Q	84
公制外螺纹74°外锥过板接头 METRIC MALE 74° CONE BULKHEAD	6Q	85
90°公制外螺纹74°外锥过板接头 90° METRIC MALE 74° CONE BULKHEAD	6Q9	86
公制外螺纹74°外锥/布锥管外螺纹 METRIC MALE 74° CONE/NPT MALE	1QN	87
45°公制外螺纹74°外锥/布锥管外螺纹 45° METRIC MALE 74° CONE/NPT MALE	1QN4	88
90°公制外螺纹74°外锥/布锥管外螺纹 90° METRIC MALE 74° CONE/NPT MALE	1QN9	89
公制外螺纹74°外锥/英锥管外螺纹 METRIC MALE 74° CONE/BSPT MALE	1QT	90
90°公制外螺纹74°外锥/英锥管外螺纹 90° METRIC MALE 74° CONE/BSPT MALE	1QT9	91
公制外螺纹74°外锥/英管外螺纹60°内锥或六角端面组合垫密封 METRIC MALE 74° CONE/BSP MALE DOUBLE FOR 60° SEAT BONDED SEAL	1QB	92
公制74°外锥/英管外螺纹O型圈 METRIC 74° CONE/BSP MALE O-RING	1QG	93
90°公制74°外锥/英管外螺纹O型圈可调向柱端 90° METRIC 74° CONE/BSP MALE O-RING ADJUSTABLE STUD	1QG9-OG	93
公制74°外锥/公制外螺纹 METRIC 74° CONE/METRIC MALE	1QH	94
90°公制74°外锥/公制外螺纹可调向柱端 90° METRIC 74° CONE/METRIC MALE ADJUSTABLE STUD	1QH9-OG	94
公制外螺纹74°外锥/公制外螺纹60°内锥或六角端面组合垫密封 METRIC MALE 74° CONE/METRIC MALE DOUBLE FOR 60° SEAT BONDED SEAL	1QM	95
公制外螺纹74°外锥/SAE外螺纹O型圈 METRIC MALE74° CONE/SAE MALE O-RING	1QO	96
90°公制外螺纹74°外锥/SAE外螺纹O型圈 90° METRIC MALE74° CONE/SAE MALE O-RING ADJUSTABLE STUD	1QO9-OG	96
90°公制外螺纹74°外锥/公制内螺纹74°内锥 90° METRIC MALE 74° CONE/METRIC FEMALE 74° SEAT	2Q9	97
公制外螺纹74°外锥三通 METRIC MALE 74° CONE TEE	AQ	97
公制外螺纹74°外锥/可调向柱端分支三通 METRIC MALE74° CONE/ADJUSTABLE STUD BRANCH TEE	AQH-Q-OG	98
公制外螺纹74°外锥/可调向柱端主支三通 METRIC MALE74° CONE/ADJUSTABLE STUD RUN TEE	AQQH-OG	98

# 目录 INDEX

类别 TYPE	代号 PART NO	页次 PAGE
日本公制外螺纹60°外锥 JIS METRIC MALE60° CONE	1K	99
90°日本公制螺纹60°外锥 90° JIS METRIC MALE60° CONE	2K9	99
日本公制外螺纹60°外锥堵头 JIS METRIC MALE60° CONE PLUG	4K	100
日本公制内螺纹内锥60° JIS METRIC FEMALE 60° SEAT PLUG	9K	100
日本公制外螺纹60°外锥/布锥管外螺纹 JIS METRIC MALE 60° CONE/NPT MALE	1KN	101
日本公制外螺纹60°外锥/公制外螺纹60°密封或组合垫圈 JIS METRIC MALE60° CONE/METRIC MALE 60° CONE BONDED SEAL	1KM	101
日本公制外螺纹60°/英锥管外螺纹 JIS METRIC MALE60° CONE/BSPT MALE	1KT	102
日本公制外螺纹60°外锥/公制外螺纹重系列 JIS METRIC MALE60° CONE/METRIC MALE S-SERIES	1KH	102
90°日本公制外螺纹60°外锥/公制外螺纹可调向柱端 90° JIS METRIC MALE 60° CONE/METRIC ALE ADJUSTABLE STUD	1KH9-OG	103
日本公制外螺纹60°外锥/英管外螺纹O型圈 JIS METRIC MALE 60° CONE/BSP MALE O-RING	1KG	104
90°日本公制外螺纹60°/英管外螺纹O型圈可调向柱端 90° JIS METRIC MALE/BSP MALE O-RING ADJUSTABLE STUD	1KG9-OG	104
日本公制外螺纹60°外锥三通 JIS METRIC MALE60° CONE TEE	AK	105
日本公制外螺纹60°外锥/日本公制内螺纹60°内锥分支三通 JIS METRIC MALE60° CONE/JIS METRIC FEMALE 60° SEAT BRANCH TEE	BK	105
日本公制外螺纹/英管外螺纹O型圈可调向柱端主支三通 JIS METRIC MALE/BSP MALE O-RING RUN TEE ADJUSTABLE STUD	AKKG-OG	106
日本公制外螺纹60°外锥/公制外螺纹可调向柱端主支三通 JIS METRIC MALE 60° CONE/ADJUSTABLE STUD RUN TEE	AKKH-OG	107
日本公制外螺纹/英管外螺纹O型圈可调向柱端分支三通 JIS METRIC MALE/BSP MALE O-RING ADJUSTABLE STUD BRANCH TEE	AKGK-OG	107
日本公制外螺纹60°外锥/公制外螺纹可调向柱端分支三通 JIS METRIC MALE 60° CONE/ADJUSTABLE STUD BRANCHTEE	AKHK-OG	108
公制外螺纹74°内锥面 METRIC MALE 74° CONE SEAT	1V	109
公制外螺纹74°内锥面/英锥管外螺纹 METRIC MALE 74° CONE SEAT/BSPT MALE	1VT	109
日本英管外螺纹60°外锥 JIS GAS MALE 60° CONE	1S	110
日本英管外螺纹60°外锥堵头 JIS GAS MALE 60° CONE PLUG	4S	110

# 目录 INDEX

类别 TYPE	代号 PART NO	页次 PAGE
日本英管内螺纹60°内锥堵头 JIS GAS FEMALE 60°SEAT PLUG	9S	111
日本英管外螺纹60°外锥过板接头 JIS GAS MALE 60°CONE BULKHEAD	6S	111
日本英管外螺纹60°外锥/英锥管外螺纹 JIS GAS MALE 60°CONE/BSPT MALE	1ST	112
45°日本英管外螺纹60°外锥/英锥管外螺纹 45°JIS GAS MALE 60°CONE/BSPT MALE	1ST4	113
90°日本英管外螺纹60°外锥/英锥管外螺纹 90°JIS GAS MALE 60°CONE/BSPT MALE	1ST9	114
日本英管外螺纹60°外锥/布锥管外螺纹 JIS GAS MALE 60°CONE/NPT MALE	1SN	115
45°日本英管外螺纹60°外锥/布锥管外螺纹 45°JIS GAS MALE 60°CONE/NPT MALE	1SN4	116
90°日本英管外螺纹60°外锥/布锥管外螺纹 90°JIS GAS MALE 60°CONE/NPT MALE	1SN9	117
日本英管外螺纹60°外锥/英管外螺纹O型圈 JIS GAS MALE 60°CONE/BSP MALE O-RING	1SG	118
90°日本英管外螺纹60°外锥/英管外螺纹60°O型圈可调向柱端 90°JIS GAS MALE 60°CONE/BSP MALE O-RING ADJUSTABLE STUD	1SG9-OG	118
日本英管外螺纹60°外锥三通 JIS GAS FEMALE 60°SEAT TEE	AS	119
日本英管外螺纹60°外锥/日本英管内螺纹60°内锥分支三通 JIS GAS MALE 60°CONE/JIS GAS FEMALE 60°SEAT BRANCH TEE	BS	119
日本英管外螺纹60°外锥/日本英管内螺纹60°内锥主支三通 JIS GAS MALE 60°CONE/JIS GAS FEMALE 60°SEAT RUN TEE	CS	120
日本英管内螺纹60°内锥三通 JIS GAS FEMALE 60°SEAT TEE	DS	120
日本英管外螺纹60°外锥/英管外螺纹O型圈可调向柱端分支三通 JIS GAS MALE 60°CONE/BSP MALE O-RING ADJUSTABLE STUD BRANCH TEE	ASGS-OG	121
日本英管外螺纹60°外锥/英管外螺纹O型圈可调向柱端主支三通 JIS GAS MALE 60°CONE/BSP MALE O-RING ADJUSTABLE STUD END RUN TEE	ASSG-OG	121
英管外螺纹60°内锥或六角端面组合垫密封 BSP MALE DOUBLE FOR 60°SEAT BONDED SEAL	1B	122
45°英管外螺纹60°内锥 45°BSP MALE 60°SEAT	1B4	123
90°英管外螺纹60°内锥 90°BSP MALE 60°SEAT	1B9	124
英管外螺纹60°内锥或六角端面组合垫密封/英管内螺纹60°外锥 BSP MALE DOUBLE FOR 60°SEAT BONDED SEAL /BSP FEMALE 60°CONE	2B	125
45°英管外螺纹60°内锥/英管内螺纹60°外锥 45°BSP MALE 60°SEAT/BSP FEMALE 60°CONE	2B4	126

# 目录 INDEX

类别 TYPE	代号 PART NO	页次 PAGE
90° 英管外螺纹60° 内锥/ 英管内螺纹60° 外锥 90° BSP MALE 60° SEAT/BSP FEMALE 60° CONE	2B9	127
英管内螺纹60° 外锥 BSP FEMALE 60° CONE	3B	128
45° 英管内螺纹60° 外锥 45° BSP FEMALE 60° CONE	3B4	129
90° 英管内螺纹60° 外锥 90° BSP FEMALE 60° CONE	3B9	129
英管外螺纹60° 内锥或六角端面用组合垫密封堵头 BSP MALE DOUBLE FOR 60° SEAT OR BONDED SEAL PLUG	4B	130
英管内螺纹60° 外锥堵头 BSP FEMALE 60° CONE PLUG	9B	130
英管外螺纹60° 内锥过板接头 BSP MALE 60° SEAT BULKHEAD	6B	131
90° 英管外螺纹60° 内锥过板接头 90° BSP MALE 60° SEAT BULKHEAD	6B9	131
英管螺纹锁母 BSP LOCK NUT	8B	132
英管外螺纹60° 内锥或六角端面组合垫密封/ 英锥管外螺纹 BSP MALE DOUBLE FOR 60° SEAT BONDED SEAL/BSPT MALE	1BT	133
45° 英管外螺纹60° 内锥/ 英锥管外螺纹 45° BSP MALE 60° SEAT /BSPT MALE	1BT4	134
90° 英管外螺纹60° 内锥/ 英锥管外螺纹 90° BSP MALE 60° SEAT /BSPT MALE	1BT9	135
英管外螺纹60° 内锥六角或端面组合垫密封/ 布锥管外螺纹 BSP MALE DOUBLE FOR 60° SEAT BONDED SEAL/NPT MALE	1BN	136
45° 英管外螺纹60° 内锥/ 布锥管外螺纹 45° BSP MALE 60° SEAT /NPT MALE	1BN4	137
90° 英管外螺纹60° 内锥/ 布锥管外螺纹 90° BSP MALE 60° SEAT /NPT MALE	1BN9	138
英管外螺纹60° 内锥或六角端面组合垫密封/ 英锥管外螺纹O 型圈 BSP MALE DOUBLE FOR 60° SEAT BONDED SEAL/BSPT MALE O-RING	1BG	139
45° 英管外螺纹60° 内锥/ 英管外螺纹O型圈可调向柱端 45° BSP MALE 60° SEAT/BSP MALE O-RING ADJUSTABLE STUD END	1BG4-OG	140
90° 英管外螺纹60° 内锥/ 英管外螺纹O型圈可调向柱端 90° BSP MALE 60° SEAT/BSP MALE O-RING ADJUSTABLE STUD END	1BG9-OG	141
英管外螺纹60° 内锥或六角端面组合垫密封/ 公制外螺纹轻系列 BSP MALE DOUBLE FOR 60° SEAT BONDED SEAL/METRIC MALE L-SERIES	1BH	142
45° 英管外螺纹60° 内锥/ 公制外螺纹轻系列 45° BSP MALE 60° SEAT/METRIC MALE O-RING	1BH4-OG	143
90° 英管外螺纹60° 内锥/ 公制外螺纹轻系列 90° BSP MALE 60° SEAT/METRIC MALE O-RING	1BH9-OG	144

# 目录 INDEX

类别 TYPE	代号 PART NO	页次 PAGE
英管外螺纹60°内锥或六角端面组合垫密封/美制JIC外螺纹74°外锥 BSP MALE DOUBLE FOR 60° SEATBONDED SEAL/JIC MALE 74° CONE	1BJ	145
英管外螺纹60°内锥或六角端面组合垫密封/美制JIC外螺纹74°外锥 BSP MALE DOUBLE FOR 60° SEATBONDED SEAL/JIC MALE 74° CONE	1BJ	146
45°英管外螺纹60°内锥/美制JIC外螺纹74°外锥 45° BSP MALE 60° SEAT/JIC MALE 74° CONE	1BJ4	147
90°英管外螺纹60°内锥/美制JIC外螺纹74°外锥 90° BSP MALE 60° SEAT/JIC MALE 74° CONE	1BJ9	148
英管外螺纹60°内锥或六角端面组合垫密封/公制外螺纹60° 内锥或六角端面组合垫密封 BSP MALE 60° SEAT DOUBLE 60° SEAT BONDED SEAL /METRIC MALE DOUBLE 60° SEAT BONDED SEAL	1BM	149
英管外螺纹60°内锥或六角端面组合垫密封/美制SAE 外螺纹带O型圈轻系列 BSP MALE 60° SEAT BONDED SEAL/SAE O-RING BOSS L-SERIES	1BO	150
英管外螺纹60°内锥或六角端面组合垫密封/焊接管 BSP MALE 60° SEAT BONDED SEAL/BUTT-WELD TUBE	1BW	151
焊接管/英管内螺纹60°外锥 BUTT-WELD TUBE/BSP FEMALE 60° CONE	2WB	151
英管外螺纹60°内锥或六角端面组合垫密封/英管外螺纹胶垫密封 BSP MALE 60° SEAT BONDED SEAL/BSP MALE CAPTIVE SEAL	1B-WD	152
英管外螺纹60°内锥或六角端面组合垫密封/美制JIC内螺纹74°内锥 BSP MALE DOUBLE FOR 60° SEATBONDED SEAL/JIC FEMALE 74° SEAT	2BJ	153
英管外螺纹胶垫密封/美制JIC内螺纹74°内锥 BSP MALE CAPTIVE SEAL/JIC FEMALE 74° SEAT	2BJ-WD	154
英锥管外螺纹/英管内螺纹60°外锥 BSPT MALE/BSP FEMALE 60° CONE	2TB	155
45°英锥管外螺纹/英管内螺纹60°外锥 45° BSPT MALE/BSP FEMALE 60° CONE	2TB4	156
90°英锥管外螺纹/英管内螺纹60°外锥 90° BSPT MALE/BSP FEMALE 60° CONE	2TB9	156
布锥管外螺纹/英管内螺纹60°外锥 NPT MALE/BSP FEMALE 60° CONE	2NB	157
45°布锥管外螺纹/英管内螺纹60°外锥 45° NPT MALE/BSP FEMALE 60° CONE	2NB4	158
90°布锥管外螺纹/英管内螺纹60°外锥 90° NPT MALE/BSP FEMALE 60° CONE	2NB9	159
英管外螺纹胶垫密封内六角堵头 BSP MALE CAPTIVE SEAL HOLLOW HEX PLUG	4BN-WD	160
英管外螺纹胶垫密封堵头 BSP MALE CAPTIVE SEAL PLUG	4B-WD	160
英管外螺纹60°内锥或六角端面组合垫密封/英管内螺纹 BSP MALE DOUBLE FOR 60° SEATBONDED SEAL/BSP FEMALE	5B	161

# 目录 INDEX

类别 TYPE	代号 PART NO	页次 PAGE
90° 英管外螺纹60° 内锥/ 英管内螺纹 90° BSP MALE 60° SEAT/BSP FEMALE	5B9	162
英管外螺纹60° 内锥或六角端面组合垫密封/ 美制布锥管内螺纹 BSP MALE DOUBLE FOR 60° EATBONEDE SEAL/NPT FEMALE	5BN	163
英管外螺纹60° 内锥或六角端面组合垫密封/ 英锥管内螺纹 BSP MALE DOUBLE FOR 60° EATBONEDE SEAL/BSPT FEMALE	5BT	163
英管外螺纹胶垫密封/ 英管内螺纹 BSP MALE CAPTIVE SEAL/BSP FEMALE	5B-WD	164
英管外螺纹O型圈/ 英管内螺纹 BSP MALE O-RING/BSP FEMALE	5GB	165
英锥管内螺纹/英管内螺纹60° 外锥 BSPT FEMALE/BSP FEMALE 60° CONE	7TB	165
英管内螺纹 BSP FEMALE	7B	166
90° 英管内螺纹 90° BSP FEMALE	7B9	167
英管内螺纹三通 BSP FEMALE TEE	GB	167
英管外螺纹60° 内锥三通 BSP MALE 60° SEAT TEE	AB	168
英管外螺纹60° 内锥/ 英管内螺纹外锥分支三通 BSP MALE 60° SEAT/BSP FEMALE 60° CONE BRANCH TEE	BB	168
英管外螺纹60° 内锥/ 英管内螺纹外锥主支三通 BSP MALE 60° SEAT/BSP FEMALE 60° CONE RUN TEE	CB	169
英管内螺纹外锥三通 BSP FEMALE 60° CONE TEE	DB	169
英管内螺纹60° 外锥/ 英管外螺纹60° 内锥分支三通 BSP FEMALE 60° CONE/BSP MALE 60° BRANCH TEE	EB	170
英管内螺纹60° 外锥/ 英管外螺纹60° 内锥分支三通 BSP FEMALE 60° CONE/BSP MALE 60° BRANCH TEE	FB	170
英管外螺纹60° 内锥/ 英管外螺纹O型圈可调向柱端主支三通 BSP MALE 60° SEAT/BSP MALEO-RING ADJUSTABLE STUD END RUN TEE	ABBG-OG	171
英管外螺纹60° 内锥/ 英管外螺纹O型圈可调向柱端分支三通 BSP MALE 60° SEAT/BSP MALEO-RINGADJUSTABLE STUD END BRANCH TEE	ABGB-OG	171
英锥管外螺纹 BSPT MALE	1T	172
45° 英锥管外螺纹 45° BSPT MALE	1T4	173
90° 英锥管外螺纹 90° BSPT MALE	1T9	173
英锥管外螺纹堵头 BSPT MALE PLUG	4T	174



# 目录 INDEX

类别 TYPE	代号 PART NO	页次 PAGE
英锥管外螺纹内六角堵头 BSPT MALE HOLLOW HEX PLUG	4TN	174
英锥管外螺纹/ 英锥管内螺纹 BSPT MALE/BSPT FEMALE	5T	175
90° 英锥管外螺纹/ 英锥管内螺纹 90° BSPT MALE/BSPT FEMALE	5T9	176
英锥管内螺纹 BSPT FEMALE	7T	177
90° 英锥管内螺纹 90° BSPT FEMALE	7T9	178
英锥管内螺纹三通 BSPT FEMALE TEE	GT	178
英锥管内螺纹四通 BSPT FEMALE CROSS	ZT	179
英管外螺纹O型圈/ 英锥管内螺纹 BSP MALE O-RING/BSPT FEMALE	5GT	179
美制布锥管外螺纹 NPT MALE	1N	180
45° 美制布锥管外螺纹 45° NPT MALE	1N4	181
90° 美制布锥管外螺纹 90° NPT MALE	1N9	181
美制布锥管外螺纹内六角堵头 NPT MALE HOLLOW HEX PLUG	4NN	182
美制布锥管外螺纹堵头 NPT MALE PLUG	4N	182
美制布锥管外螺纹/ 布锥管内螺纹 NPT MALE/NPT FEMALE	5N	183
45° 美制布锥管外螺纹/ 布锥管内螺纹 45° NPT MALE/NPT FEMALE	5N4	184
90° 美制布锥管外螺纹/ 布锥管内螺纹 90° NPT MALE/NPT FEMALE	5N9	184
美制布锥管内螺纹 NPT FEMALE	7N	185
90° 美制布锥管内螺纹 90° NPT FEMALE	7N9	186
美制布锥管内螺纹堵头 NPT FEMALE PLUG	9N-CAP	186
美制SAE外螺纹带O型圈/ 美制布锥管外螺纹 NPT MALE/SAE O-RING BOSS	1NO	187
布锥管外螺纹/ 美制NPSM内螺纹60° 外锥 NPT MALE/NPSM FEMALE 60° CONE	2NU	188

# 目录 INDEX

类别 TYPE	代号 PART NO	页次 PAGE
45° 布锥管外螺纹/美制NPSM内螺纹60° 外锥 45° NPT MALE/NPSM FEMALE 60° CONE	2NU4	189
90° 布锥管外螺纹/美制NPSM内螺纹60° 外锥 90° NPT MALE/NPSM FEMALE 60° CONE	2NU9	190
美制外螺纹O型圈/ 美制布锥管内螺纹 BSP MALE O-RING/NPT FEMALE	5GN	191
公制外螺纹轻系列/ 美制布锥管内螺纹 METRIC MALE L-SERIES/NPT FEMALE	5HN	192
公制外螺纹组合垫圈/ 美制布锥管内螺纹 METRIC MALE WITH BONDED SEAL/NPT FEMALE	5MN	192
美制布锥管外螺纹/ 美制SAE内螺纹 NPT MALE/SAE FEMALE	5NO	193
美制SAE外螺纹O型圈轻系列/ 美制布锥管内螺纹 SAE O-RING BOSS L-SERIES/NPT FEMALE	5ON	194
英锥管外螺纹/ 美制布锥管内螺纹 BSPT MALE/NPT FEMALE	5TN	195
美制布锥管内螺纹四通 NPT FEMALE CROSS	ZN	195
布锥管内螺纹/ 美制NPSM内螺纹60° 外锥 NPT FEMALE/NPSM FEMALE 60° CONE	7NU	196
美制布锥管外螺纹三通 NPT MALE TEE	AN	197
布锥管内螺纹三通 NPT FEMALE TEE	GN	197
美制布锥管内螺纹/ 布锥管外螺纹分支三通 NPT FEMALE/NPT MALE BRANCH TEE	JN	198
美制布锥管内螺纹/ 布锥管外螺纹主支三通 NPT FEMALE/NPT MALE RUN TEE	HN	198
美制JIC外螺纹74° 外锥 JIC MALE 74° CONE	1J	199
45° 美制JIC外螺纹74° 外锥 45° JIC MALE 74° CONE	1J4	200
90° 美制JIC外螺纹74° 外锥 90° JIC MALE 74° CONE	1J9	200
90° 美制JIC外螺纹74° 外锥 90° JIC MALE 74° CONE	1J9	200
美制JIC外螺纹74° 外锥/JIC内螺纹74° 内锥 JIC MALE 74° CONE/JIC FEMALE 74° SEAT	2J	201
45° 美制JIC外螺纹74° 外锥/JIC内螺纹74° 内锥 45° JIC MALE 74° CONE/JIC FEMALE 74° SEAT	2J4	202
90° 美制JIC外螺纹74° 外锥/JIC内螺纹74° 内锥 90° JIC MALE 74° CONE/JIC FEMALE 74° SEAT	2J9	203

# 目录 INDEX

类别 TYPE	代号 PART NO	页次 PAGE
美制JIC内螺纹74°内锥 JIC FEMALE 74° SEAT	3J	204
45°美制JIC内螺纹74°内锥 45° JIC FEMALE 74° SEAT	3J4	204
90°美制JIC内螺纹74°内锥 90° JIC FEMALE 74° SEAT	3J9	205
美制JIC外螺纹74°外锥堵头 JIC MALE 74° CONE PLUG	4J	205
美制JIC外螺纹/美制JIC内螺纹 JIC MALE/JIC FEMALE	5J	206
美制JIC外螺纹74°外锥过板接头 JIC MALE 74° CONE BULKHEAD	6J	207
45°美制JIC外螺纹74°外锥过板接头 45° JIC MALE 74° CONE BULKHEAD	6J4	207
90°美制JIC外螺纹74°外锥过板接头 90° JIC MALE 74° CONE BULKHEAD	6J9	208
美制JIC锁母 JIC LOCK NUT	8J	208
美制JIC内螺纹74°内锥堵头 JIC FEMALE 74° SEAT PLUG	9J	209
JIC74°内螺纹堵头 JIC 74° FEMALE PLUG	9J-CAP	209
JIC外螺纹74°外锥/英锥管外螺纹 JIC MALE 74° CONE/BSPT MALE	1JT	210
45° JIC外螺纹74°外锥/英锥管外螺纹 45° JIC MALE 74° CONE/BSPT MALE	1JT4	211
90° JIC外螺纹74°外锥/英锥管外螺纹 90° JIC MALE 74° CONE/BSPT MALE	1JT9	212
JIC外螺纹74°外锥/布锥管外螺纹 JIC MALE 74° CONE/NPT MALE	1JN	213
45° JIC外螺纹74°外锥/布锥管外螺纹 45° JIC MALE 74° CONE/NPT MALE	1JN4	214
90° JIC外螺纹74°外锥/布锥管外螺纹 90° JIC MALE 74° CONE/NPT MALE	1JN9	215
90° JIC外螺纹74°外锥/加长布锥管外螺纹 90° JIC MALE 74° CONE/LONG NPT MALE	1JN9-L	216
90° JIC外螺纹74°外锥/特长布锥管外螺纹 90° JIC MALE 74° CONE/LONGGER NPT MALE	1JN9-LL	217
美制JIC外螺纹74°外锥/英管内螺纹60°外锥 JIC MALE 74° CONE/BSP FEMALE 60° CONE	2JB	218
美制JIC外螺纹74°外锥/英管外螺纹O型圈 JIC MALE 74° CONE/BSP MALE O-RING	1JG	219

# 目录 INDEX

类别 TYPE	代号 PART NO	页次 PAGE
45° 美制JIC外螺纹74° 外锥/英管外螺纹O型圈 45° JIC MALE 74° CONE/BSP MALE O-RING	1JG4-OG	220
90° 美制JIC外螺纹74° 外锥/英管外螺纹O型圈 90° JIC MALE 74° CONE/BSP MALE O-RING	1JG9-OG	221
美制JIC外螺纹74° 外锥/ORFS外螺纹 JIC MALE 74° CONE/ORFS MALE	1JF	222
JIC外螺纹74° 外锥/公制外螺纹O型圈密封 JIC MALE 74° CONE/ METRIC MALE END O-RING	1JH	223
45° 美制JIC外螺纹74° 外锥/公制外螺纹可调向柱端 45° JIC MALE 74° CONE/METRIC MALEADJUSTABLE STUD END	1JH4-OG	224
90° 美制JIC外螺纹74° 外锥/公制外螺纹可调向柱端 90° JIC MALE 74° CONE/METRIC MALEADJUSTABLE STUD END	1JH9-OG	225
JIC外螺纹74° 外锥/公制外螺纹60° 内锥或六角端面组合垫密封 JIC MALE 74° CONE/METRIC MALE DOUBLEUSE FOR 60° SEAT OR BONDED SEAL	1JM	226
JIC外螺纹74° 外锥/公制外螺纹胶垫密封 JIC MALE 74° CONE/METRIC MALE CAPTIVE SEAL	1JM-WD	227
美制JIC外螺纹74° 外锥/SAE外螺纹带O型圈 JIC MALE 74° CONE/SAE O-RING BOSS	1JO	228
美制JIC外螺纹74° 外锥/SAE外螺纹带O型圈 JIC MALE 74° CONE/SAE O-RING BOSS	1JO	229
加长美制JIC外螺纹74° 外锥/SAE外螺纹带O型圈 LONG JIC MALE 74° CONE/SAE O-RING BOSS	1JO-L	229
45° JIC外螺纹74° 外锥/SAE外螺纹带O型圈 45° JIC MALE 74° CONE/SAE O-RING BOSS	1JO4-OG	230
90° JIC外螺纹74° 外锥/SAE外螺纹带O型圈 90° JIC MALE 74° CONE/SAE O-RING BOSS	1JO9-OG	231
90° 美制JIC外螺纹74° 外锥/加长SAE外螺纹带O型圈 90° JIC MALE 74° CONE/LONG SAE O-RING BOSS	1JO9-OG/L	232
英管外螺纹胶垫密封/JIC外螺纹74° 外锥 BSP MALE CAPTIVE SEAL/JIC MALE 74° CONE	1BJ-WD	233
英锥管外螺纹/JIC内螺纹74° 内锥 BSPT MALE/JIC FEMALE 74° SEAT	2TJ	234
布锥管外螺纹/JIC内螺纹74° 内锥 NPT MALE/JIC FEMALE 74° SEAT	2NJ	235
英管外螺纹O型圈/JIC内螺纹74° 锥面 BSP MALE O-RING/JIC FEMALE 74° CONE	2GJ	236
美制SAE外螺纹带O型圈/JIC内螺纹74° 内锥 SAE O-RING BOSS/JIC FEMALE 74° SEAT	2OJ	237
焊接管/美制JIC内螺纹74° 内锥 BUTT-WELD TUBE/JIC FEMALE 74° SEAT	2WJ	237
美制JIC外螺纹74° 外锥/英管内螺纹 JIC MALE 74° CONE/BSP FEMALE	5JB	238

# 目录 INDEX

类别 TYPE	代号 PART NO	页次 PAGE
美制JIC外螺纹74°外锥/英锥管内螺纹 JIC MALE 74° CONE/BSPT FEMALE	5JT	239
美制JIC外螺纹74°外锥/布锥管内螺纹 JIC MALE 74° CONE/NPT FEMALE	5JN	240
90°美制JIC外螺纹74°外锥/布锥管内螺纹 90° JIC MALE 74° CONE/NPT FEMALE	5JN9	241
美制NPT外螺纹/美制JIC外螺纹外锥过板接头 NPT MALE/JIC MALE 74° CONE BULKHEAD	6NJ	242
布锥管内螺纹/JIC内螺纹74°内锥 NPT FEMALE/JIC FEMALE 74° SEAT	7NJ	242
美制JIC外螺纹74°外锥三通 JIC MALE 74° CONE TEE	AJ	243
美制JIC外螺纹74°外锥/美制JIC内螺纹74°内锥分支三通 JIC MALE 74° CONE/JIC FEMALE BRANCH TEE	BJ	243
美制JIC外螺纹74°外锥/美制JIC内螺纹74°内锥主支三通 JIC MALE 74° CONE/JIC FEMALE 74° SEAT RUN TEE	CJ	244
美制JIC内螺纹74°内锥三通 JIC FEMALE 74° SEAT TEE	DJ	244
美制JIC内螺纹74°内锥/美制JIC外螺纹74°外锥分支三通 JIC FEMALE 74° SEAT/JIC MALE 74° CONE BRANCH TEE	EJ	245
美制JIC内螺纹74°内锥/美制JIC外螺纹74°外锥分支三通 JIC FEMALE 74° SEAT/JIC MALE 74° CONE BRANCH TEE	FJ	245
美制JIC外螺纹74°外锥/布锥管外螺纹分支三通 JIC MALE 74° CONE/NPT MALE BRANCH TEE	AJNJ	246
美制JIC外螺纹74°外锥/布锥管外螺纹主支三通 JIC MALE 74° CONE/NPT MALE RUN TEE	AJJN	247
美制JIC外螺纹74°外锥过板接头主支三通 JIC MALE 74° CONE BULKHEAD RUN TEE	AJJ6J	248
美制JIC外螺纹74°外锥过板接头分支三通 JIC MALE 74° CONE BULKHEAD BRANCH TEE	AJ6JJ	248
美制JIC外螺纹74°外锥/布锥管内螺纹分支三通 JIC MALE 74° CONE/NPT FEMALE BRANCH TEE	KJNJ	249
美制JIC外螺纹74°外锥/布锥管内螺纹主支三通 JIC MALE 74° CONE/NPT FEMALE RUN TEE	LJJN	250
美制JIC外螺纹74°外锥/SAE外螺纹带O型圈分支三通 JIC MALE 74° CONE/SAE O-RING BOSS BRANCH TEE	AJOJ-OG	251
美制JIC外螺纹74°外锥/SAE外螺纹带O型圈主支三通 JIC MALE 74° CONE/SAE O-RING BOSS RUN TEE	AJJO-OG	252
JIC外螺纹74°外锥/英管外螺纹O型圈分支三通 JIC MALE 74° CONE/BSP MALE O-RING BRANCH TEE	AJGJ-OG	253
JIC外螺纹74°外锥/英管外螺纹O型圈主支三通 JIC MALE 74° CONE/BSP MALE O-RING RUN TEE	AJJG-OG	253

## 目录 INDEX

类别 TYPE	代号 PART NO	页次 PAGE
美制JIC外螺纹74°外锥/公制外螺纹可调向柱端主支三通 JIC MALE 74° CONE/METRIC MALE ADJUSTABLE STUD END	AJJH-OG	254
JIC公制管衬套 JIC METRIC SLEEVE	NB500	255
JIC英制管衬套 JIC INCH SLEEVE	NB300	256
美制JIC扩口管接头螺母 JIC FLARE TUBE END NUT	00TSUM-NB	256
美制ORFS外螺纹O型圈平面密封 ORFS MALE O-RING	1F	257
45°美制ORFS外螺纹O型圈平面密封 45° ORFS MALE O-RING	1F4	258
90°美制ORFS外螺纹O型圈平面密封 90° ORFS MALE O-RING	1F9	258
美制ORFS外螺纹O型圈平面密封/ ORFS内螺纹 ORFS MALE O-RING/ORFS FEMALE	2F	259
45°美制ORFS外螺纹O型圈平面密封/ ORFS内螺纹 45° ORFS MALE O-RING/ORFS FEMALE	2F4	260
90°美制ORFS外螺纹O型圈平面密封/ ORFS内螺纹 90° ORFS MALE O-RING/ORFS FEMALE	2F9	260
美制ORFS内螺纹 ORFS FEMALE	3F	261
美制ORFS外螺纹O型圈平面密封堵头 ORFS MALE O-RING PLUG	4F	261
美制ORFS外螺纹O型圈平面密封过板接头 ORFS MALE O-RING BULKHEAD	6F	262
45°美制ORFS外螺纹O型圈平面密封过板接头 45° ORFS MALE O-RING BULKHEAD	6F4	262
90°美制ORFS外螺纹O型圈平面密封过板接头 90° ORFS MALE O-RING BULKHEAD	6F9	263
美制ORFS锁母 ORFS LOCK NUT	8F	264
美制ORFS内螺纹堵头 ORFS FEMALE PLUG	9F	264
美制ORFS外螺纹O型圈平面密封/ 布锥管外螺纹 ORFS MALE O-RING/NPT MALE	1FN	265
45°美制ORFS外螺纹O型圈平面密封/ 布锥管外螺纹 45° ORFS MALE O-RING/NPT MALE	1FN4	266
90°美制ORFS外螺纹O型圈平面密封/ 布锥管外螺纹 90° ORFS MALE O-RING/NPT MALE	1FN9	267
美制ORFS外螺纹O型圈平面密封/ 公制外螺纹 ORFS MALE O-RING/METRIC MALE O-RING	1FH	268

# 目录 INDEX

类别 TYPE	代号 PART NO	页次 PAGE
45° 美制ORFS外螺纹O型圈平面密封/ 公制外螺纹可调向柱端 45° ORFS MALE O-RING/ METRIC MALE ADJUSTABLE STUD END	1FH4-OG	269
90° 美制ORFS外螺纹O型圈平面密封/ 公制外螺纹可调向柱端 90° ORFS MALE O-RING/ METRIC MALE ADJUSTABLE STUD END	1FH9-OG	269
美制ORFS外螺纹O型圈平面密封/ 美制外螺纹带O型圈重系列 ORFS MALE O-RING/SAE O-RING BOSS S-SERIES	1FO	270
45° 美制ORFS外螺纹O型圈平面密封/ 美制外螺纹带O型圈重系列 45° ORFS MALE O-RING/SAE O-RING BOSS S-SERIES	1FO4-OG	271
90° 美制ORFS外螺纹O型圈平面密封/ 美制外螺纹带O型圈重系列 90° ORFS MALE O-RING/SAE O-RING BOSS S-SERIES	1FO9-OG	272
美制ORFS外螺纹O型圈平面密封/ 英管外螺纹O型圈 ORFS MALE O-RING/BSP MALE O-RING	1FG	273
45° 美制ORFS外螺纹O型圈平面密封/ 英管外螺纹O型圈 45° ORFS MALE O-RING/BSP MALE O-RING	1FG4-OG	274
90° 美制ORFS外螺纹O型圈平面密封/ 英管外螺纹O型圈 90° ORFS MALE O-RING/BSP MALE O-RING	1FG9-OG	275
美制SAE外螺纹O型圈重系列/ ORFS 内螺纹 SAE O-RING BOSS S-SERIES/ORFS FEMALE	2OF	276
美制ORFS外螺纹O型圈平面密封过板接头主支三通 ORFS MALE O-RING BULKHEAD RUN TEE	AFF6F	277
美制ORFS外螺纹O型圈平面密封过板接头分支三通 ORFS MALE O-RING BULKHEAD BRANCH TEE	AF6FF	277
美制ORFS外螺纹O型圈平面密封/ 英管外螺纹O型圈主支三通 ORFS MALE O-RING/BSP MALE O-RING RUN TEE	AFFG-OG	278
美制ORFS外螺纹O型圈平面密封/ 英管外螺纹O型圈分支三通 ORFS MALE O-RING/BSP MALE O-RING RUN TEE	AFGF-OG	278
美制ORFS外螺纹O型圈平面密封/ 美制SAE外螺纹带O型圈分支三通 ORFS MALE O-RING/SAE O-RING BOSS BRANCH TEE	AFOF-OG	279
美制ORFS外螺纹O型圈平面密封/ 美制SAE外螺纹带O型圈主支三通 ORFS MALE O-RING/SAE O-RING BOSS RUN TEE	AFFO-OG	280
美制ORFS外螺纹O型圈平面密封/ 公制外螺纹可调向柱端主支三通 ORFS MALE O-RING/ METRIC MALE ADJUSTABLE STUD END RUN TEE	AFFH-OG	281
美制ORFS外螺纹O型圈平面密封/ 公制外螺纹可调向柱端分支三通 ORFS MALE O-RING/ METRIC MALE ADJUSTABLE STUD END BRANCH TEE	AFHF-OG	281
英管外螺纹O型圈 BSP MALE O-RING	1G	282
英管外螺纹O型圈堵头 BSP MALE O-RING PLUG	4G	282
英管外螺纹O型圈/ 英锥管外螺纹 BSP MALE O-RING/BSPT MALE	1GT	283
公制外螺纹轻系列内六角堵头 METRIC MALE L-SERIES HOLLOW HEX PLUG	4HN	283

# 目录 INDEX

类别 TYPE	代号 PART NO	页次 PAGE
公制外螺纹轻系列 METRIC MALE L-SERIES	1H	284
公制外螺纹轻系列堵头 METRIC MALE L-SERIES PLUG	4H	284
公制外螺纹60°内锥或六角端面组合垫密封 METRIC MALE DOUBLE FOR 60° CONE SEAT BONDED SEAL	1M	285
公制外螺纹60°内锥或六角端面组合垫密封堵头 METRIC MALE DOUBLE FOR 60° CONE SEAT BONDED SEAL PLUG	4M	286
公制外螺纹胶垫密封内六角堵头 METRIC MALE CAPTIVE SEAL HOLLOW HEX PLUG	4MN-WD	286
美制SAE外螺纹带O型圈 SAE O-RING BOSS	1O	287
美制SAE外螺纹带O型圈/英锥管外螺纹 SAE O-RING BOSS/BSPT MALE	1OT	287
SAE外螺纹带O型圈/美制NPSM内螺纹60°外锥 SAE O-RING BOSS /NPSM FEMALE 60° CONE	2OU	288
美制SAE外螺纹带O型圈堵头 SAE O-RING BOSS PLUG	4O	289
美制SAE外螺纹带O型圈内六角堵头 SAE O-RING BOSS HOLLOW HEX PLUG	4ON	289
美制SAE外螺纹90°外锥 SAE MALE 90° CONE	1P	290
美制SAE外螺纹90°外锥堵头 SAE MALE 90° CONE PLUG	4P	290
轻系列对开法兰夹 L-SERIES SPLIT FLANGE CLAMPS	FL	291
重系列对开法兰夹 S-SERIES SPLIT FLANGE CLAMPS	FS	291
轻系列整体法兰夹 L-SERIES WHOLE FLANGE CLAMPS	FL-W	292
重系列整体法兰夹 S-SERIES WHOLE FLANGE CLAMPS	FS-W	292
公制螺纹卡套式/轻系列法兰 METRIC MALE BITE TYPE/L-SERIES FLANGE	1CFL	293
公制螺纹卡套式/轻系列法兰 METRIC MALE BITE TYPE/L-SERIES FLANGE	1DFL	293
90°公制螺纹卡套式/轻系列法兰 90° METRIC MALE BITE TYPE/L-SERIES FLANGE	1CFL9	294
90°公制螺纹卡套式/轻系列法兰 90° METRIC MALE BITE TYPE/L-SERIES FLANGE	1DFL9	294
公制螺纹卡套式/重系列法兰 METRIC MALE BITE TYPE/S-SERIES FLANGE	1DFS	295



# 目录 INDEX

类别 TYPE	代号 PART NO	页次 PAGE
90° 公制螺纹卡套式/重系列法兰 90° METRIC MALE BITE TYPE/S-SERIES FLANGE	1DFS9	295
美制ORFS外螺纹O型圈平面密封/轻系列法兰 ORFS MALE O-RING/L-SERIES FLANGE	1FFL	296
90° 美制ORFS外螺纹O型圈平面密封/轻系列法兰 90° ORFS MALE O-RING/L-SERIES FLANGE	1FFL9	296
美制ORFS外螺纹O型圈平面密封/重系列法兰 ORFS MALE O-RING/S-SERIES FLANGE	1FFS	296
90° 美制ORFS外螺纹O型圈平面密封/重系列法兰 90° ORFS MALE O-RING/S-SERIES FLANGE	1FFS9	297
美制JIC外螺纹74° 外锥/轻系列法兰 JIC MALE 74° CONE/L-SERIES FLANGE	1JFL	297
45° 美制JIC外螺纹74° 外锥/轻系列法兰 45° JIC MALE 74° CONE/L-SERIES FLANGE	1JFL4	298
90° 美制JIC外螺纹74° 外锥/轻系列法兰 90° JIC MALE 74° CONE/L-SERIES FLANGE	1JFL9	299
美制JIC外螺纹74° 外锥/重系列法兰 JIC MALE 74° CONE/S-SERIES FLANGE	1JFS	300
45° 美制JIC外螺纹74° 外锥/重系列法兰 45° JIC MALE 74° CONE/S-SERIES FLANGE	1JFS4	301
90° 美制JIC外螺纹74° 外锥/重系列法兰 90° JIC MALE 74° CONE/S-SERIES FLANGE	1JFS9	302
轻系列法兰/焊接管 L-SERIES FLANGE/BUTT-WELD TUBE	1FLW	303
重系列法兰/焊接管 S-SERIES FLANGE/BUTT-WELD TUBE	1FSW	304
轻系列法兰堵头 L-SERIES FLANGE PLUG	4FL	305
重系列法兰堵头 S-SERIES FLANGE PLUG	4FS	305
轻系列平面法兰堵头 L-SERIES FLANGE PLUG	4FL-M	306
重系列平面法兰堵头 S-SERIES FLANGE PLUG	4FS-M	306

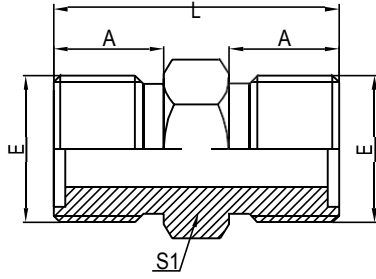

# 1E

公制外螺纹O型圈平面密封  
METRIC MALE O-RING

代号 PART NO.	螺纹 THREADS				尺寸 DIMENSIONS				
	E				A		S1		L
1E-12	M12x1.5				11		14		28
1E-14	M14x1.5				11		17		28
1E-16	M16x1.5				11		17		28
1E-18	M18x1.5				11		19		28
1E-22	M22x1.5				12		24		32
1E-27	M27x1.5				13		30		35
1E-30	M30x1.5				14		32		38
1E-36	M36x2				16		36		43
1E-39	M39x2				18		41		48
1E-45	M45x2				20		46		53
1E-52	M52x2				22		55		59
1E-60	M60x2				24		65		65
1E-64	M64x2				28		70		73

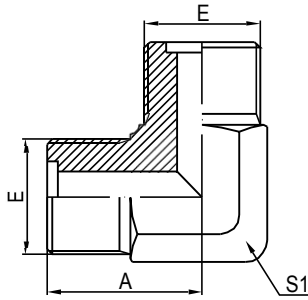

# 1E9

90° 公制外螺纹O型圈平面密封  
90° METRIC MALE O-RING

代号 PART NO.	螺纹 THREADE			尺寸 DIMENSIONS				
	E			A		S1		
1E9-12	M12x1.5			25		11		
1E9-14	M14x1.5			27		14		
1E9-16	M16x1.5			29		17		
1E9-18	M18x1.5			32		19		
1E9-22	M22x1.5			37		22		
1E9-27	M27x1.5			41		27		
1E9-30	M30x1.5			49		33		
1E9-36	M36x2			47		33		
1E9-39	M39x2			57		44		
1E9-45	M45x2			55		44		
1E9-52	M52x2			59		55		

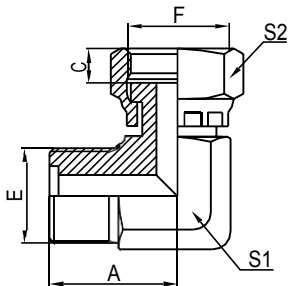

# 2E9

90° 公制螺纹O型圈平面密封  
90° METRIC MALE O-RING

代号 PART NO.	螺纹 THREADE		尺寸 DIMENSIONS				
	E	F	A	C	S1	S2	
2E9-14	M14x1.5	M14x1.5	29	9	14	19	
2E9-16	M16x1.5	M16x1.5	30	9.5	17	22	
2E9-18	M18x1.5	M18x1.5	33	9.5	19	24	
2E9-22	M22x1.5	M22x1.5	37	10	22	27	
2E9-27	M27x1.5	M27x1.5	41	10.5	27	32	
2E9-30	M30x1.5	M30x1.5	49	11.5	33	36	
2E9-36	M36x2	M36x2	47	13.5	33	41	
2E9-39	M39x2	M39x2	57	13.5	44	46	
2E9-45	M45x2	M45x2	55	15.5	44	55	
2E9-52	M52x2	M52x2	59	17.5	55	60	

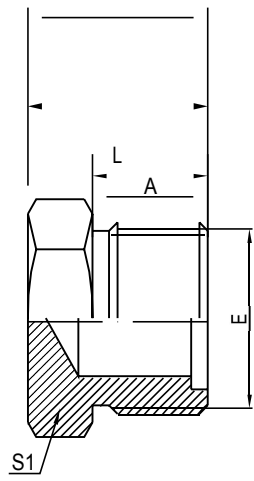

# 4E

公制外螺纹O型圈平面密封堵头  
METRIC MALE O-RING PLUG

代号 PART NO.	螺纹 THREADE				尺寸 DIMENSIONS				
	E				A		S1		L
4E-12	M12x1.5				11		14		17
4E-14	M14x1.5				11		17		17
4E-16	M16x1.5				11		17		17
4E-18	M18x1.5				11		19		17
4E-22	M22x1.5				12		24		20
4E-27	M27x1.5				13		30		22
4E-30	M30x1.5				14		32		24
4E-36	M36x2				16		41		28
4E-39	M39x2				18		41		30
4E-45	M45x2				20		46		33
4E-52	M52x2				22		55		37
4E-60	M60x2				24		65		41
4E-64	M64x2				28		70		45

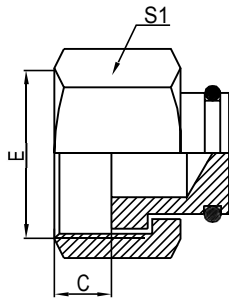

# 9E

公制内螺纹平面堵头  
METRIC FEMALE FLAT FACE PLUG

代号 PART NO.	螺纹 THREADE				尺寸 DIMENSIONS				
	E				C		S1		
9E-12	M12x1.5				8		14		
9E-14	M14x1.5				8		17		
9E-16	M16x1.5				8		19		
9E-18	M18x1.5				8.5		22		
9E-22	M22x1.5				10		27		
9E-27	M27x1.5				10.5		32		
9E-30	M30x1.5				11		36		
9E-36	M36x2				13		41		
9E-39	M39x2				13		46		
9E-45	M45x2				15		55		
9E-52	M52x2				17		60		

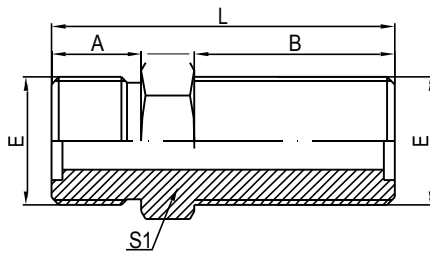

# 6E

公制外螺纹O型圈平面密封过板接头  
METRIC MALE O-RING BULKHEAD

代号 PART NO.	螺纹 THREADE				尺寸 DIMENSIONS				
	E				A	B	S1		L
6E-12	M12x1.5				11	31.5	14		48.5
6E-14	M14x1.5				11	32.5	17		49.5
6E-16	M16x1.5				11	32.5	17		49.5
6E-18	M18x1.5				11	33	19		50
6E-22	M22x1.5				12	35.5	24		55
6E-27	M27x1.5				13	37	30		59
6E-30	M30x1.5				14	38	32		62
6E-36	M36x2				16	42	41		70
6E-39	M39x2				18	44	41		74
6E-45	M45x2				20	46	46		79
6E-52	M52x2				22	49	55		86

如需带锁母订货,则请在代号后加"LN" 如6E-30LN

In case if you are interested to order the adapter with lock nut, please insert suffix "LN" after our part NO., for example 6E-30LN.

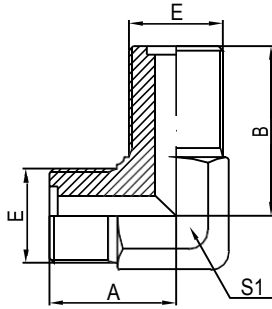

# 6E9

90° 公制外螺纹O型圈平面密封过板接头  
90° METRIC MALE O-RING BULKHEAD

代号 PART NO.	螺纹 THREADE		O型圈(外径X线径)		尺寸 DIMENSIONS				
	E		E端		A	B	S1		
6E9-12	M12x1.5		8x1.9		25	44.5	11		
6E9-14	M14x1.5		10x1.9		27	46.5	14		
6E9-16	M16x1.5		11x1.9		29	48	17		
6E9-18	M18x1.5		13x1.9		32	50	19		
6E9-22	M22x1.5		16x2.4		37	54	22		
6E9-27	M27x1.5		18x2.4		41	58.5	27		
6E9-30	M30x1.5		24x2.4		49	61.5	33		
6E9-36	M36x2		30x3.1		47	71	33		
6E9-39	M39x2		32x3.1		57	76	44		
6E9-45	M45x2		38x3.1		55	81	44		
6E9-52	M52x2		40x3.1		59	86	55		

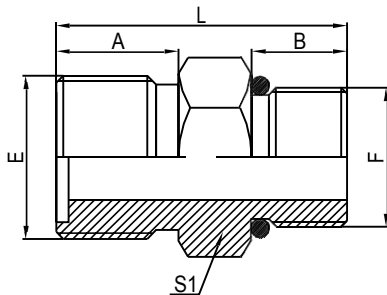

# 1EH

公制外螺纹O型圈平面密封  
公制外螺纹重系列  
METRIC MALE O-RING

代号 PART NO.	螺纹 THREADE		尺寸 DIMENSIONS					
	E	F	A	B	S1	L		
1EH-12-10	M12x1.5	M10x1	11	11	14	28		
1EH-14-12	M14x1.5	M12x1.5	11	11	17	28		
1EH-16-14	M16x1.5	M14x1.5	11	11	19	28		
1EH-18-16	M18x1.5	M16x1.5	11	11	22	29		
1EH-22-18	M22x1.5	M18x1.5	12	11	24	31		
1EH-27-22	M27x1.5	M22x1.5	13	12	30	34		
1EH-30-27	M30x1.5	M27x1.5	14	13	32	37		

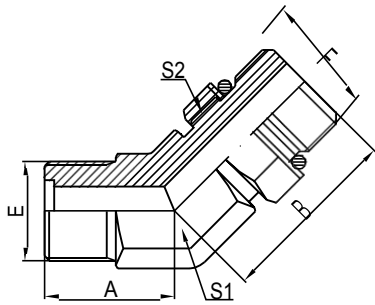

# 1EH4-OG

45° 公制外螺纹O型圈平面密封/  
可调向柱端重系列45°  
METRIC MALE O-RING/  
ADJUSTABLE STUD

代号 PART NO.	螺纹 THREADE		尺寸 DIMENSIONS				
	E	F	A	B	S1	S2	
1EH4-12-100G	M12x1.5	M10x1	20	25.5	11	14	
1EH4-14-120G	M14x1.5	M12x1.5	22	30	14	17	
1EH4-16-140G	M16x1.5	M14x1.5	22	30.5	17	19	
1EH4-18-160G	M18x1.5	M16x1.5	24	34	19	22	
1EH4-22-180G	M22x1.5	M18x1.5	27	38	22	24	
1EH4-27-220G	M27x1.5	M22x1.5	33	40.5	27	27	
1EH4-30-270G	M30x1.5	M27x1.5	33	48	27	32	
1EH4-36-330G	M36x2	M33x2	37	49.5	33	41	
1EH4-39-330G	M39x2	M33x2	41	52	44	41	
1EH4-45-420G	M45x2	M42x2	41	54	44	50	
1EH4-52-480G	M52x2	M48x2	47	58.5	53	55	

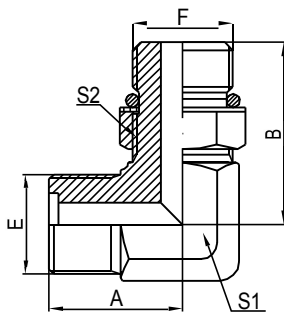

# 1EH9-OG

90° 公制外螺纹O型圈平面密封/  
可调向柱端重系列90°  
METRIC MALE O-RING/  
ADJUSTABLE STUD

代号 PART NO.	螺纹 THREADE		尺寸 DIMENSIONS				
	E	F	A	B	S1	S2	
1EH9-12-10	M12x1.5	M10x1	25	28.5	11	14	
1EH9-14-12	M14x1.5	M12x1.5	29	33.2	14	17	
1EH9-16-14	M16x1.5	M14x1.5	30	36	17	19	
1EH9-18-16	M18x1.5	M16x1.5	33	39	19	22	
1EH9-22-18	M22x1.5	M18x1.5	37	44	22	24	
1EH9-27-22	M27x1.5	M22x1.5	41	48	27	32	
1EH9-30-27	M30x1.5	M27x1.5	41	57	27	41	
1EH9-36-33	M36x2	M33x2	49	60.5	33	41	
1EH9-39-33	M39x2	M33x2	57	64	44	44	
1EH9-45-42	M45x2	M42x2	57	67.5	44	50	
1EH9-52-48	M52x2	M48x2	59	73.5	55	55	

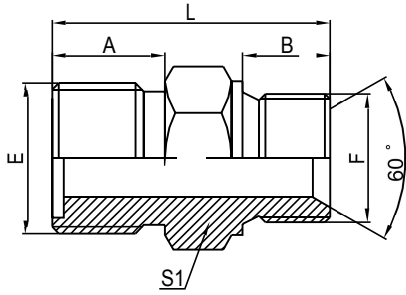

# 1EM

公制外螺纹O型圈平面密封/  
60° 内锥六角端面组合垫圈  
METRIC MALE O-RING/ 60°  
SEAT BONDED SEAL

代号 PART NO.	螺纹 THREADS		尺寸 DIMENSIONS				
	E	F	A	B	S1	L	
1EM-14-12	M14x1.5	M12x1.5	11	10	17	28	
1EM-14	M14x1.5	M14x1.5	11	11	19	28	
1EM-22-16	M22x1.5	M16x1.5	11	12	22	30	
1EM-22-18	M22x1.5	M18x1.5	11	12	24	31	
1EM-22	M22x1.5	M22x1.5	12	14	27	35	

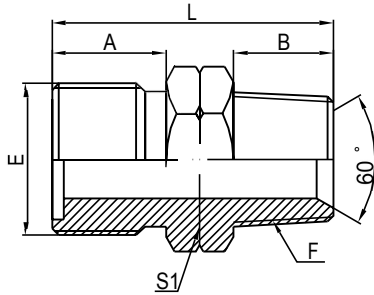

# 1EN

公制外螺纹O型圈/ 布锥管外螺纹  
METRIC MALE O-RING/NPT MALE

代号 PART NO.	螺纹 THREADS		尺寸 DIMENSIONS				
	E	F	A	B	S1	L	
1EN-14-04	M14x1.5	Z1/4"	11	14	17	31	
1EN-14-06	M14x1.5	Z3/8"	11	14	19	31	
1EN-16-04	M16x1.5	Z1/4"	11	14	17	31	
1EN-16-08	M16x1.5	Z1/2"	11	19	24	38	
1EN-18-06	M18x1.5	Z3/8"	11	14	19	31	
1EN-22-08	M22x1.5	Z1/2"	12	19	24	39	
1EN-24-08	M24x1.5	Z1/2"	13	19	30	41	
1EN-27-12	M27x1.5	Z3/4"	13	19.5	32	42.5	
1EN-30-12	M30x1.5	Z3/4"	14	19.5	32	43.5	
1EN-36-16	M36x2	Z1"	16	24	41	52	
1EN-39-16	M39x2	Z1"	18	24	41	54	
1EN-45-20	M45x2	Z1.1/4"	20	25	46	58	
1EN-52-20	M52x2	Z1.1/4"	22	25	55	62	
1EN-60-24	M60x2	Z1.1/2"					



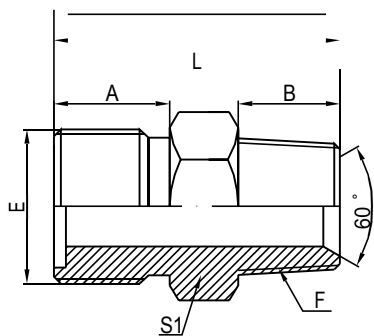

# 1ET

公制外螺纹O型圈/ 英锥管外螺纹  
METRIC MALE O-RING/BSPT MALE

代号 PART NO.	螺纹 THREADE		尺寸 DIMENSIONS				
	E	F	A	B	S1	L	
1ET-14-04	M14x1.5	ZG1/4"	11	14	17	31	
1ET-14-06	M14x1.5	ZG3/8"	11	14	19	31	
1ET-16-04	M16x1.5	ZG1/4"	11	14	17	31	
1ET-16-08	M16x1.5	ZG1/2"	11	19	24	38	
1ET-18-06	M18x1.5	ZG3/8"	11	14	19	31	
1ET-22-08	M22x1.5	ZG1/2"	12	19	24	39	
1ET-27-08	M24x1.5	ZG1/2"	13	19	27	41	
1ET-27-12	M27x1.5	ZG3/4"	13	19.5	32	42.5	
1ET-30-12	M30x1.5	ZG3/4"	14	19.5	32	43.5	
1ET-36-16	M36x2	ZG1"	16	24	41	52	
1ET-39-16	M39x2	ZG1"	18	24	41	54	
1ET-45-20	M45x2	ZG1.1/4"	20	25	46	58	
1ET-52-20	M52x2	ZG1.1/4"	22	25	55	62	
1ET-60-24	M60x2	ZG1.1/2"	24	25	70	66	

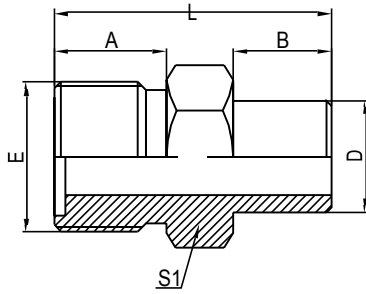

# 1EW

公制外螺纹O型圈平面密封/ 焊接管  
METRIC MALE O-RING/BUTT-WELD TUBE

代号 PART NO.	螺纹 THREADS				尺寸 DIMENSIONS				
	E				A	B	D	S1	L
1EW-12-06	M12x1.5				11	8	6	14	25
1EW-14-08	M14x1.5				11	8	8	17	25
1EW-16-10	M16x1.5				11	8	10	17	25
1EW-18-12	M18x1.5				11	12	12	19	29
1EW-22-14	M22x1.5				12	12	14	24	32
1EW-27-18	M27x1.5				13	12	18	30	34
1EW-30-22	M30x1.5				14	14	22	32	38
1EW-36-28	M36x2				16	16	28	41	44
1EW-39-30	M39x2				18	16	30	41	46
1EW-45-38	M45x2				20	18	38	46	51
1EW-52-42	M52x2				22	18	42	55	55

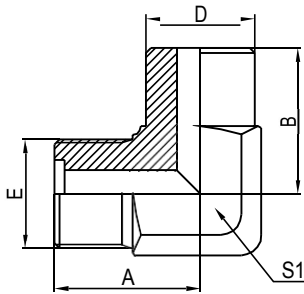

# 1EW9

90° 公制外螺纹O型圈平面密封/ 焊接管  
90° METRIC MALE O-RING/  
BUTT-WELD TUBE

代号 PART NO.	螺纹 THREADS				尺寸 DIMENSIONS				
	E				A	B	D	S1	
1EW9-12-06	M12x1.5				25	16.5	6	11	
1EW9-14-08	M14x1.5				29	17.5	8	14	
1EW9-16-10	M16x1.5				30	19.5	10	17	
1EW9-18-12	M18x1.5				33	25	12	19	
1EW9-22-14	M22x1.5				37	27	14	22	
1EW9-27-18	M27x1.5				41	29.5	18	27	
1EW9-30-22	M30x1.5				41	33.5	22	27	
1EW9-36-28	M36x2				47	39	28	33	
1EW9-39-30	M39x2				57	43	30	44	
1EW9-45-38	M45x2				57	47.5	38	44	
1EW9-52-42	M52x2				59	50	42	55	

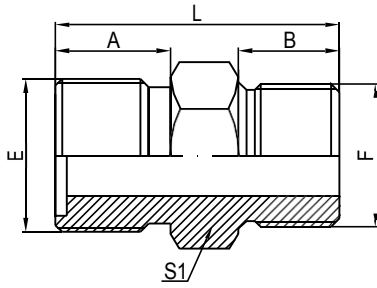

# 1EZ

公制外螺纹O型圈平面密封/  
英管螺纹组合垫密封METRIC  
MALE O-RING/  
BSP MALE

代号 PART NO.	螺纹 THREADE		尺寸 DIMENSIONS				
	E	F	A	B	S1	L	
1EZ-14-04	M14x1.5	G1/4"X19	11	12	19	29	
1EZ-16-04	M16x1.5	G1/4"X19	11	12	19	29	
1EZ-16-06	M16x1.5	G3/8"X19	11	12	22	30	
1EZ-18-06	M18x1.5	G3/8"X19	11	12	22	30	
1EZ-18-08	M18x1.5	G1/2"X14	11	14	27	34	
1EZ-22-08	M22x1.5	G1/2"X14	12	14	27	35	
1EZ-27-08	M27x1.5	G1/2"X14	13	14	27	36	
1EZ-27-12	M27x1.5	G3/4"X14	13	16	32	39	
1EZ-30-12	M30x1.5	G3/4"X14	14	16	32	40	
1EZ-30-16	M30x1.5	G1"X11	14	18	41	44	
1EZ-36-16	M36x2	G1"X11	16	18	41	46	

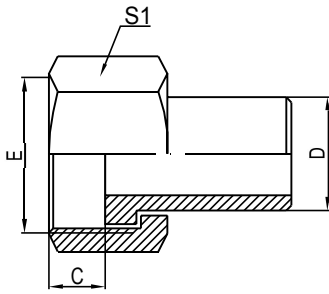

# 2WE

焊接管/ 公制内螺纹O型圈平面密封  
 BUTT-WELD TUBE/METRIC FEMALE O-RING

代号 PART NO.	螺纹 THREADE		管子直径 TUBE O.D.	尺寸 DIMENSIONS				
	E			C	D	S1		
2WE-06-12	M12x1.5		6	8	6	14		
2WE-08-14	M14x1.5		8	8	8	17		
2WE-10-16	M16x1.5		10	8	10	19		
2WE-12-18	M18x1.5		12	8.5	12	22		
2WE-14-22	M22x1.5		14	10	14	27		
2WE-18-27	M27x1.5		18	10.5	18	32		
2WE-22-30	M30x1.5		22	11	22	36		
2WE-28-36	M36x2		28	13	28	41		
2WE-30-39	M39x2		30	13	30	46		
2WE-38-52	M52x2		38	17	38	60		
2WE-42-52	M52x2		42	17	42	60		
2WE-50-60	M60x2		50	20	50	70		
2WE-52-64	M64x2		52	23	52	75		

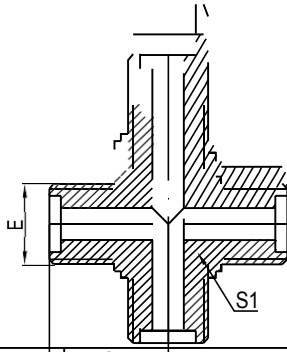

# XE

公制外螺纹O型圈平面密封四通接头  
METRIC MALE O-RING CROSS

代号 PART NO.	螺纹 THREADE		尺寸 DIMENSIONS			
	E		A	S1		
XE-14	M14x1.5		22.5	14		
XE-16	M16x1.5		24	17		
XE-18	M18x1.5		26	19		
XE-22	M22x1.5		29	22		
XE-27	M27x1.5		32.5	27		
XE-30	M30x1.5		35.5	30		
XE-36	M36x2		42	33		
XE-39	M39x2		47.5	41		
XE-45	M45x2		52.5	46		
XE-52	M52x2		57	55		

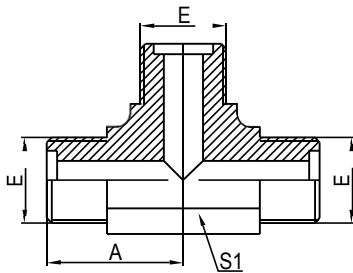

# AE

公制外螺纹O型圈平面密封三通接头  
METRIC MALE O-RING TEE

代号 PART NO.	螺纹 THREADE		尺寸 DIMENSIONS			
	E		A	S1		
AE-12	M12x1.5		25	11		
AE-14	M14x1.5		27	14		
AE-16	M16x1.5		29	17		
AE-18	M18x1.5		31	19		
AE-22	M22x1.5		34	22		
AE-27	M27x1.5		40	27		
AE-30	M30x1.5		40	27		
AE-36	M36x2		46	33		
AE-39	M39x2		57	44		

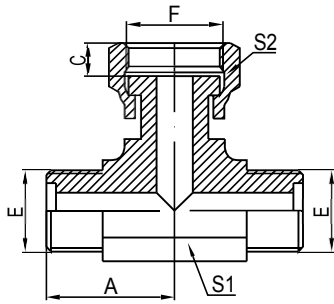

# BE

公制外螺纹O型圈/公制内  
 螺纹平面密封三通接头  
 METRIC MALE O-RING  
 /METRIC FEMALE TEE

代号 PART NO.	螺纹 THREADE		尺寸 DIMENSIONS				
	E	F	A	C	S1	S2	
BE-12	M12x1.5	M12x1.5	25	8	11	17	
BE-14	M14x1.5	M14x1.5	27	9	14	19	
BE-16	M16x1.5	M16x1.5	29	9.5	17	22	
BE-18	M18x1.5	M18x1.5	31	9.5	19	24	
BE-22	M22x1.5	M22x1.5	34	10	22	27	
BE-27	M27x1.5	M27x1.5	40	10.5	27	32	
BE-30	M30x1.5	M30x1.5	40	11.5	27	36	
BE-36	M36x2	M36x2	46	13.5	33	41	
BE-39	M39x2	M39x2	57	13.5	44	46	

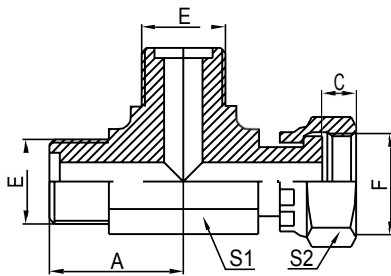

# CE

公制外螺纹O型圈/公制内  
 螺纹平面密封三通接头  
 METRIC MALE O-RING  
 /METRIC FEMALE TEE

代号 PART NO.	螺纹 THREADE		尺寸 DIMENSIONS				
	E	F	A	C	S1	S2	
CE-12	M12x1.5	M12x1.5	25	8	11	17	
CE-14	M14x1.5	M14x1.5	27	9	14	19	
CE-16	M16x1.5	M16x1.5	29	9.5	17	22	
CE-18	M18x1.5	M18x1.5	31	9.5	19	24	
CE-22	M22x1.5	M22x1.5	34	10	22	27	
CE-27	M27x1.5	M27x1.5	40	10.5	27	32	
CE-30	M30x1.5	M30x1.5	40	11.5	27	36	
CE-36	M36x2	M36x2	46	13.5	33	41	
CE-39	M39x2	M39x2	57	13.5	44	46	

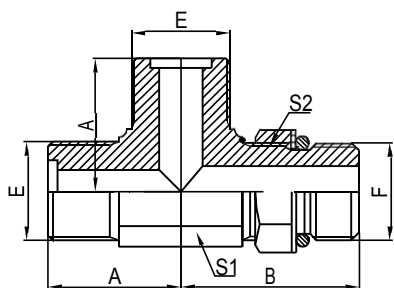

# AEEH-OG

公制外螺纹O型圈平面密封/  
公制外螺纹可调向柱端重系列主支三通  
METRIC MALE O-RING/  
METIRC MALE ADJUSTABLE STUD  
S-SERIES RUN TEE

代号 PART NO.	螺纹 THREADS		尺寸 DIMENSIONS				
	E	F	A	B	S1	S2	
AEEH-12-12-10OG	M12x1.5	M10x1	25	28.5	11	14	
AEEH-14-14-12OG	M14x1.5	M12x1.5	27	33.2	14	17	
AEEH-16-16-14OG	M16x1.5	M14x1.5	29	36	17	19	
AEEH-18-18-16OG	M18x1.5	M16x1.5	31	39	19	22	
AEEH-22-22-18OG	M22x1.5	M18x1.5	34	44	22	24	
AEEH-27-27-22OG	M27x1.5	M22x1.5	40	48	27	27	
AEEH-30-30-27OG	M30x1.5	M27x1.5	40	57	27	32	
AEEH-36-36-33OG	M36x2	M33x2	46	60.5	33	41	
AEEH-39-39-33OG	M39x2	M33x2	57	64	44	41	

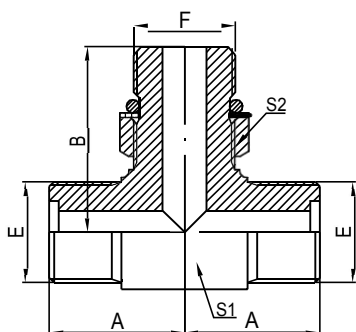

# AEHE-OG

公制外螺纹O型圈平面密封/  
公制外螺纹可调向柱端重系列分支三通  
METRIC MALE O-RING/  
METIRC MALE ADJUSTABLE STUD  
S-SERIES BRANCH TEE

代号 PART NO.	螺纹 THREADS		尺寸 DIMENSIONS				
	E	F	A	B	S1	S2	
AEHE-12-10-12OG	M12x1.5	M10x1	25	28.5	11	14	
AEHE-14-12-14OG	M14x1.5	M12x1.5	27	33.2	14	17	
AEHE-16-14-16OG	M16x1.5	M14x1.5	29	36	17	19	
AEHE-18-16-18OG	M18x1.5	M16x1.5	31	39	19	22	
AEHE-22-18-22OG	M22x1.5	M18x1.5	34	44	22	24	
AEHE-27-22-27OG	M27x1.5	M22x1.5	40	48	27	27	
AEHE-30-27-30OG	M30x1.5	M27x1.5	40	57	27	32	
AEHE-36-33-36OG	M36x2	M33x2	46	60.5	33	41	
AEHE-39-33-39OG	M39x2	M33x2	57	64	44	41	

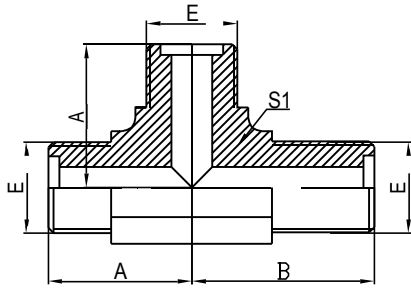

# AEE6E

90° 公制外螺纹O型圈平面密封过板接头  
90° METRIC MALE O-RING BULKHEAD RUN TEE

代号 PART NO.	螺纹 THREADE				尺寸 DIMENSIONS				
	E				A	B	S1		
AEE6E-12	M12x1.5				25	44.5	11		
AEE6E-14	M14x1.5				27	46.5	14		
AEE6E-16	M16x1.5				29	48	17		
AEE6E-18	M18x1.5				31	50	19		
AEE6E-22	M22x1.5				34	54	22		
AEE6E-27	M27x1.5				40	58.5	27		
AEE6E-30	M30x1.5				40	61.5	27		
AEE6E-36	M36x2				46	71	33		
AEE6E-39	M39x2				57	76	44		

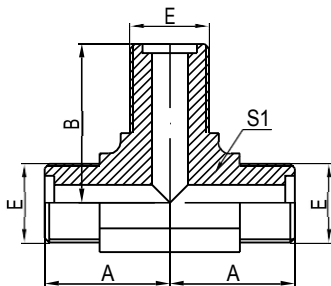

# AE6EE

公制外螺纹O型圈平面密封过板分支三通  
METRIC MALE O-RING BULKHEAD  
BRANCH TEE

代号 PART NO.	螺纹 THREADE				尺寸 DIMENSIONS				
	E				A	B	S1		
AE6EE-12	M12x1.5				25	44.5	11		
AE6EE-14	M14x1.5				27	46.5	14		
AE6EE-16	M16x1.5				29	48	17		
AE6EE-18	M18x1.5				31	50	19		
AE6EE-22	M22x1.5				34	54	22		
AE6EE-27	M27x1.5				40	58.5	27		
AE6EE-30	M30x1.5				40	61.5	27		
AE6EE-36	M36x2				46	71	33		
AE6EE-39	M39x2				57	76	44		



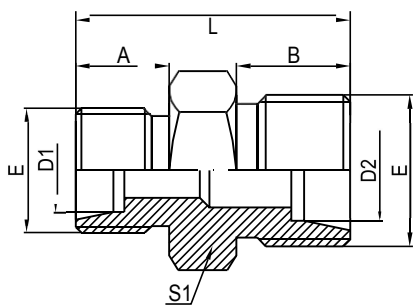

# 1C

公制外螺纹24°轻系列变径  
METRIC MALE 24° L.T. REDUCERS

代号 PART NO.	螺纹 THREADE		管子外径 TUBE O.D.		尺寸 DIMENSIONS				
	E		D1	D2	A	B	S1		L
1C-12-14	M12x1.5	M14x1.5	6	8	10	10	14		26
1C-12-16	M12x1.5	M16x1.5	6	10	10	11	17		27
1C-12-18	M12x1.5	M18x1.5	6	12	10	11	19		27
1C-14-16	M14x1.5	M16x1.5	8	10	11	11	17		28
1C-14-18	M14x1.5	M18x1.5	8	12	11	11	19		28
1C-16-18	M16x1.5	M18x1.5	10	12	11	11	19		28
1C-16-22	M16x1.5	M22x1.5	10	15	11	12	24		30
1C-16-26	M16x1.5	M26x1.5	10	18	11	12	27		33
1C-18-22	M18x1.5	M22x1.5	12	15	11.5	12	24		31
1C-18-26	M18x1.5	M26x1.5	12	18	11.5	12	27		32
1C-18-30	M18x1.5	M30x2	12	22	11.5	14	32		35.5
1C-22-26	M22x1.5	M26x1.5	15	18	12.5	12	27		33
1C-22-30	M22x1.5	M30x2	15	22	12.5	14	32		36.5
1C-26-30	M26x1.5	M30x2	18	22	12	14	32		37
1C-26-36	M26x1.5	M36x2	18	28	12	14	36		37
1C-30-36	M30x2	M36x2	22	28	14	14	36		39
1C-30-45	M30x2	M45x2	22	35	14	16	46		43
1C-33-45	M33x2	M45x2	25	35	16	16	46		45

备注:如需带卡套及卡套螺母整套订货,则请在代号后加"RN",如"1C-22-26RN"

Remark:In case if you are interested to order the adapter in complete set with cutting ring and nut,it is necessary to insert suffix"RN" arter our part NO.,for example 1C-22-26RN.

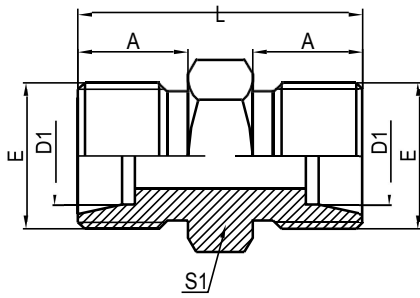

# 1C

公制外螺纹24°轻系列  
METRIC MALE 24° L.T.

代号 PART NO.	螺纹 THREADE		管子外径 TUBE O.D.		尺寸 DIMENSIONS				
	E		D1		A		S1		L
1C-12	M12x1.5		6		10		12		26
1C-14	M14x1.5		8		11		14		28
1C-16	M16x1.5		10		11		17		28
1C-18	M18x1.5		12		11.5		19		29
1C-22	M22x1.5		15		12.5		24		33
1C-26	M26x1.5		18		12		27		34
1C-30	M30x2		22		14		32		39
1C-36	M36x2		28		16		36		43
1C-45	M45x2		35		16		46		45
1C-52	M52x2		42		16		55		49

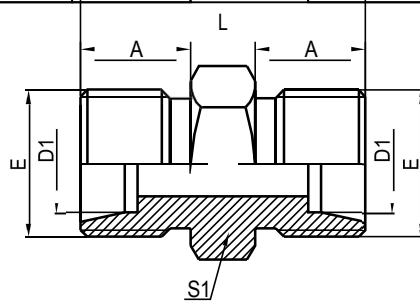

# 1D

公制外螺纹24°重系列  
METRIC MALE 24° H.T.

代号 PART NO.	螺纹 THREADE		管子外径 TUBE O.D.		尺寸 DIMENSIONS				
	E		D1		A		S1		L
1D-14	M14x1.5		6		12		14		30
1D-16	M16x1.5		8		12		17		30
1D-18	M18x1.5		10		12		19		30
1D-20	M20x1.5		12		12		22		31
1D-22	M22x1.5		14		14		24		36
1D-24	M24x1.5		16		14		27		38
1D-30	M30x2		20		16		32		43
1D-36	M36x2		25		18		36		47
1D-42	M42x2		30		20		46		52
1D-52	M52x2		38		22		55		61

备注:如需带卡套及卡套螺母整套订货,则请在代号后加"RN",如"1D-22RN" (同上)

Remark:In case if you are interested to order the adapter in complete set with cutting ring and nut,it is necessary to insert suffix"RN" arter our part NO.,for example 1D-22RN. (the same with above)

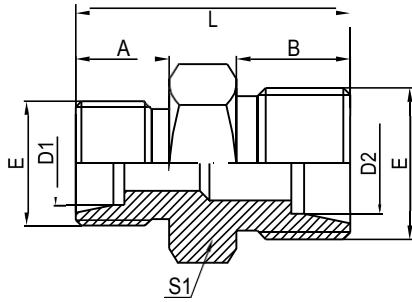

# 1D

公制外螺纹24°重系列变径  
METRIC MALE 24° H.T. REDUCERS

代号 PART NO.	螺纹 THREADE		管子外径 TUBE O.D.		尺寸 DIMENSIONS				
	E		D1	D2	A	B	S1		L
1D-14-16	M14x1.5	M16x1.5	6	8	12	12	17		30
1D-14-18	M14x1.5	M18x1.5	6	10	12	12	19		30
1D-14-20	M14x1.5	M20x1.5	6	12	12	12	22		32
1D-16-18	M16x1.5	M18x1.5	8	10	12	12	19		30
1D-16-20	M16x1.5	M20x1.5	8	12	12	12	22		32
1D-18-20	M18x1.5	M20x1.5	10	12	12	12	22		32
1D-18-22	M18x1.5	M22x1.5	10	14	12	14	24		34
1D-18-30	M18x1.5	M30x2	10	20	12	16	32		39
1D-20-22	M20x1.5	M22x1.5	12	14	12	14	24		34
1D-20-24	M20x1.5	M24x1.5	12	16	12	14	27		36
1D-20-30	M20x1.5	M30x2	12	20	12	16	32		39
1D-22-24	M22x1.5	M24x1.5	14	16	14	14	27		38
1D-24-30	M24x1.5	M30x2	16	20	14	16	32		41
1D-24-36	M24x1.5	M36x2	16	25	14	18	36		43
1D-30-36	M30x2	M36x2	20	25	16	18	36		45
1D-30-42	M30x2	M42x2	20	30	16	20	46		48
1D-36-42	M36x2	M42x2	25	30	18	20	46		50
1D-42-52	M42x2	M52x2	30	38	20	22	55		59

备注:如需带卡套及卡套螺母整套订货,则请在代号后加"RN",如"1D-22-24RN"

Remark: In case if you are interested to order the adapter in complete set with cutting ring and nut, it is necessary to insert suffix "RN" arter our part NO., for example 1D-22-24RN.

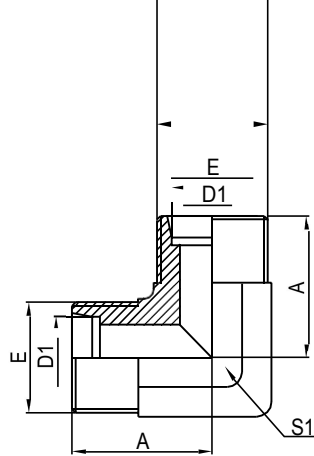

# 1C9

90° 公制外螺纹24° 轻系列  
90° METRIC MALE 24° L.T.

代号 PART NO.	螺纹 THREADE		管子外径 TUBE O.D.		尺寸 DIMENSIONS				
	E		D1		A		S1		
1C9-12	M12x1.5		6		25		11		
1C9-14	M14x1.5		8		29		14		
1C9-16	M16x1.5		10		30		17		
1C9-18	M18x1.5		12		33		19		
1C9-22	M22x1.5		15		37		22		
1C9-26	M26x1.5		18		41		27		
1C9-30	M30x2		25		41		27		
1C9-36	M36x2		28		46		33		
1C9-45	M45x2		35		55		44		
1C9-52	M52x2		42		59		55		

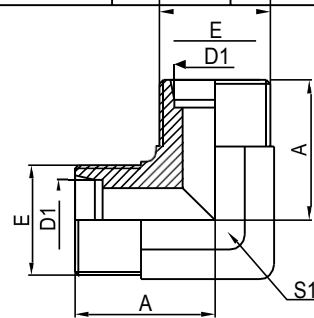

# 1D9

90° 公制外螺纹24° 重系列  
90° METRIC MALE 24° H.T.

代号 PART NO.	螺纹 THREADE		管子外径 TUBE O.D.		尺寸 DIMENSIONS				
	E		D1		A		S1		
1D9-14	M14x1.5		6		29		14		
1D9-16	M16x1.5		8		30		17		
1D9-18	M18x1.5		10		33		19		
1D9-20	M20x1.5		12		37		22		
1D9-22	M22x1.5		14		37		22		
1D9-24	M24x1.5		16		33		24		
1D9-30	M30x2		20		41		27		
1D9-42	M42x2		30		57		44		
1D9-52	M52x2		38		59		50		

备注:如需带卡套及卡套螺母整套订货,则请在代号后加"RN",如"1D9-22RN" (同上)  
Remark:In case if you are interested to order the adapter in complete set with cutting ring and nut, it is necessary to insert suffix"RN" arter our part NO., for example 1D9-22RN.(the same with above)

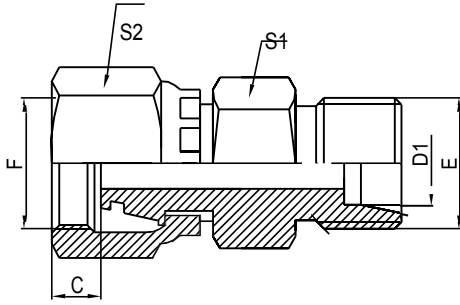

# 2C

公制内螺纹24° / 公制外螺纹24° 轻系列  
METRIC FEMALE 24° / METRIC MALE 24° L.T.

代号 PART NO.	螺纹 THREADE		管子外径 TUBE O.D.		尺寸 DIMENSIONS				
	E	F	D1		C		S1	S2	
2C-12	M12x1.5	M12x1.5	6		2		12	17	
2C-12-14	M12x1.5	M14x1.5	6		3.5		14	19	
2C-12-16	M12x1.5	M16x1.5	6		3.5		14	22	
2C-14	M14x1.5	M14x1.5	8		3.5		14	19	
2C-14-16	M14x1.5	M16x1.5	8		3.5		14	22	
2C-14-18	M14x1.5	M18x1.5	8		3.5		17	24	
2C-16	M16x1.5	M16x1.5	10		3.5		17	22	
2C-16-18	M16x1.5	M18x1.5	10		3.5		17	24	
2C-16-22	M16x1.5	M22x1.5	10		3		22	27	
2C-18	M18x1.5	M18x1.5	12		3.5		17	24	
2C-18-22	M18x1.5	M22x1.5	12		3		22	27	
2C-12-26	M12x1.5	M26x1.5	6		3.5		24	32	
2C-22-26	M22x1.5	M26x1.5	15		3.5		24	32	
2C-26	M26x1.5	M26x1.5	18		3.5		24	32	
2C-26-30	M26x1.5	M30x2	18		4.5		30	36	
2C-26-36	M26x1.5	M36x2	18		4.5		36	41	
2C-30	M30x2	M30x2	22		4.5		30	36	
2C-30-36	M30x2	M36x2	22		4.5		36	41	
2C-30-45	M30x2	M45x2	22		5.5		46	55	
2C-36-45	M36x2	M45x2	28		5.5		46	55	
2C-45	M45x2	M45x2	35		5.5		46	55	
2C-45-52	M45x2	M52x2	35		6.5		55	60	
2C-52	M52x2	M52x2	42		6.5		55	60	

备注: 如需带卡套及卡套螺母整套订货, 则请在代号后加"RN", 如"2C-22-26RN"

Remark: In case if you are interested to order the adapter in complete set with cutting ring and nut, it is necessary to insert suffix "RN" after our part NO., for example 2C-22-26RN.

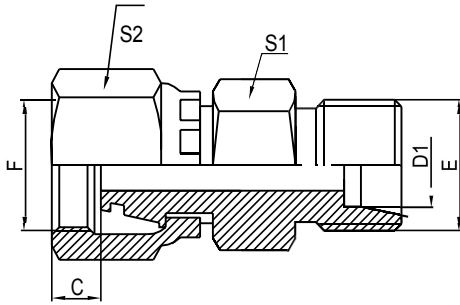

## 2D

公制内螺纹24° / 公制外螺纹24° 重系列  
METRIC FEMALE 24° / METRIC MALE 24° H.T.

代号 PART NO.	螺纹 THREADE		管子外径 TUBE O.D.		尺寸 DIMENSIONS				
	E	F	D1		C		S1	S2	
2D-14-16	M14x1.5	M16x1.5	6		3.5		14	22	
2D-14-18	M14x1.5	M18x1.5	6		3		17	24	
2D-14-20	M14x1.5	M20x1.5	6		3		19	27	
2D-16-18	M16x1.5	M18x1.5	8		3		17	24	
2D-16-20	M16x1.5	M20x1.5	8		3		19	27	
2D-16-22	M16x1.5	M22x1.5	8		2.5		22	27	
2D-18-20	M18x1.5	M20x1.5	10		3		19	27	
2D-18-22	M18x1.5	M22x1.5	10		2.5		22	27	
2D-20-22	M20x1.5	M22x1.5	12		2.5		22	27	
2D-16-24	M16x1.5	M24x1.5	8		3.5		22	30	
2D-18-24	M18x1.5	M24x1.5	10		3.5		22	30	
2D-20-24	M20x1.5	M24x1.5	12		3.5		22	30	
2D-20-30	M20x1.5	M30x2	12		4.5		30	36	
2D-22-24	M22x1.5	M24x1.5	14		3.5		22	30	
2D-22-30	M22x1.5	M30x2	14		4.5		30	36	
2D-24-30	M24x1.5	M30x2	16		4.5		27	36	
2D-30-36	M30x2	M36x2	20		3.5		36	41	
2D-30-42	M30x2	M42x2	20		5.5		41	50	
2D-33-42	M33x2	M42x2	22		5.5		41	50	
2D-33-52	M33x2	M52x2	22		7		50	60	
2D-42-52	M42x2	M52x2	30		7		50	60	

备注:如需带卡套及卡套螺母整套订货,则请在代号后加"RN",如"2D-22-30RN"

Remark: In case if you are interested to order the adapter in complete set with cutting ring and nut, it is necessary to insert suffix "RN" after our part NO., for example 2D-22-30RN.

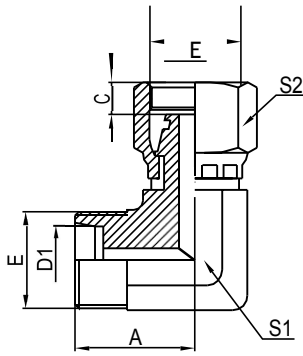

# 2C9

90° 公制内螺纹24° /  
公制外螺纹24° 轻系列  
90° METRIC FEMALE 24° /  
METRIC MALE 24° L.T.

代号 PART NO.	螺纹 THREADE		管子外径 TUBE O.D.		尺寸 DIMENSIONS				
	E	F	D1		A	C	S1	S2	
2C9-12	M12x1.5	M12x1.5	6		25	2	11	17	
2C9-14	M14x1.5	M14x1.5	8		29	3.5	14	19	
2C9-16	M16x1.5	M16x1.5	10		30	3.5	17	22	
2C9-18	M18x1.5	M18x1.5	12		33	3.5	19	24	
2C9-22	M22x1.5	M22x1.5	15		37	3	22	27	
2C9-26	M26x1.5	M26x1.5	18		41	3.5	27	32	
2C9-30	M30x2	M30x2	22		41	4.5	27	36	
2C9-36	M36x2	M36x2	28		46	4.5	33	41	
2C9-45	M45x2	M45x2	35		55	5.5	44	55	
2C9-52	M52x2	M52x2	42		59	6.5	55	60	

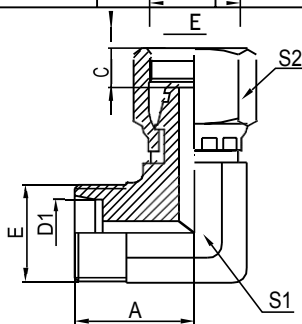

# 2D9

90° 公制内螺纹24° /  
公制外螺纹24° 重系列  
90° METRIC FEMALE 24° /  
METRIC MALE 24° H.T.

代号 PART NO.	螺纹 THREADE		管子外径 TUBE O.D.		尺寸 DIMENSIONS				
	E	F	D1		A	C	S1	S2	
2D9-14	M14x1.5	M14x1.5	6		29	3	14	19	
2D9-16	M16x1.5	M16x1.5	8		30	3.5	17	22	
2D9-18	M18x1.5	M18x1.5	10		33	3	19	24	
2D9-20	M20x1.5	M20x1.5	12		37	3	22	27	
2D9-22	M22x1.5	M22x1.5	14		37	2.5	22	27	
2D9-30	M30x2	M30x2	20		41	4.5	27	36	
2D9-36	M36x2	M36x2	25		46	3.5	33	41	
2D9-42	M42x2	M42x2	30		55	5.5	44	50	
2D9-52	M52x2	M52x2	38		59	7	55	60	

备注:如需带卡套及卡套螺母整套订货,则请在代号后加"RN",如"2D9-22RN" (同上)

Remark: In case if you are interested to order the adapter in complete set with cutting ring and nut, it is necessary to insert suffix "RN" after our part NO., for example 2D9-22RN. (the same with above)

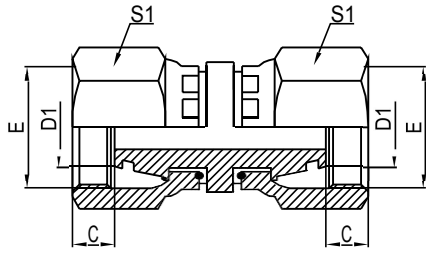

# 3C

公制内螺纹24°轻系列  
METRIC FEMALE 24° L.T.

代号 PART NO.	螺纹 THREADE		管子外径 TUBE O.D.		尺寸 DIMENSIONS C				
	E		D1			S1			
3C-12	M12x1.5		6			2	17		
3C-14	M14x1.5		8			3.5	19		
3C-16	M16x1.5		10			3.5	22		
3C-18	M18x1.5		12			3.5	24		
3C-22	M22x1.5		15			3	27		
3C-26	M26x1.5		18			3.5	32		
3C-30	M30x2		22			4.5	36		
3C-36	M36x2		28			4.5	41		
3C-45	M45x2		35			5.5	55		
3C-52	M52x2		42			6.5	60		

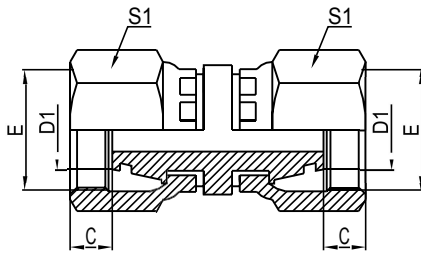

# 3D

公制内螺纹24°重系列  
METRIC FEMALE 24° H.T.

代号 PART NO.	螺纹 THREADE		管子外径 TUBE O.D.		尺寸 DIMENSIONS				
	E		D1		C	S1			
3D-14	M14x1.5		6			3	19		
3D-16	M16x1.5		8			3.5	22		
3D-18	M18x1.5		10			3	24		
3D-20	M20x1.5		12			3	27		
3D-22	M22x1.5		14			2.5	27		
3D-24	M24x1.5		16			3.5	30		
3D-30	M30x2		20			4.5	36		
3D-36	M36x2		25			3.5	41		
3D-42	M42x2		30			5.5	50		
3D-52	M52x2		38			7	60		



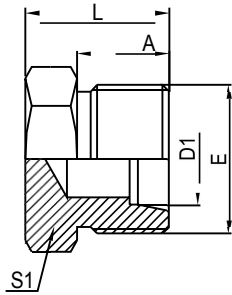

# 4C

公制螺纹24°轻系列堵头  
METRIC MALE 24° L.T. PULG

代号 PART NO.	螺纹 THREADE		管子外径 TUBE O.D.		尺寸 DIMENSIONS				
	E		D1		A		S1		L
4C-12	M12x1.5		6		10		12		16
4C-14	M14x1.5		8		11		14		17
4C-16	M16x1.5		10		11		17		17
4C-18	M18x1.5		12		11.5		19		17.5
4C-22	M22x1.5		15		12.5		24		20
4C-26	M26x1.5		18		12		27		22
4C-30	M30x2		22		14		32		25
4C-36	M36x2		28		16		36		27
4C-45	M45x2		35		18		46		31
4C-52	M52x2		42		19		55		36

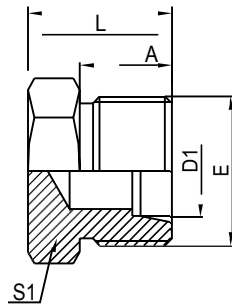

# 4D

公制螺纹24°重系列堵头  
METRIC MALE 24° H.T. PLUG

代号 PART NO.	螺纹 THREADE		管子外径 TUBE O.D.		尺寸 DIMENSIONS				
	E		D1		A		S1		L
4D-14	M14x1.5		6		12		14		18
4D-16	M16x1.5		8		12		17		18
4D-18	M18x1.5		10		12		19		18
4D-20	M20x1.5		12		12		22		19
4D-22	M22x1.5		14		14		24		22
4D-30	M30x2		20		16		32		26
4D-36	M36x2		25		18		36		29
4D-42	M42x2		30		20		46		32
4D-52	M52x2		38		22		55		39

备注:如需带卡套及卡套螺母整套订货,则请在代号后加"RN",如"4D-22RN" (同上)

Remark: In case if you are interested to order the adapter in complete set with cutting ring and nut, it is necessary to insert suffix "RN" arter our part NO., for example 4D-22RN. (the same with above)

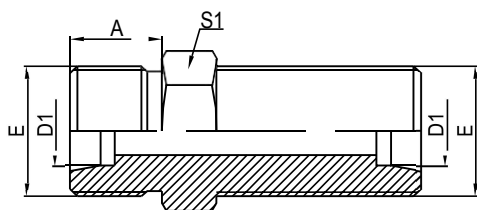

# 6C

公制外螺纹24°轻系列过板接头  
METRIC MALE 24° L.T. BULKHEAD

代号 PART NO.	螺纹 THREADS		管子外径 TUBE O.D.		尺寸 DIMENSIONS				
	E		D1		A		S1		
6C-12	M12x1.5		6		10		12		
6C-14	M14x1.5		8		11		14		
6C-16	M16x1.5		10		11		17		
6C-18	M18x1.5		12		11.5		19		
6C-22	M22x1.5		15		12.5		24		
6C-26	M26x1.5		18		12		27		
6C-30	M30x2		22		14		32		
6C-33	M33x2		25		16		36		
6C-45	M45x2		35		18		46		
6C-52	M52x2		42		19		55		

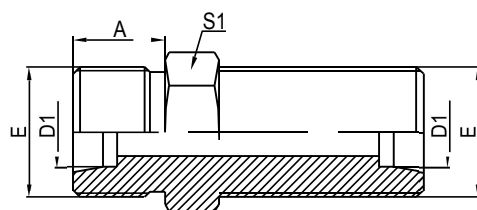

# 6D

公制外螺纹24°重系列过板接头  
METRIC MALE 24° H.T. BULKHEAD

代号 PART NO.	螺纹 THREADS		管子外径 TUBE O.D.		尺寸 DIMENSIONS				
	E		D1		A		S1		
6D-14	M14x1.5		6		12		14		
6D-16	M16x1.5		8		12		17		
6D-18	M18x1.5		10		12		19		
6D-20	M20x1.5		12		12		22		
6D-22	M22x1.5		14		14		24		
6D-24	M24x1.5		16		14		27		
6D-30	M30x2		20		16		32		
6D-36	M36x2		25		18		36		
6D-42	M42x2		30		20		46		
6D-52	M52x2		38		22		55		

备注:如需带卡套及卡套螺母整套订货,则请在代号后加"RN",如"6D-22RN"、如需带锁母订货,请在代号后加"LN",如"6D-22LN"(同上)

Remark: In case if you are interested to order the adapter in complete set with cutting ring and nut, it is necessary to insert suffix "RN" after our part NO., for example 6D-22RN. order the adapter with cutting ring and nut, insert suffix "LN" after part NO for example "6D-22LN" (the same with above)

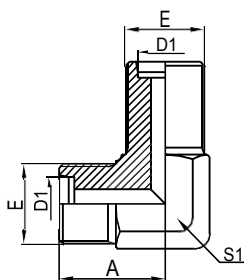

# 6C9

90° 公制外螺纹24° 轻系列过板接头  
90° METRIC MALE 24° L.T. BULKHEAD

代号 PART NO.	螺纹 THREADE		管子外径 TUBE O.D.	尺寸 DIMENSIONS			
	E			A		S1	
6C9-12	M12x1.5		6	25		11	
6C9-14	M14x1.5		8	29		14	
6C9-16	M16x1.5		10	30		17	
6C9-18	M18x1.5		12	33		19	
6C9-22	M22x1.5		15	37		22	
6C9-26	M26x1.5		18	41		27	
6C9-30	M30x2		22	41		27	
6C9-36	M36x2		28	46		33	
6C9-45	M45x2		35	55		44	
6C9-52	M52x2		42	59		55	

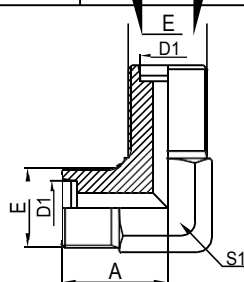

# 6D9

90° 公制外螺纹24° 重系列过板接头  
90° METRIC MALE 24° H.T. BULKHEAD

代号 PART NO.	螺纹 THREADE		管子外径 TUBE O.D.	尺寸 DIMENSIONS			
	E			A		S1	
6D9-14	M14x1.5		6	29		14	
6D9-16	M16x1.5		8	30		17	
6D9-18	M18x1.5		10	33		19	
6D9-20	M20x1.5		12	37		22	
6D9-22	M22x1.5		14	37		22	
6D9-30	M30x2		20	41		27	
6D9-36	M36x2		25	41		27	
6D9-42	M42x2		30	55		44	
6D9-52	M52x2		38	59		55	

备注:如需带卡套及卡套螺母整套订货,则请在代号后加"RN",如"6D9-22RN"、如需带锁母订货,请在代号后加"LN",如"6D9-22LN"(同上)

Remark:In case if you are interested to order the adapter in complete set with cutting ring and nut,it is necessary to insert suffix"RN" arter our part NO.,for example 6D9-22RN.order the adapter with cutting ring and nut,insert suffix"LN"after part NO for example "6D9-22LN"(the same with above)

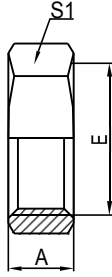

# 8C

公制螺纹锁母  
METRIC LOCK NUT

代号 PART NO.	螺纹 THREADE				尺寸 DIMENSIONS				
	E				A		S1		
8C-10	M10x1				6		14		
8C-12	M12x1.5				7.5		17		
8C-14	M14x1.5				7.5		19		
8C-16	M16x1.5				7.5		22		
8C-18	M18x1.5				7.5		24		
8C-20	M20x1.5				8		27		
8C-22	M22x1.5				8		27		
8C-24	M24x1.5				8		30		
8C-26	M26x1.5				8		32		
8C-27D	M27x1.5				10		32		
8C-30	M30x2				10		36		
8C-30D	M30x1.5				10		36		
8C-36	M36x2				10		41		
8C-38	M38x2				10		46		
8C-42	M42x2				10		50		
8C-45	M45x2				10		55		
8C-52	M52x2				10		60		

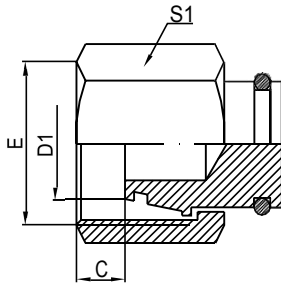

# 9C

公制内螺纹24°轻系列堵头  
METRIC FEMALE 24° L.T. PLUG

代号 PART NO.	螺纹 THREADE		管子外径 TUBE O.D.		尺寸 DIMENSIONS C				
	E		D1				S1		
9C-12	M12x1.5		6			2	14		
9C-14	M14x1.5		8			2	17		
9C-16	M16x1.5		10			2	19		
9C-18	M18x1.5		12			2.5	22		
9C-22	M22x1.5		15			3	27		
9C-26	M26x1.5		18			3.5	32		
9C-30	M30x2		22			3.5	36		
9C-36	M36x2		28			4	41		
9C-45	M45x2		35			5	55		
9C-52	M52x2		42			6	60		

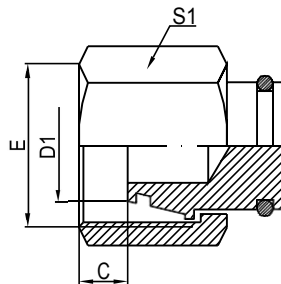

# 9D

公制内螺纹24°重系列堵头  
METRIC FEMALE 24° H.T. PLUG

代号 PART NO.	螺纹 THREADE		管子外径 TUBE O.D.		尺寸 DIMENSIONS				
	E		D1			C	S1		
9D-16	M16x1.5		8			2	19		
9D-18	M18x1.5		10			2	22		
9D-20	M20x1.5		12			3	24		
9D-22	M22x1.5		14			2.5	27		
9D-24	M24x1.5		16			3	30		
9D-30	M30x2		20			3.5	36		
9D-36	M36x2		25			3	41		
9D-42	M42x2		30			5	50		
9D-52	M52x2		38			6.5	60		

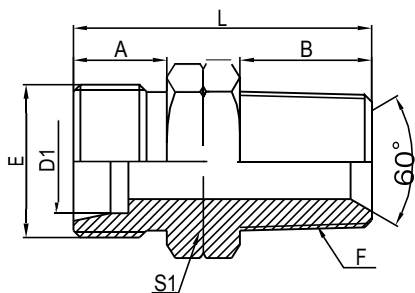

# 1CN

公制外螺纹24°轻系列/  
布锥管外螺纹60°  
METRIC MALE 24° L.T.  
/NPT MALE 60°

代号 PART NO.	螺纹 THREADE		管子外径 TUBE O.D.		尺寸 DIMENSIONS				
	E	F	D1		A	B	S1		L
1CN-12-02	M12x1.5	Z1/8"X27	6		10	10	12		26
1CN-12-04	M12x1.5	Z1/4"X18	6		10	14	14		31
1CN-14-04	M14x1.5	Z1/4"X18	8		11	14	14		31
1CN-16-04	M16x1.5	Z1/4"X18	10		11	14	17		32.5
1CN-16-06	M16x1.5	Z3/8"X18	10		11	14	17		32.5
1CN-18-04	M18x1.5	Z1/4"X18	12		11.5	14	19		31.5
1CN-18-06	M18x1.5	Z3/8"X18	12		11.5	14	19		31.5
1CN-18-08	M18x1.5	Z1/2"X14	12		11.5	19	22		38
1CN-22-08	M22x1.5	Z1/2"X14	15		12.5	19	24		39
1CN-22-20	M22x1.5	Z1.1/4"X11.5	15		12.5	25	46		50.5
1CN-26-08	M26x1.5	Z1/2"X14	18		12	19	27		40
1CN-26-12	M26x1.5	Z3/4"X14	18		12	19.5	27		40
1CN-30-08	M30x2	Z1/2"X14	22		14	19	32		43
1CN-30-12	M30x2	Z3/4"X14	22		14	19.5	32		43.5
1CN-36-16	M36x2	Z1"X11.5	28		16	24	36		51
1CN-36-20	M36x2	Z1.1/4"X11.5	28		16	25	46		54
1CN-45-20	M45x2	Z1.1/4"X11.5	35		18	25	46		56
1CN-52-20	M52x2	Z1.1/4"X11.5	42		19	25	55		61
1CN-52-24	M52x2	Z1.1/2"X11.5	42		19	25	55		61

备注:如需带卡套及卡套螺母整套订货,则请在代号后加"RN",如"1CN-22-08RN"

Remark:In case if you are interested to order the adapter in complete set with cutting ring and nut,it is necessary to insert suffix"RN" arter our part NO.,for example 1CN-22-08RN.

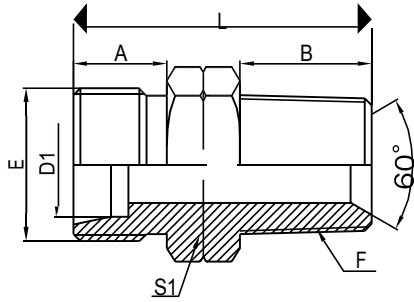

# 1DN

公制外螺纹24°重系列/  
布锥管外螺纹60°  
METRIC MALE 24° H.T.  
/NPT MALE 60°

代号 PART NO.	螺纹 THREADE		管子外径 TUBE O.D.		尺寸 DIMENSIONS				
	E	F	D1		A	B	S1		L
1DN-14-04	M14x1.5	Z1/4"X18	6		12	14	14		32
1DN-16-04	M16x1.5	Z1/4"X18	8		12	14	17		32
1DN-18-04	M18x1.5	Z1/4"X18	10		12	14	19		32
1DN-18-06	M18x1.5	Z3/8"X18	10		12	14	19		32
1DN-20-04	M20x1.5	Z1/4"X18	12		12	14	22		33
1DN-20-06	M20x1.5	Z3/8"X18	12		12	14	22		33
1DN-20-08	M20x1.5	Z1/2"X14	12		12	19	22		38
1DN-22-08	M22x1.5	Z1/2"X14	14		14	19	24		41
1DN-24-08	M24x1.5	Z1/2"X14	16		14	19	27		42
1DN-30-12	M30x2	Z3/4"X14	20		16	19.5	32		45.5
1DN-36-16	M36x2	Z1"X11.5	25		18	24	36		53
1DN-42-16	M42x2	Z1"X11.5	30		20	24	46		57
1DN-42-20	M42x2	Z1.1/4"X11.5	30		20	25	46		58
1DN-52-24	M52x2	Z1.1/2"X11.5	38		22	25	55		64

备注: 如需带卡套及卡套螺母整套订货, 则请在代号后加"RN", 如"1DN-22-08RN"

Remark: In case if you are interested to order the adapter in complete set with cutting ring and nut, it is necessary to insert suffix "RN" arter our part NO., for example 1DN-22-08RN.

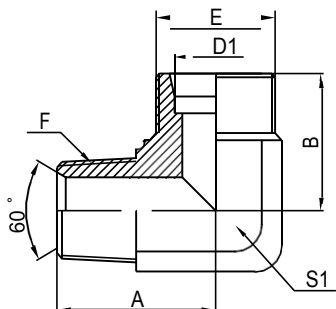

# 1CN9

90° 公制外螺纹24° 轻系列/  
布锥管外螺纹60°  
90° METRIC MALE 24° L.T.  
/NPT MALE 60°

代号 PART NO.	螺纹 THREADE		管子外径 TUBE O.D.		尺寸 DIMENSIONS				
	E	F	D1		A	B	S1		
1CN9-12-02	M12x1.5	Z1/8"X27	6		25	25	11		
1CN9-12-04	M12x1.5	Z1/4"X18	6		27	29	14		
1CN9-14-04	M14x1.5	Z1/4"X18	8		27	29	14		
1CN9-16-06	M16x1.5	Z3/8"X18	10		29	30	17		
1CN9-18-04	M18x1.5	Z1/4"X18	12		33	33	19		
1CN9-18-06	M18x1.5	Z3/8"X18	12		33	33	19		
1CN9-18-08	M18x1.5	Z1/2"X14	12		37	37	22		
1CN9-22-06	M22x1.5	Z3/8"X18	15		37	37	22		
1CN9-22-08	M22x1.5	Z1/2"X14	12		37	37	22		
1CN9-26-08	M26x1.5	Z1/2"X14	18		41	41	27		
1CN9-26-12	M26x1.5	Z3/4"X14	18		41	41	27		
1CN9-30-12	M30x2	Z3/4"X14	22		41	41	27		
1CN9-30-16	M30x2	Z1"X11.5	22		49	49	33		
1CN9-36-16	M36x2	Z1"X11.5	28		46	46	33		
1CN9-45-20	M45x2	Z1.1/4"X11.5	35		55	55	44		
1CN9-52-24	M52x2	Z1.1/2"X11.5	42		57	60	55		

备注:如需带卡套及卡套螺母整套订货,则请在代号后加"RN",如"1CN9-22-08RN"

Remark: In case if you are interested to order the adapter in complete set with cutting ring and nut, it is necessary to insert suffix "RN" arter our part NO., for example 1CN9-22-08RN.



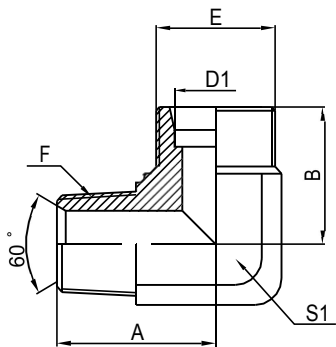

# 1DN9

90° 公制外螺纹24° 重系列  
/ 布锥管外螺纹60°  
90° METRIC MALE 24° H.T.  
/ NPT MALE 60°

代号 PART NO.	螺纹 THREADE		管子外径 TUBE O.D.		尺寸 DIMENSIONS				
	E	F	D1		A	B	S1		
1DN9-14-04	M14x1.5	Z1/4"X18	6		27	29	14		
1DN9-16-04	M16x1.5	Z1/4"X18	8		29	30	17		
1DN9-18-06	M18x1.5	Z3/8"X18	10		33	33	19		
1DN9-20-04	M20x1.5	Z1/4"X18	12		37	37	22		
1DN9-20-06	M20x1.5	Z3/8"X18	12		37	37	22		
1DN9-22-06	M22x1.5	Z3/8"X18	14		37	37	22		
1DN9-22-08	M22x1.5	Z1/2"X14	14		37	37	22		
1DN9-24-06	M24x1.5	Z3/8"X18	16		37	33	24		
1DN9-24-08	M24x1.5	Z1/2"X14	16		33	37	24		
1DN9-30-08	M30x2	Z1/2"X14	20		40	40	27		
1DN9-30-12	M30x2	Z3/4"X14	20		40	40	27		
1DN9-36-16	M36x2	Z1"X11.5	28		49	49	33		
1DN9-42-16	M42x2	Z1"X11.5	30		57	57	44		
1DN9-42-20	M42x2	Z1.1/4"X11.5	30		57	57	44		
1DN9-52-20	M52x2	Z1.1/4"X11.5	38		56	60	55		
1DN9-52-24	M52x2	Z1.1/2"X11.5	38		56	60	55		

备注: 如需带卡套及卡套螺母整套订货, 则请在代号后加"RN", 如"1DN9-22-08RN"

Remark: In case if you are interested to order the adapter in complete set with cutting ring and nut, it is necessary to insert suffix "RN" arter our part NO., for example 1DN9-22-08RN.

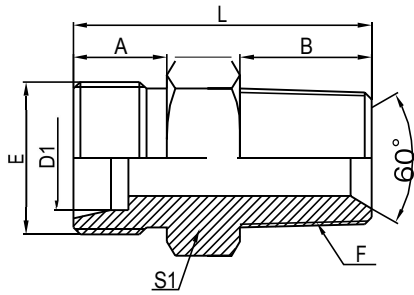

# 1CT

公制外螺纹24°轻系列/  
 英锥管外螺纹60°  
 METRIC MALE 24° L.T./  
 BSPT MALE 60°

代号 PART NO.	螺纹 THREADE		管子外径 TUBE O.D.		尺寸 DIMENSIONS				
	E	F	D1		A	B	S1		L
1CT-12-02	M12x1.5	ZG1/8"X28	6		10	10	12		26
1CT-12-04	M12x1.5	ZG1/4"X19	6		10	14	14		31
1CT-14-04	M14x1.5	ZG1/4"X19	8		11	14	14		31
1CT-16-04	M16x1.5	ZG1/4"X19	10		11	14	17		32.5
1CT-16-06	M16x1.5	ZG3/8"X19	10		11	14	17		32.5
1CT-18-04	M18x1.5	ZG1/4"X19	12		11.5	14	19		31.5
1CT-18-06	M18x1.5	ZG3/8"X19	12		11.5	14	19		31.5
1CT-18-08	M18x1.5	ZG1/2"X14	12		11.5	19	22		38
1CT-22-08	M22x1.5	ZG1/2"X14	15		12.5	19	24		39
1CT-22-20	M22x1.5	ZG1.1/4"X11	15		12.5	25	46		50.5
1CT-26-08	M26x1.5	ZG1/2"X14	18		12	19	27		40
1CT-26-12	M26x1.5	ZG3/4"X14	18		12	19.5	27		40
1CT-30-08	M30x2	ZG1/2"X14	22		14	19	32		43
1CT-30-12	M30x2	ZG3/4"X14	22		14	19.5	32		43.5
1CT-36-16	M36x2	ZG1"X11	28		16	24	36		51
1CT-36-20	M36x2	ZG1.1/4"X11	28		16	25	46		54
1CT-45-20	M45x2	ZG1.1/4"X11	35		18	25	46		56
1CT-52-20	M52x2	ZG1.1/4"X11	42		19	25	55		61
1CT-52-24	M52x2	ZG1.1/2"X11	42		19	25	55		61

备注:如需带卡套及卡套螺母整套订货,则请在代号后加"RN",如"1CT-22-08RN"

Remark:In case if you are interested to order the adapter in complete set with cutting ring and nut,it is necessary to insert suffix"RN" arter our part NO.,for example 1CT-22-08RN.

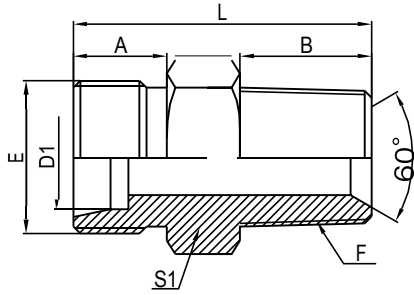

# 1DT

公制外螺纹24°重系列/  
 英锥管外螺纹60°  
 METRIC MALE 24° H.T./  
 BSPT MALE 60°

代号 PART NO.	螺纹 THREADE		管子外径 TUBE O.D.		尺寸 DIMENSIONS				
	E	F	D1		A	B	S1		L
1DT-14-04	M14x1.5	ZG1/4"X19	6		12	14	14		32
1DT-16-04	M16x1.5	ZG1/4"X19	8		12	14	17		32
1DT-18-04	M18x1.5	ZG1/4"X19	10		12	14	19		32
1DT-18-06	M18x1.5	ZG3/8"X19	10		12	14	19		32
1DT-20-04	M20x1.5	ZG1/4"X19	12		12	14	22		33
1DT-20-06	M20x1.5	ZG3/8"X19	12		12	14	22		33
1DT-20-08	M20x1.5	ZG1/2"X14	12		12	19	22		38
1DT-22-08	M22x1.5	ZG1/2"X14	14		14	19	24		41
1DT-24-08	M24x1.5	ZG1/2"X14	16		14	19	27		42
1DT-30-12	M30x2	ZG3/4"X14	20		16	19.5	32		45.5
1DT-36-16	M36x2	ZG1"X11	25		18	24	36		53
1DT-42-16	M42x2	ZG1"X11	30		20	24	46		57
1DT-42-20	M42x2	ZG1.1/4"X11	30		20	25	46		58
1DT-52-24	M52x2	ZG1.1/4"X11	38		22	25	55		64

备注:如需带卡套及卡套螺母整套订货,则请在代号后加"RN",如"1CT-22-08RN"

Remark: In case if you are interested to order the adapter in complete set with cutting ring and nut, it is necessary to insert suffix "RN" arter our part NO., for example 1CT-22-08RN.

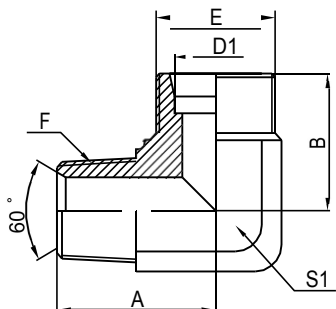

# 1CT9

90° 公制外螺纹24° 轻系列/  
 英锥管外螺纹60° 90°  
 METRIC MALE 24° L.T./  
 BSPT MALE 60°

代号 PART NO.	螺纹 THREADE		管子外径 TUBE O.D.		尺寸 DIMENSIONS				
	E	F	D1		A	B	S1		
1CT9-12-02	M12x1.5	ZG1/8"X28	6		25	25	11		
1CT9-12-04	M12x1.5	ZG1/4"X19	6		27	29	14		
1CT9-14-04	M14x1.5	ZG1/4"X19	8		27	29	14		
1CT9-16-06	M16x1.5	ZG3/8"X19	10		29	30	17		
1CT9-18-04	M18x1.5	ZG1/4"X19	12		33	33	19		
1CT9-18-06	M18x1.5	ZG3/8"X19	12		33	33	19		
1CT9-18-08	M18x1.5	ZG1/2"X14	12		37	37	22		
1CT9-22-06	M22x1.5	ZG3/8"X19	15		37	37	22		
1CT9-22-08	M22x1.5	ZG1/2"X14	12		37	37	22		
1CT9-26-08	M26x1.5	ZG1/2"X14	18		41	41	27		
1CT9-26-12	M26x1.5	ZG3/4"X14	18		41	41	27		
1CT9-30-12	M30x2	ZG3/4"X14	22		41	41	27		
1CT9-30-16	M30x2	ZG1"X11	22		49	49	33		
1CT9-36-16	M36x2	ZG1"X11	28		46	46	33		
1CT9-45-20	M45x2	ZG1.1/4"X11	35		55	55	44		
1CT9-52-24	M52x2	ZG1.1/2"X11	42		57	60	55		

备注:如需带卡套及卡套螺母整套订货,则请在代号后加"RN",如"1CT9-22-08RN"  
 Remark:In case if you are interested to order the adapter in complete set with cutting ring and nut,it is necessary to insert suffix"RN" arter our part NO.,for example 1CT9-22-08RN.

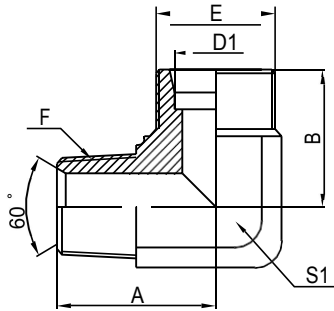

# 1DT9

90° 公制外螺纹24° /  
 英锥管外螺纹60° 重系列  
 90° METRIC MALE 24° /  
 BSPT MALE 60° H.T.

代号 PART NO.	螺纹 THREADE		管子外径 TUBE O.D.		尺寸 DIMENSIONS				
	E	F	D1		A	B	S1		
1DT9-14-04	M14x1.5	ZG1/4"X19	6		27	29	14		
1DT9-16-04	M16x1.5	ZG1/4"X19	8		29	30	17		
1DT9-18-06	M18x1.5	ZG3/8"X19	10		33	33	19		
1DT9-20-04	M20x1.5	ZG1/4"X19	12		37	37	22		
1DT9-20-06	M20x1.5	ZG3/8"X19	12		37	37	22		
1DT9-22-06	M22x1.5	ZG3/8"X19	14		37	37	22		
1DT9-22-08	M22x1.5	ZG1/2"X14	14		37	37	22		
1DT9-24-06	M24x1.5	ZG3/8"X19	16		37	33	24		
1DT9-24-08	M24x1.5	ZG1/2"X14	16		33	37	24		
1DT9-30-08	M30x2	ZG1/2"X14	20		40	40	27		
1DT9-30-12	M30x2	ZG3/4"X14	20		40	40	27		
1DT9-36-16	M36x2	ZG1"X11	25		49	49	33		
1DT9-42-16	M42x2	ZG1"X11	30		57	57	44		
1DT9-42-20	M42x2	ZG1.1/4"X11	30		57	57	44		
1DT9-52-20	M52x2	ZG1.1/4"X11	38		56	60	55		
1DT9-52-24	M52x2	ZG1.1/2"X11	38		56	60	55		

备注:如需带卡套及卡套螺母整套订货,则请在代号后加"RN",如"1DT9-22-08RN"

Remark: In case if you are interested to order the adapter in complete set with cutting ring and nut, it is necessary to insert suffix "RN" arter our part NO., for example 1DT9-22-08RN.

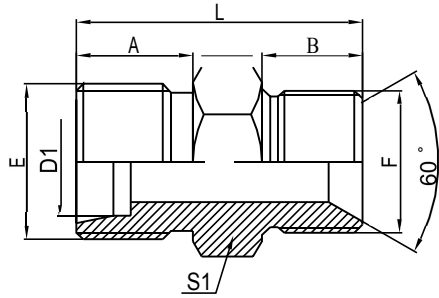

# 1CB

公制外螺纹24°轻系列/英管螺纹  
或60°锥面组合垫密封  
METRIC MALE 24° SEAL L.T./BSP MALE  
DOUBLE 60° SEAT BONDED SEAL

代号 PART NO.	螺纹 THREADS		管子外径 TUBE O.D.		尺寸 DIMENSIONS				
	E	F	D1		A	B	S1		L
1CB-12-02	M12x1.5	G1/8"X28	6		10	10	14		26
1CB-12-04	M12x1.5	G1/4"X19	6		10	12	19		28
1CB-14-02	M14x1.5	G1/8"X28	8		11	10	14		27
1CB-14-04	M14x1.5	G1/4"X19	8		11	12	19		29
1CB-14-06	M14x1.5	G3/8"X19	8		11	13.5	22		32
1CB-16-04	M16x1.5	G1/4"X19	10		11	12	19		29
1CB-16-06	M16x1.5	G3/8"X19	10		11	13.5	22		32.5
1CB-16-08	M16x1.5	G1/2"X14	10		11	16	27		37
1CB-18-04	M18x1.5	G1/4"X19	12		11.5	12	19		29.5
1CB-18-06	M18x1.5	G3/8"X19	12		11.5	13.5	22		32
1CB-18-08	M18x1.5	G1/2"X14	12		11.5	16	27		36
1CB-18-12	M18x1.5	G3/4"X14	12		11.5	18.5	32		40
1CB-22-06	M22x1.5	G3/8"X19	15		12.5	13.5	22		33
1CB-22-08	M22x1.5	G1/2"X14	15		12.5	16	27		37
1CB-26-08	M26x1.5	G1/2"X14	18		12	16	27		37
1CB-26-12	M26x1.5	G3/4"X14	18		12	18.5	32		41.5
1CB-30-12	M30x2	G3/4"X14	22		14	18.5	32		42.5
1CB-36-16	M36x2	G1"X11	28		16	20.5	41		48.5
1CB-45-20	M45x2	G1.1/4"X11	35		18	20.5	50		55.5
1CB-52-24	M52x2	G1.1/2"X11	42		19	23	55		59

备注:如需带卡套及卡套螺母整套订货,则请在代号后加"RN",如"1CB-22-08RN"

Remark:In case if you are interested to order the adapter in complete set with cutting ring and nut,it is necessary to insert suffix"RN" arter our part NO.,for example 1CB-22-08RN.

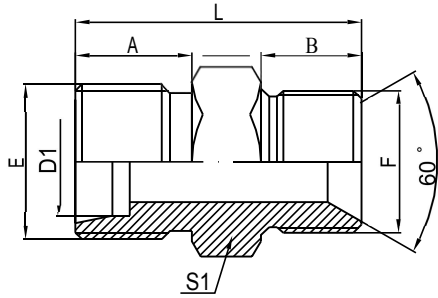

# 1DB

公制外螺纹24°重系列/英管螺纹  
或60°锥面或组合垫密封  
METRIC MALE 24° SEAL H.T./BSP MALE  
DOUBLE 60° SEAT BONDED SEAL

代号 PART NO.	螺纹 THREADE		管子外径 TUBE O.D.	尺寸 DIMENSIONS				
	E	F		A	B	S1	L	
1DB-14-04	M14x1.5	G1/4"X19	6	12	12	19		30
1DB-16-04	M16x1.5	G1/4"X19	8	12	12	19		30
1DB-16-06	M16x1.5	G3/8"X19	8	12	13.5	22		33
1DB-18-04	M18x1.5	G1/4"X19	10	12	12	19		30
1DB-18-06	M18x1.5	G3/8"X19	10	12	13.5	22		33
1DB-18-08	M18x1.5	G1/2"X14	10	12	16	27		37
1DB-20-04	M20x1.5	G1/4"X19	12	12	12	22		31
1DB-20-06	M20x1.5	G3/8"X19	12	12	13.5	22		33
1DB-20-08	M20x1.5	G1/2"X14	12	12	16	27		37
1DB-22-08	M22x1.5	G1/2"X14	14	14	16	27		39
1DB-24-06	M24x1.5	G3/8"X19	16	14	13.5	27		36
1DB-24-08	M24x1.5	G1/2"X14	16	14	16	27		39
1DB-24-12	M24x1.5	G3/4"X14	16	14	18.5	32		42.5
1DB-30-12	M30x2	G3/4"X14	20	16	18.5	32		44.5
1DB-36-16	M36x2	G1"X11	25	18	20.5	41		50.5
1DB-42-20	M42x2	G1.1/4"X11	30	20	20.5	50		57.5
1DB-52-24	M52x2	G1.1/2"X11	38	22	23	55		62

备注:如需带卡套及卡套螺母整套订货,则请在代号后加"RN",如"1DB-22-08RN"

Remark: In case if you are interested to order the adapter in complete set with cutting ring and nut, it is necessary to insert suffix "RN" after our part NO., for example 1DB-22-08RN.

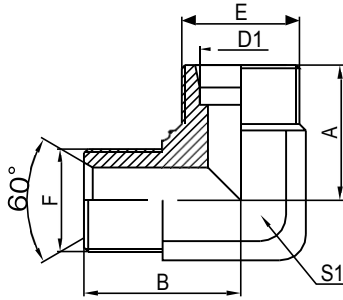

# 1CB9

90° 公制外螺纹24° 轻系列/  
 英管螺纹60° 锥面密封90°  
 METRIC MALE 24° L.T.  
 /BSP MALE 60° CONE

代号 PART NO.	螺纹 THREADE		管子外径 TUBE O.D.		尺寸 DIMENSIONS				
	E	F	D1		A	B	S1		
1CB9-12-04	M12x1.5	G1/4"X19	6		29	27	14		
1CB9-14-04	M14x1.5	G1/4"X19	8		29	27	14		
1CB9-14-06	M14x1.5	G3/8"X19	8		30	29	17		
1CB9-16-04	M16x1.5	G1/4"X19	10		30	29	17		
1CB9-16-06	M16x1.5	G3/8"X19	10		30	29	17		
1CB9-16-08	M16x1.5	G1/2"X14	10		37	37	22		
1CB9-18-04	M18x1.5	G1/4"X19	12		33	33	19		
1CB9-18-06	M18x1.5	G3/8"X19	12		33	33	19		
1CB9-18-08	M18x1.5	G1/2"X14	12		37	37	22		
1CB9-22-06	M22x1.5	G3/8"X19	15		37	37	22		
1CB9-22-08	M22x1.5	G1/2"X14	15		37	37	22		
1CB9-26-08	M26x1.5	G1/2"X14	18		41	41	27		
1CB9-30-12	M30x2	G3/4"X14	22		40	40	27		
1CB9-36-16	M36x2	G1"X11	28		46	46	33		
1CB9-45-20	M45x2	G1.1/4"X11	35		55	55	44		
1CB9-52-24	M52x2	G1.1/2"X11	42		61	57	55		

备注: 如需带卡套及卡套螺母整套订货, 则请在代号后加"RN", 如"1CB9-22-08RN"  
 Remark: In case if you are interested to order the adapter in complete set with cutting ring and nut, it is necessary to insert suffix"RN" arter our part NO., for example 1CB9-22-08RN.



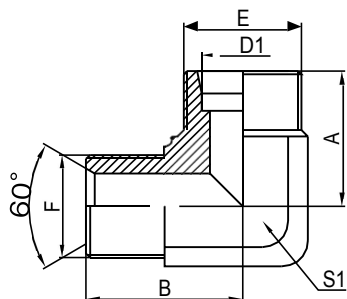

# 1DB9

90° 公制外螺纹24° 重系列/ 英  
管螺纹60° 锥面密封90°  
METRIC MALE 24° H.T./BSP  
MALE BSP MALE 60° CONE

代号 PART NO.	螺纹 THREADE		管子外径 TUBE O.D.		尺寸 DIMENSIONS				
	E	F	D1		A	B	S1		
1DB9-14-04	M14x1.5	G1/4"X19	6		29	27	14		
1DB9-16-04	M16x1.5	G1/4"X19	8		30	29	17		
1DB9-16-06	M16x1.5	G3/8"X19	8		30	29	17		
1DB9-18-04	M18x1.5	G1/4"X19	10		33	33	19		
1DB9-18-06	M18x1.5	G3/8"X19	10		33	33	19		
1DB9-18-08	M18x1.5	G1/2"X14	10		37	37	22		
1DB9-20-04	M20x1.5	G1/4"X19	12		37	37	22		
1DB9-20-06	M20x1.5	G3/8"X19	12		37	37	22		
1DB9-20-08	M20x1.5	G1/2"X14	12		37	37	22		
1DB9-22-08	M22x1.5	G1/2"X14	14		37	37	22		
1DB9-24-06	M24x1.5	G3/8"X19	16		37	33	24		
1DB9-24-08	M24x1.5	G1/2"X14	16		37	33	24		
1DB9-24-12	M24x1.5	G3/4"X14	16		41	41	27		
1DB9-30-12	M30x2	G3/4"X14	20		41	41	27		
1DB9-36-08	M36x2	G1/2"X14	25		49	49	33		
1DB9-36-12	M36x2	G3/4"X14	25		49	49	33		
1DB9-36-16	M36x2	G1"X11	25		49	49	33		
1DB9-42-20	M42x2	G1.1/4"X11	30		55	55	44		
1DB9-52-24	M52x2	G1.1/2"X11	38		61	57	55		

备注: 如需带卡套及卡套螺母整套订货, 则请在代号后加"RN", 如"1DB9-22-08RN"

Remark: In case if you are interested to order the adapter in complete set with cutting ring and nut, it is necessary to insert suffix "RN" arter our part NO., for example 1DB9-22-08RN.

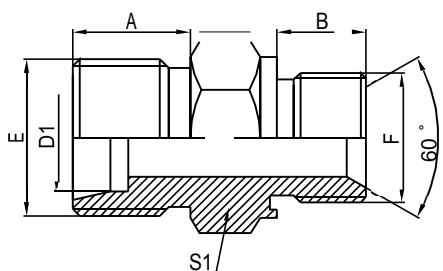

# 1CB-WD

公制外螺纹24°轻系列/ 英管螺纹  
60°内锥面或胶垫密封  
METRIC MALE 24° L.T./BSP THREAD  
WITH CAPTIVE SEAL

代号 PART NO.	螺纹 THREADE		管子外径 TUBE O.D.		尺寸 DIMENSIONS				
	E	F	D1		A	B	S1		
1CB-12-02WD	M12x1.5	G1/8"X28	6		10	10	12		
1CB-12-04WD	M12x1.5	G1/4"X19	6		10	12	19		
1CB-12-06WD	M12x1.5	G3/8"X19	6		10	13.5	22		
1CB-14-02WD	M14x1.5	G1/8"X28	8		11	10	14		
1CB-14-04WD	M14x1.5	G1/4"X19	8		11	12	19		
1CB-14-06WD	M14x1.5	G3/8"X19	8		11	13.5	22		
1CB-16-04WD	M16x1.5	G1/4"X19	10		11	12	19		
1CB-16-06WD	M16x1.5	G3/8"X19	10		11	13.5	22		
1CB-16-08WD	M16x1.5	G1/2"X14	10		11	16	27		
1CB-18-04WD	M18x1.5	G1/4"X19	12		11.5	12	19		
1CB-18-06WD	M18x1.5	G3/8"X19	12		11.5	13.5	22		
1CB-18-08WD	M18x1.5	G1/2"X14	12		11.5	16	27		
1CB-22-04WD	M22x1.5	G1/4"X19	15		12.5	12	22		
1CB-22-06WD	M22x1.5	G3/8"X19	15		12.5	13.5	22		
1CB-22-08WD	M22x1.5	G1/2"X14	15		12.5	16	27		
1CB-22-12WD	M22x1.5	G3/4"X14	15		12.5	18.5	32		
1CB-26-08WD	M26x1.5	G1/2"X14	18		12	16	27		
1CB-26-12WD	M26x1.5	G3/4"X14	18		12	18.5	32		
1CB-30-12WD	M30x2	G3/4"X14	22		14	18.5	32		
1CB-36-16WD	M36x2	G1"X11	28		16	20.5	41		
1CB-45-20WD	M45x2	G1.1/4"X11	35		18	20.5	50		
1CB-52-24WD	M52x2	G1.1/2"X11	42		19	23	55		

备注: 如需带卡套及卡套螺母整套订货, 则在代号后加"RN", 如"1CB-22-08WD/RN"

Remark: In case if you are interested to order the adapter in complete set with cutting ring and nut, it is necessary to insert suffix "RN" arter our part NO., for example 1CB-22-08WD/RN.

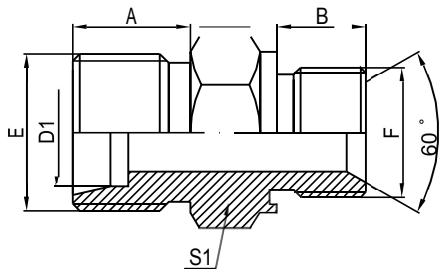

# 1DB-WD

公制外螺纹24°重系列/ 英管螺纹  
60°内锥面胶垫密封  
METRIC MALE 24° H.T./BSP THREAD  
WITH CAPTIVE SEAL

代号 PART NO.	螺纹 THREADE		管子外径 TUBE O.D.		尺寸 DIMENSIONS				
	E	F	D1		A	B	S1		
1DB-14-04WD	M14x1.5	G1/4"X19	6		12	12	19		
1DB-16-04WD	M16x1.5	G1/4"X19	8		12	12	19		
1DB-16-06WD	M16x1.5	G3/8"X19	8		12	13.5	22		
1DB-18-04WD	M18x1.5	G1/4"X19	10		12	12	19		
1DB-18-06WD	M18x1.5	G3/8"X19	10		12	13.5	22		
1DB-18-08WD	M18x1.5	G1/2"X14	10		12	16	27		
1DB-20-04WD	M20x1.5	G1/4"X19	12		12	12	22		
1DB-20-06WD	M20x1.5	G3/8"X19	12		12	13.5	22		
1DB-20-08WD	M20x1.5	G1/2"X14	12		12	16	27		
1DB-22-08WD	M22x1.5	G1/2"X14	14		14	16	27		
1DB-24-06WD	M24x1.5	G3/8"X19	16		14	13.5	27		
1DB-24-08WD	M24x1.5	G1/2"X14	16		14	16	27		
1DB-24-12WD	M24x1.5	G3/4"X14	16		14	18.5	32		
1DB-30-12WD	M30x2	G3/4"X14	20		16	18.5	32		
1DB-42-20WD	M42x2	G1.1/4"X11	30		20	20.5	50		
1DB-52-24WD	M52x2	G1.1/2"X11	38		22	23	55		

备注: 如需带卡套及卡套螺母整套订货, 则请在代号后加"RN", 如"1DB-22-08RN"

Remark: In case if you are interested to order the adapter in complete set with cutting ring and nut, it is necessary to insert suffix "RN" arter our part NO., for example 1DB-22-08RN.

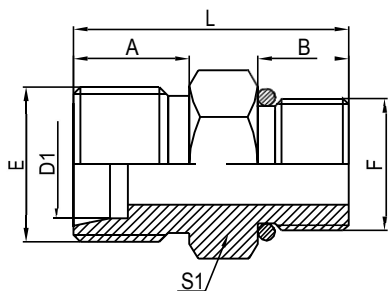

# 1CG

公制外螺纹24°轻系列/  
英管外螺纹O型圈密封  
METRIC MALE 24° L.T./  
BSP MALE O-RING

代号 PART NO.	螺纹 THREADE		管子外径 TUBE O.D.		尺寸 DIMENSIONS				
	E	F	D1		A	B	S1		L
1CG-12-02	M12x1.5	G1/8"X28	6		10	9	14		25
1CG-12-04	M12x1.5	G1/4"X19	6		10	12	14		28
1CG-14-04	M14x1.5	G1/4"X19	8		11	12	14		29
1CG-14-06	M14x1.5	G3/8"X19	8		11	13.5	22		32
1CG-14-08	M14x1.5	G1/2"X14	8		11	16	27		36
1CG-16-04	M16x1.5	G1/4"X19	10		11	12	19		29
1CG-16-06	M16x1.5	G3/8"X19	10		11	13.5	22		32
1CG-16-08	M16x1.5	G1/2"X14	10		11	16	27		36
1CG-18-06	M18x1.5	G3/8"X19	12		11.5	13.5	22		32
1CG-18-08	M18x1.5	G1/2"X14	12		11.5	16	27		36
1CG-22-06	M22x1.5	G3/8"X19	15		12.5	13.5	22		33
1CG-22-08	M22x1.5	G1/2"X14	15		12.5	16	27		37
1CG-22-12	M22x1.5	G3/4"X14	15		12.5	18.5	32		41
1CG-26-08	M26x1.5	G1/2"X14	18		12	16	27		37
1CG-26-12	M26x1.5	G3/4"X14	18		12	18.5	32		40.5
1CG-30-12	M30x2	G3/4"X14	22		14	18.5	32		42.5
1CG-30-16	M30x2	G1"X11	22		14	20.5	41		46.5
1CG-36-16	M36x2	G1"X11	28		16	20.5	41		48.5
1CG-45-20	M45x2	G1.1/4"X11	35		18	20.5	50		55
1CG-52-20	M52x2	G1.1/4"X11	42		19	20.5	55		56.5
1CG-52-24	M52x2	G1.1/2"X11	42		19	23	55		59
1CG-52-32	M52x2	G2"	42		19	25.5	70		62.5

备注:如需带卡套及卡套螺母整套订货,则请在代号后加"RN",如"1CG-22-08RN"

Remark: In case if you are interested to order the adapter in complete set with cutting ring and nut, it is necessary to insert suffix "RN" after our part NO., for example 1CG-22-08RN.

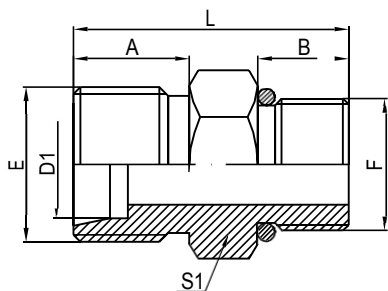

# 1DG

公制外螺纹24°重系列/  
英管外螺纹O型圈密封  
METRIC MALE 24° H.T./  
BSP MALE O-RING

代号 PART NO.	螺纹 THREADE		管子外径 TUBE O.D.		尺寸 DIMENSIONS				
	E	F	D1		A	B	S1		L
1DG-14-04	M14x1.5	G1/4"X19	6		12	12	19		30
1DG-16-04	M16x1.5	G1/4"X19	8		12	12	19		30
1DG-18-04	M18x1.5	G1/4"X19	10		12	12	19		30
1DG-18-06	M18x1.5	G3/8"X19	10		12	13.5	22		33
1DG-20-06	M20x1.5	G3/8"X19	12		12	13.5	22		33
1DG-20-08	M20x1.5	G1/2"X14	12		12	16	27		37
1DG-22-06	M22x1.5	G3/8"X19	14		14	13.5	24		35
1DG-22-08	M22x1.5	G1/2"X14	14		14	16	27		39
1DG-24-08	M24x1.5	G1/2"X14	16		14	16	27		39
1DG-30-12	M30x2	G3/4"X14	20		16	18.5	32		44.5
1DG-36-16	M36x2	G1"X11	25		18	20.5	41		51.5
1DG-42-16	M42x2	G1"X11	30		20	20.5	46		53.5
1DG-42-20	M42x2	G1.1/4"X11	30		20	20.5	50		57.5
1DG-52-24	M52x2	G1.1/2"X11	38		22	23	55		62

备注:如需带卡套及卡套螺母整套订货,则请在代号后加"RN",如"1DG-22-08RN"

Remark: In case if you are interested to order the adapter in complete set with cutting ring and nut, it is necessary to insert suffix "RN" arter our part NO., for example 1DG-22-08RN.

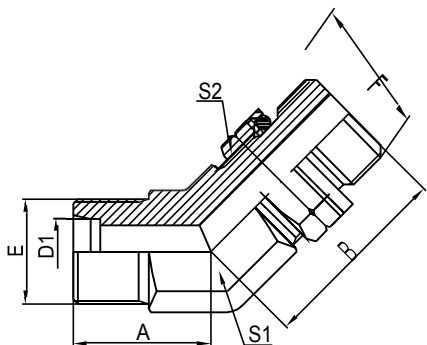

# 1CG4-OG

45° 英管螺纹 24° 轻系列可调向柱端  
45° BSP THREAD 24° L.T.ADJUSTABLE STUD.

代号 PART NO.	螺纹 THREADS		管子外径 TUBE O.D.		尺寸 DIMENSIONS				
	E	F	D1		A	B	S1	S2	
1CG4-12-02OG	M12x1.5	G1/8"X28	6		20	24	11	14	
1CG4-14-04OG	M14x1.5	G1/4"X19	8		22	27	14	19	
1CG4-16-04OG	M16x1.5	G1/4"X19	10		22	27	17	19	
1CG4-16-06OG	M16x1.5	G3/8"X19	10		22	30	17	22	
1CG4-18-06OG	M18x1.5	G3/8"X19	12		24	31	19	22	
1CG4-22-08OG	M22x1.5	G1/2"X14	15		27	36	22	27	
1CG4-26-08OG	M26x1.5	G1/2"X14	18		33	37.5	27	27	
1CG4-26-12OG	M26x1.5	G3/4"X14	18		33	42	27	32	
1CG4-30-12OG	M30x2	G3/4"X14	22		33	42.5	27	32	
1CG4-36-16OG	M36x2	G1"X11	28		37	44.5	33	41	
1CG4-45-20OG	M45x2	G1.1/4"X11	35		41	50.5	44	50	

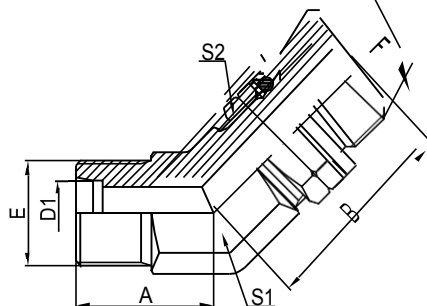

# 1DG4-OG

45° 英管螺纹 24° 重系列可调向柱端  
45° BSP THREAD 24° H.T.ADJUSTABLE STUD.

代号 PART NO.	螺纹 THREADS		管子外径 TUBE O.D.		尺寸 DIMENSIONS				
	E	F	D1		A	B	S1	S2	
1DG4-14-04OG	M14x1.5	G1/4"X19	6		22	27	14	19	
1DG4-16-04OG	M16x1.5	G1/4"X19	8		22	27	17	19	
1DG4-18-06OG	M18x1.5	G3/8"X19	10		24	31	19	22	
1DG4-20-06OG	M20x1.5	G3/8"X19	12		27	31	22	22	
1DG4-22-08OG	M22x1.5	G1/2"X14	14		27	36	22	27	
1DG4-30-12OG	M30x2	G3/4"X14	20		33	42.5	27	32	
1DG4-36-16OG	M36x2	G1"X11	25		37	44.5	33	41	
1DG4-42-20OG	M42x2	G1.1/4"X11	30		41	47.5	44	50	

备注:如需带卡套及卡套螺母整套订货,则请在代号后加"RN",如"1DG4-22-08OG/RN"(同上)  
Remark:In case if you are interested to order the adapter in complete set with cutting ring and nut, it is necessary to insert suffix"RN" after our part NO., for example 1DG4-22-08OG/RN. (the same with above)

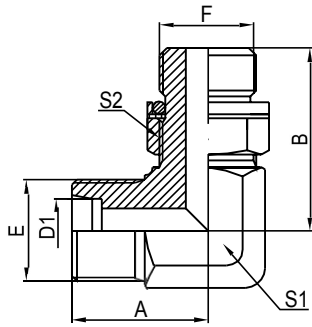

# 1CG9-OG

90° 英管螺纹24° 轻系列可调向柱端  
90° BSP THREAD 24° L.T.ADJUSTABLE STUD

代号 PART NO.	螺纹 THREADE		管子外径 TUBE O.D.		尺寸 DIMENSIONS				
	E	F	D1		A	B	S1	S2	
1CG9-12-02OG	M12x1.5	G1/8"X28	6		25	26.2	11	14	
1CG9-14-04OG	M14x1.5	G1/4"X19	8		29	31.3	14	19	
1CG9-16-04OG	M16x1.5	G1/4"X19	10		30	32.5	17	19	
1CG9-16-06OG	M16x1.5	G3/8"X19	10		30	35.8	17	22	
1CG9-18-06OG	M18x1.5	G3/8"X19	12		33	36.8	19	22	
1CG9-22-08OG	M22x1.5	G1/2"X14	15		37	43.2	22	27	
1CG9-26-08OG	M26x1.5	G1/2"X14	18		41	46	27	27	
1CG9-30-12OG	M30x2	G3/4"X14	22		40	52	27	32	
1CG9-36-16OG	M36x2	G1"X11	28		46	56	33	41	
1CG9-45-20OG	M45x2	G1.1/4"X11	35		55	63	44	50	
1CG9-52-24OG	M52x2	G1.1/2"X11	42		59	68.5	55	55	

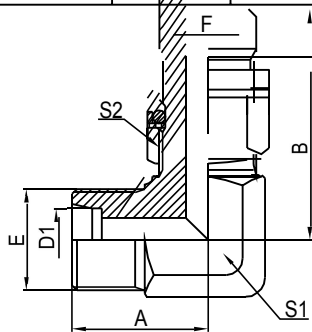

# 1DG9-OG

90° 英管螺纹24° 重系列可调向柱端  
90° BSP THREAD 24° H.T.ADJUSTABLE STUD

代号 PART NO.	螺纹 THREADE		管子外径 TUBE O.D.		尺寸 DIMENSIONS				
	E	F	D1		A	B	S1	S2	
1DG9-14-04OG	M14x1.5	G1/4"X19	6		29	31.3	14	19	
1DG9-16-04OG	M16x1.5	G1/4"X19	8		30	32.5	17	19	
1DG9-18-06OG	M18x1.5	G3/8"X19	10		33	36.8	19	22	
1DG9-20-06OG	M20x1.5	G3/8"X19	12		37	36.8	22	22	
1DG9-22-08OG	M22x1.5	G1/2"X14	14		37	43.2	22	27	
1DG9-30-12OG	M30x2	G3/4"X14	20		40	52	27	32	
1DG9-36-16OG	M36x2	G1"X11	25		46	56	33	41	
1DG9-42-20OG	M42x2	G1.1/4"X11	30		55	58	44	50	

备注:如需带卡套及卡套螺母整套订货,则请在代号后加"RN",如"1DG9-22-08OG/RN"(同上)

Remark:In case if you are interested to order the adapter in complete set with cutting ring and nut,it is necessary to insert suffix"RN" arter our part NO.,for example 1DG9-22-08OG/RN. (the same with above)

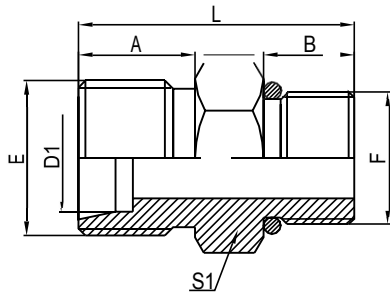

# 1CH

公制外螺纹24°轻系列/六角端面O型圈密封METRIC  
 MALE 24° L.T./METRIC  
 MALE WITH O-RING

代号 PART NO.	螺纹 THREADS		管子外径 TUBE O.D.		尺寸 DIMENSIONS				
	E	F	D1		A	B	S1		L
1CH-12-10	M12x1.5	M10x1	6		10	8.5	12		24.5
1CH-14	M14x1.5	M14x1.5	8		11	11	19		28
1CH-14-12	M14x1.5	M12x1.5	8		11	11	17		28
1CH-16-14	M16x1.5	M14x1.5	10		11	11	19		28
1CH-18-14	M18x1.5	M14x1.5	12		11.5	11	19		28.5
1CH-14-18	M14x1.5	M18x1.5	8		11	11	24		30
1CH-16	M16x1.5	M16x1.5	10		11	11	22		29
1CH-16-18	M16x1.5	M18x1.5	10		11	11	24		30
1CH-18-16	M18x1.5	M16x1.5	12		11.5	11	22		30
1CH-22-16	M22x1.5	M16x1.5	12		12.5	11	24		31
1CH-22-18	M22x1.5	M18x1.5	15		12.5	11	24		31
1CH-16-22	M16x1.5	M22x1.5	10		11	12	27		32
1CH-22-20	M22x1.5	M20x1.5	15		12.5	12	27		33
1CH-22	M22x1.5	M22x1.5	12		12.5	12	27		33
1CH-26-22	M26x1.5	M22x1.5	18		12	12	27		33
1CH-26	M26x1.5	M26x1.5	18		12	13	32		35
1CH-26-27	M26x1.5	M27x2	18		12	13	32		35
1CH-30-22	M30x2	M22x1.5	22		14	12	32		36
1CH-30-27	M30x2	M27x2	22		14	13	32		37
1CH-30	M30x2	M30x2	22		14	14	36		39
1CH-36-27	M36x2	M27x2	28		16	13	36		40

备注:如需带卡套及卡套螺母整套订货,则请在代号后加"RN",如"1CH-22-08RN"

Remark: In case if you are interested to order the adapter in complete set with cutting ring and nut, it is necessary to insert suffix "RN" after our part NO., for example 1CH-22-08RN.



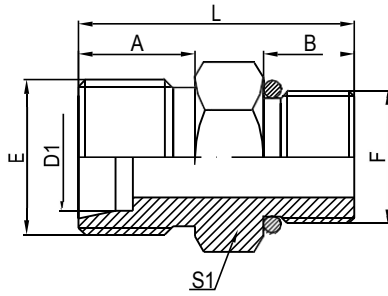

# 1DH

公制外螺纹24°重系列/  
外螺纹六角端面O型圈密封  
METRIC MALE 24° H.T./  
METRIC MALE WITH O-RING

代号 PART NO.	螺纹 THREADE		管子外径 TUBE O.D.		尺寸 DIMENSIONS				
	E	F	D1		A	B	S1		L
1DH-14	M14x1.5	M14x1.5	6		12	11	19		29
1DH-14-12	M14x1.5	M12x1.5	6		12	11	17		29
1DH-16-14	M16x1.5	M14x1.5	8		12	11	19		29
1DH-18-16	M18x1.5	M16x1.5	10		12	11	22		30
1DH-20-14	M20x1.5	M14x1.5	12		12	11	22		30
1DH-20-16	M20x1.5	M16x1.5	12		12	11	22		30
1DH-20-18	M20x1.5	M18x1.5	12		12	11	24		31
1DH-20-22	M20x1.5	M22x1.5	12		12	12	27		33
1DH-24-22	M24x1.5	M22x1.5	16		14	12	27		35
1DH-30	M30x2	M30x2	20		16	14	36		41
1DH-30-27	M30x2	M27x2	20		16	13	32		39
1DH-36-27	M36x2	M27x2	25		18	13	36		42

备注:如需带卡套及卡套螺母整套订货,则请在代号后加"RN",如"1DH-22-08RN"

Remark: In case if you are interested to order the adapter in complete set with cutting ring and nut, it is necessary to insert suffix "RN" arter our part NO., for example 1DH-22-08RN.

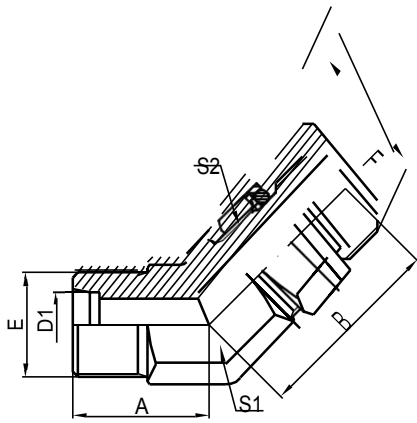

# 1CH4-OG

45° 公制外螺纹24° 轻系列可调向柱端  
45° METRIC MALE 24° L.T.ADJUSTABLE STUD

代号 PART NO.	螺纹 THREADE		管子外径 TUBE O.D.		尺寸 DIMENSIONS				
	E	F	D1		A	B	S1	S2	
1CH4-12-10OG	M12x1.5	M10x1	6		20	25.5	11	14	
1CH4-14-12OG	M14x1.5	M12x1.5	8		22	30	14	17	
1CH4-16-14OG	M16x1.5	M14x1.5	10		22	30.5	17	19	
1CH4-18-16OG	M18x1.5	M16x1.5	12		24	34	19	22	
1CH4-22-18OG	M22x1.5	M18x1.5	15		27	38	22	24	
1CH4-26-22OG	M26x1.5	M22x1.5	18		33	40.5	27	27	
1CH4-30-27OG	M30x2	M27x2	25		33	48	27	32	
1CH4-36-33OG	M36x2	M33x2	28		37	49.5	33	41	
1CH4-45-42OG	M45x2	M42x2	35		41	55	44	50	

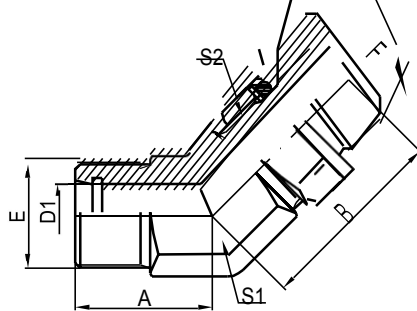

# 1DH4-OG

45° 公制外螺纹24° 重系列可调向柱端  
45° METRIC MALE 24° H.T.ADJUSTABLE STUD

代号 PART NO.	螺纹 THREADE		管子外径 TUBE O.D.		尺寸 DIMENSIONS				
	E	F	D1		A	B	S1	S2	
1DH4-14-12OG	M14x1.5	M12x1.5	6		22	30	14	17	
1DH4-16-14OG	M16x1.5	M14x1.5	8		22	30.5	17	19	
1DH4-18-16OG	M18x1.5	M16x1.5	10		24	34	19	22	
1DH4-20-18OG	M20x1.5	M18x1.5	12		27	37	22	24	
1DH4-24-22OG	M24x1.5	M22x1.5	16		33	40	27	27	
1DH4-30-27OG	M30x2	M27x2	20		33	48	27	32	
1DH4-36-33OG	M36x2	M33x2	25		37	49.5	33	41	
1DH4-42-42OG	M42x2	M42x2	30		41	54	44	50	

备注:如需带卡套及卡套螺母整套订货,则请在代号后加"RN",如"1DH4-24-22OG/RN"(同上)  
Remark:In case if you are interested to order the adapter in complete set with cutting ring and nut,it is necessary to insert suffix"RN" arter our part NO.,for example 1DH4-24-22OG/RN. (the same with above)

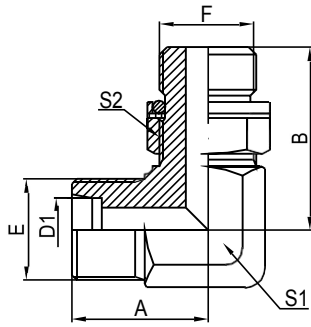

# 1CH9-OG

90° 公制外螺纹24° 轻系列可调向柱端  
90° METRIC MALE 24° L.T. ADJUSTABLE STUD

代号 PART NO.	螺纹 THREADE		管子外径 TUBE O.D.		尺寸 DIMENSIONS				
	E	F	D1		A	B	S1	S2	
1CH9-12-100G	M12x1.5	M10x1	6		25	26.5	11	14	
1CH9-14-120G	M14x1.5	M12x1.5	8		29	32	14	17	
1CH9-16-140G	M16x1.5	M14x1.5	10		30	34	17	19	
1CH9-18-160G	M18x1.5	M16x1.5	12		33	36	19	22	
1CH9-22-180G	M22x1.5	M18x1.5	15		37	39.5	22	24	
1CH9-26-220G	M26x1.5	M22x1.5	18		41	43.5	27	27	
1CH9-30-270G	M30x2	M27x2	25		40	50	27	32	
1CH9-36-330G	M36x2	M33x2	28		46	54	33	41	

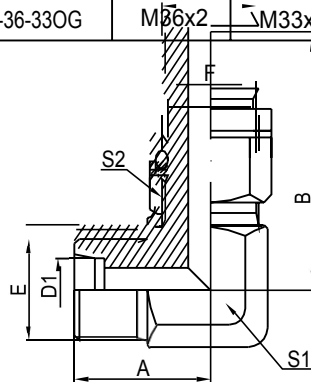

# 1DH9-OG

90° 公制外螺纹24° 重系列可调向柱端  
90° METRIC MALE 24° H.T. ADJUSTABLE STUD

代号 PART NO.	螺纹 THREADE		管子外径 TUBE O.D.		尺寸 DIMENSIONS				
	E	F	D1		A	B	S1	S2	
1DH9-14-120G	M14x1.5	M12x1.5	6		29	32	14	17	
1DH9-16-140G	M16x1.5	M14x1.5	8		30	34	17	19	
1DH9-18-160G	M18x1.5	M16x1.5	10		33	36	19	22	
1DH9-20-180G	M20x1.5	M18x1.5	12		37	37	22	24	
1DH9-22-200G	M22x1.5	M20x1.5	14		37	40	22	27	
1DH9-24-220G	M24x1.5	M22x1.5	16		37	37.5	24	27	
1DH9-30-270G	M30x2	M27x2	20		41	50	27	32	
1DH9-36-330G	M36x2	M33x2	25		46	54	33	41	
1DH9-420G	M42x2	M42x2	30		55	57.2	44	50	

备注:如需带卡套及卡套螺母整套订货,则请在代号后加"RN",如"1CB-22-08RN"(同上)  
Remark:In case if you are interested to order the adapter in complete set with cutting ring and nut, it is necessary to insert suffix"RN" arter our part NO., for example 1CB-22-08RN. (the same with above)

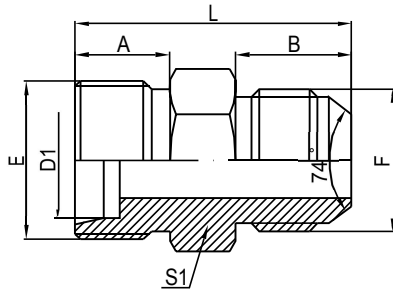

# 1CJ

公制外螺纹24°轻系列  
/美制JIC74°锥密封  
METRIC MALE 24° L.T./  
JIC 74° CONE SEAL

代号 PART NO.	螺纹 THREADE		管子外径 TUBE O.D.		尺寸 DIMENSIONS				
	E	F	D1		A	B	S1		L
1CJ-12-04	M12x1.5	U7/16"X20	6		10	14	14		30
1CJ-14-04	M14x1.5	U7/16"X20	8		11	14	14		31
1CJ-14-06	M14x1.5	U9/16"X18	8		11	14	17		31
1CJ-16-06	M16x1.5	U9/16"X18	10		11	14	17		31
1CJ-18-06	M18x1.5	U9/16"X18	12		11.5	14	19		31.5
1CJ-18-08	M18x1.5	U3/4"X16	12		11.5	16.7	22		35
1CJ-22-08	M22x1.5	U3/4"X16	15		12.5	16.7	24		37
1CJ-22-10	M22x1.5	U7/8"X14	15		12.5	19.5	24		40
1CJ-26-10	M26x1.5	U7/8"X14	18		12	19.5	27		40
1CJ-26-12	M26x1.5	U1.1/16"X12	18		12	19.5	30		41.5
1CJ-30-12	M30x2	U1.1/16"X12	22		14	22	32		46
1CJ-36-16	M36x2	U1.5/16"X12	28		16	23	36		50
1CJ-45-20	M45x2	U1.5/8"X12	35		18	24.5	46		55.5
1CJ-52-20	M52x2	U1.5/8"X12	42		19	24.5	55		60.5
1CJ-52-24	M52x2	U1.7/8"X12	42		19	27.5	55		63.5

备注:如需带卡套及卡套螺母整套订货,则请在代号后加"RN",如"1CJ-22-08RN"

Remark: In case if you are interested to order the adapter in complete set with cutting ring and nut, it is necessary to insert suffix "RN" arter our part NO., for example 1CJ-22-08RN.

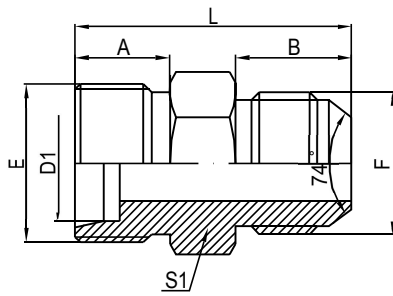

# 1DJ

公制外螺纹24°重系列  
/美制JIC74°锥密封  
METRIC MALE 24° H.T./  
JIC 74° CONE SEAL

代号 PART NO.	螺纹 THREADS		管子外径 TUBE O.D.		尺寸 DIMENSIONS				
	E	F	D1		A	B	S1		L
1DJ-14-04	M14x1.5	U7/16"X20	6		12	14	14		32
1DJ-16-04	M16x1.5	U7/16"X20	8		12	14	17		32
1DJ-16-06	M16x1.5	U9/16"X18	8		12	14	17		32
1DJ-18-04	M18x1.5	U7/16"X20	10		12	14	19		32
1DJ-18-06	M18x1.5	U9/16"X18	10		12	14	19		32
1DJ-20-06	M20x1.5	U9/16"X18	12		12	14	22		33
1DJ-20-08	M20x1.5	U3/4"X16	12		12	16.7	22		36
1DJ-22-08	M22x1.5	U3/4"X16	14		14	16.7	24		38
1DJ-24-08	M24x1.5	U3/4"X16	16		14	16.7	27		39
1DJ-24-10	M24x1.5	U7/8"X14	16		14	19.5	30		42.5
1DJ-30-12	M30x2	U1.1/16"X12	20		16	22	32		48
1DJ-36-16	M36x2	U1.5/16"X12	25		18	23	32		52
1DJ-42-20	M42x2	U1.5/8"X12	30		20	24.5	46		57.5
1DJ-52-24	M52x2	U1.7/8"X12	38		22	27.5	55		66.5

备注: 如需带卡套及卡套螺母整套订货, 则请在代号后加"RN", 如"1DJ-22-08RN"

Remark: In case if you are interested to order the adapter in complete set with cutting ring and nut, it is necessary to insert suffix "RN" after our part NO., for example 1DJ-22-08RN.

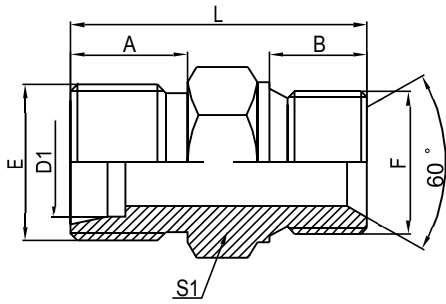

# 1CM

公制外螺纹24°轻系列  
/ 60°内锥面或组合垫密封  
METRIC MALE 24° L.T.  
/60° CONE BONDED SEAL

代号 PART NO.	螺纹 THREADE		管子外径 TUBE O.D.		尺寸 DIMENSIONS				
	E	F	D1		A	B	S1		L
1CM-14-12	M14x1.5	M12x1.5	8		11	10	17		29
1CM-14-18	M14x1.5	M18x1.5	8		11	12	24		33
1CM-16-14	M16x1.5	M14x1.5	10		11	11	19		30
1CM-16-16	M16x1.5	M16x1.5	10		11	12	22		32
1CM-16-18	M16x1.5	M18x1.5	10		11	12	24		33
1CM-16-22	M16x1.5	M22x1.5	10		11	14	27		36
1CM-18-14	M18x1.5	M14x1.5	12		11.5	11	19		30.5
1CM-18-16	M18x1.5	M16x1.5	12		11.5	12	22		33
1CM-18-18	M18x1.5	M18x1.5	12		11.5	12	24		33
1CM-18-22	M18x1.5	M22x1.5	12		11.5	14	27		36
1CM-22-16	M22x1.5	M16x1.5	15		12.5	12	22		34
1CM-22-18	M22x1.5	M18x1.5	15		12.5	12	24		34
1CM-22	M22x1.5	M22x1.5	15		12.5	14	27		37
1CM-26-18	M26x1.5	M18x1.5	18		12	12	24		34
1CM-26-22	M26x1.5	M22x1.5	18		12	14	27		37
1CM-30-22	M30x2	M22x1.5	22		14	14	30		39
1CM-36-33	M36x2	M33x2	28		16	18	41		49

备注:如需带卡套及卡套螺母整套订货,则请在代号后加"RN",如"1CM-18-16RN"

Remark: In case if you are interested to order the adapter in complete set with cutting ring and nut, it is necessary to insert suffix "RN" arter our part NO., for example 1CM-18-16RN.

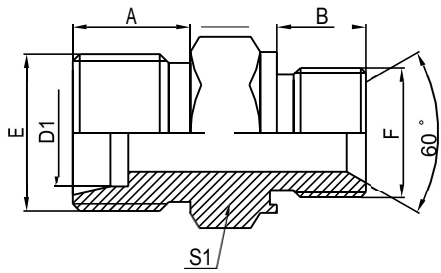

# 1CM-WD

公制外螺纹24°轻系列  
/ 60°内锥面或胶垫密封  
METRIC MALE 24° L.T. /  
60° CONE CAPTIVE SEAL

代号 PART NO.	螺纹 THREADS		管子外径 TUBE O.D.		尺寸 DIMENSIONS				
	E	F	D1		A	B	S1		
1CM-14-12WD	M14x1.5	M12x1.5	8		11	10	17		
1CM-16-12WD	M16x1.5	M12x1.5	10		11	10	17		
1CM-16-14WD	M16x1.5	M14x1.5	10		11	11	19		
1CM-16-18WD	M16x1.5	M18x1.5	10		11	12	24		
1CM-18-16WD	M18x1.5	M16x1.5	12		11.5	12	22		
1CM-18WD	M18x1.5	M18x1.5	12		11.5	12	24		
1CM-18-22WD	M18x1.5	M22x1.5	12		11.5	14	27		
1CM-22-18WD	M22x1.5	M18x1.5	15		12.5	12	24		
1CM-22WD	M22x1.5	M22x1.5	15		12.5	14	27		
1CM-26-22WD	M26x1.5	M22x1.5	18		12	14	27		

备注:如需带卡套及卡套螺母整套订货,则请在代号后加"RN",如"1CM-18-16WD/RN"

Remark: In case if you are interested to order the adapter in complete set with cutting ring and nut, it is necessary to insert suffix "RN" after our part NO., for example 1CM-18-16WD/RN.

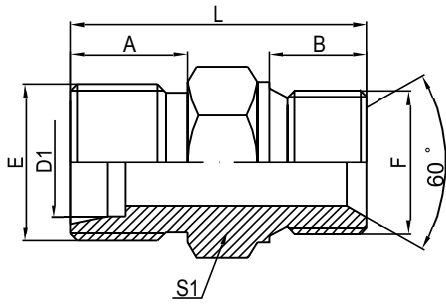

# 1DM

公制外螺纹24°重系列  
/ 60°内锥面或组合垫密封  
METRIC MALE 24° H.T. /  
60° CONE BONDED SEAL

代号 PART NO.	螺纹 THREADE		管子外径 TUBE O.D.		尺寸 DIMENSIONS				
	E	F	D1		A	B	S1		L
1DM-14-12	M14x1.5	M12x1.5	6		12	10	17		30
1DM-16-14	M16x1.5	M14x1.5	8		12	11	19		31
1DM-18-16	M18x1.5	M16x1.5	10		12	12	22		33
1DM-20-18	M20x1.5	M18x1.5	12		12	12	24		34
1DM-20-22	M20x1.5	M22x1.5	12		12	14	27		37
1DM-24-18	M24x1.5	M18x1.5	16		14	12	27		37
1DM-24-22	M24x1.5	M22x1.5	16		14	14	27		39

备注:如需带卡套及卡套螺母整套订货,则请在代号后加"RN",如"1DM-20-22RN"

Remark: In case if you are interested to order the adapter in complete set with cutting ring and nut, it is necessary to insert suffix "RN" arter our part NO., for example 1DM-20-22RN.

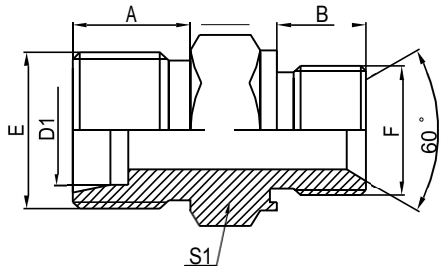

# 1DM-WD

公制外螺纹24°重系列  
/ 60°内锥面或胶垫密封  
METRIC MALE 24° H.T. /  
60° CONE CAPTIVE SEAL

代号 PART NO.	螺纹 THREADE		管子外径 TUBE O.D.		尺寸 DIMENSIONS				
	E	F	D1		A	B	S1		
1DM-14-12WD	M14x1.5	M12x1.5	6		12	10	17		
1DM-16-14WD	M16x1.5	M14x1.5	8		12	11	19		
1DM-18-16WD	M18x1.5	M16x1.5	10		12	12	22		
1DM-20-18WD	M20x1.5	M18x1.5	12		12	12	24		
1DM-24-22WD	M24x1.5	M22x1.5	14		14	14	27		

备注:如需带卡套及卡套螺母整套订货,则请在代号后加"RN",如"1DM-20-18WD/RN"

Remark: In case if you are interested to order the adapter in complete set with cutting ring and nut, it is necessary to insert suffix "RN" arter our part NO., for example 1DM-20-18WD/RN.



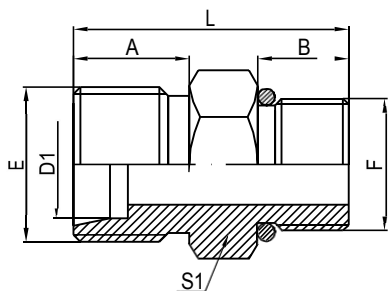

# 1CO

公制外螺纹24°轻系列  
/美制外螺纹O型圈密封  
METRIC MALE 24° L.T./  
SAE MALE O-RING

代号 PART NO.	螺纹 THREADE		管子外径 TUBE O.D.		尺寸 DIMENSIONS				
	E	F	D1		A	B	S1		L
1CO-14-04	M14x1.5	U7/16"X20	8		11	10	14		27
1CO-16-04	M16x1.5	U7/16"X20	10		11	10	17		27
1CO-18-06	M18x1.5	U9/16"X18	12		11.5	12	19		29.5
1CO-18-08	M18x1.5	U3/4"X16	12		11.5	12	24		31
1CO-18-10	M18x1.5	U7/8"X14	12		11.5	13.5	27		34
1CO-22-08	M22x1.5	U3/4"X16	15		12.5	12	24		32
1CO-22-10	M22x1.5	U7/8"X14	15		12.5	13.5	27		35
1CO-22-12	M22x1.5	U1.1/16"X12	15		12.5	16	32		38.5
1CO-26-08	M26x1.5	U3/4"X16	18		12	12	27		33
1CO-26-10	M26x1.5	U7/8"X14	18		12	13.5	27		34
1CO-30-08	M30x2	U3/4"X16	22		14	12	32		36
1CO-30-10	M30x2	U7/8"X14	22		14	13.5	32		37.5
1CO-30-12	M30x2	U1.1/16"X12	22		14	16	32		40
1CO-30-16	M30x2	U1.5/16"X12	22		14	17	41		43
1CO-36-16	M36x2	U1.5/16"X12	28		16	17	41		45
1CO-45-16	M45x2	U1.5/16"X12	35		18	17	46		48
1CO-45-20	M45x2	U1.5/8"X12	35		18	18	50		53
1CO-52-20	M45x2	U1.5/8"X12	42		19	18	55		54

备注:如需带卡套及卡套螺母整套订货,则请在代号后加"RN",如"1CO-22-08RN"

Remark: In case if you are interested to order the adapter in complete set with cutting ring and nut, it is necessary to insert suffix "RN" arter our part NO., for example 1CO-22-08RN.

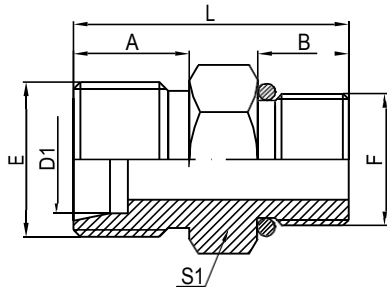

# 1DO

公制外螺纹24°重系列  
/美制外螺纹O型圈密封  
METRIC MALE 24° H.T./  
SAE MALE O-RING

代号 PART NO.	螺纹 THREADE		管子外径 TUBE O.D.		尺寸 DIMENSIONS				
	E	F	D1		A	B	S1		L
1DO-16-04	M16x1.5	U7/16"X20	8		12	10	17		28
1DO-18-06	M18x1.5	U9/16"X18	10		12	12	19		30
1DO-20-06	M20x1.5	U9/16"X18	12		12	12	22		31
1DO-20-08	M20x1.5	U3/4"X16	12		12	12	24		32
1DO-24-08	M24x1.5	U3/4"X16	16		14	12	24		34
1DO-24-10	M24x1.5	U7/8"X14	16		14	13.5	27		36
1DO-30-08	M30x2	U3/4"X16	20		16	12	32		38
1DO-30-10	M30x2	U7/8"X14	20		16	13.5	32		39.5
1DO-30-12	M30x2	U1.1/16"X12	20		16	16	32		42
1DO-36-16	M36x2	U1.5/16"X12	25		18	17	41		47
1DO-42-16	M42x2	U1.5/16"X12	30		20	17	46		50
1DO-42-20	M42x2	U1.5/8"X12	30		20	18	50		55
1DO-52-20	M52x2	U1.5/8"X12	38		22	18	55		57

备注:如需带卡套及卡套螺母整套订货,则请在代号后加"RN",如"1DO-24-08RN"

Remark: In case if you are interested to order the adapter in complete set with cutting ring and nut, it is necessary to insert suffix "RN" arter our part NO., for example 1DO-24-08RN.

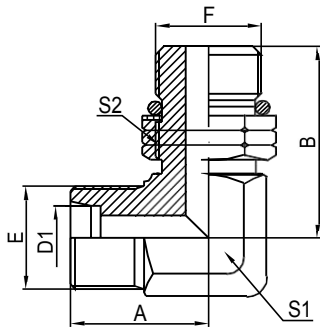

# 1C09-OG

90° 公制外螺纹24° 轻系列  
 /美制外螺纹可调向柱端  
 90° METRIC 24° L.T.  
 /SAE MALE ADJUSTABLE STUD

代号 PART NO.	螺纹 THREADE		管子外径 TUBE O.D.		尺寸 DIMENSIONS				
	E	F	D1		A	B	S1	S2	
1C09-12-04OG	M12x1.5	U7 / 16"X20	6		25	27.2	11	17	
1C09-14-06OG	M14x1.5	U9 / 16"X18	8		29	31.8	14	19	
1C09-16-06OG	M16x1.5	U9 / 16"X18	10		30	33.3	17	19	
1C09-18-08OG	M18x1.5	U3 / 4"X16	12		33	37.5	19	24	
1C09-22-08OG	M22x1.5	U3 / 4"X16	15		37	44	22	27	
1C09-22-10OG	M22x1.5	U7 / 8"X14	15		37	39.5	22	24	
1C09-26-12OG	M26x1.5	U1.1 / 16"X12	18		41	51	27	32	
1C09-30-12OG	M30x2	U1.1 / 16"X12	22		41	53.5	27	32	
1C09-36-16OG	M36x2	U1.5 / 16"X12	28		49	57.5	33	41	
1C09-45-20OG	M45x2	U1.5 / 8"X12	35		55	63	44	50	
1C09-52-24OG	M52x2	U1.7 / 8"X12	42		59	70.5	55	55	

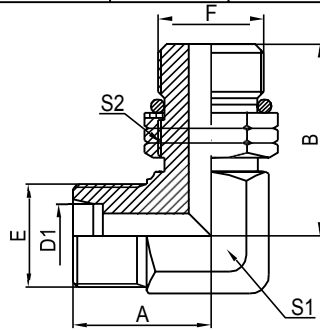

# 1D09-OG

90° 公制外螺纹24° 重系列  
 /美制外螺纹可调向柱端  
 90° METRIC 24° H.T.  
 /SAE MALE ADJUSTABLE STUD

代号 PART NO.	螺纹 THREADE		管子外径 TUBE O.D.		尺寸 DIMENSIONS				
	E	F	D1		A	B	S1	S2	
1D09-14-04OG	M14x1.5	U7/16"X20	6		29	30	14	17	
1D09-16-06OG	M16x1.5	U9/16"X18	8		30	33.3	17	19	
1D09-18-06OG	M18x1.5	U9/16"X18	10		33	33.5	19	19	
1D09-20-08OG	M20x1.5	U3/4"X16	12		37	37.5	22	24	
1D09-24-10OG	M24x1.5	U7/8"X14	16		37	46.5	24	27	
1D09-30-12OG	M30x2	U1.1 / 16"X12	20		41	53.5	27	32	
1D09-36-16OG	M36x2	U1.5 / 16"X12	25		49	57.5	33	41	
1D09-42-20OG	M42x2	U1.5 / 8"X12	30		57	59.5	44	50	

备注:如需带卡套及卡套螺母整套订货,则请在代号后加"RN",如"1D09-20-08RN"(同上)  
 Remark:In case if you are interested to order the adapter in complete set with cutting ring and nut,it is necessary to insert suffix"RN" arter our part NO.,for example 1D09-20-08RN. (the same with above)

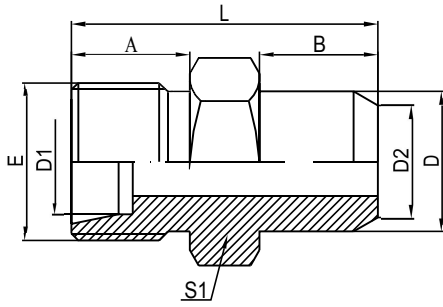

# 1CW

公制外螺纹24°轻系列/ 焊接接头  
METRIC MALE 24° L.T./WELD FITTINGS

代号 PART NO.	螺纹 THREADE		管子外径 TUBE O.D.		尺寸 DIMENSIONS				
	E		D1	D2	A	B	D	S1	L
1CW-12-06	M12x1.5		6	6	10	7	10	12	23
1CW-14-08	M12x1.5		8	8	11	8	12	14	25
1CW-16-10	M16x1.5		10	10	11	8	14	17	25
1CW-18-12	M18x1.5		12	12	11.5	8	16	19	25.5
1CW-22-15	M22x1.5		15	15	12.5	10	19	22	30
1CW-26-22	M26x1.5		18	22	12	10	27	27	32
1CW-30-22	M30x2		22	22	14	12	27	32	37
1CW-30-25	M30x2		22	25	14	12	31	32	37
1CW-36-28	M36x2		28	28	16	12	32	36	39
1CW-45-35	M45x2		35	35	18	14	40	46	45
1CW-52-42	M52x2		42	42	19	16	46	55	52

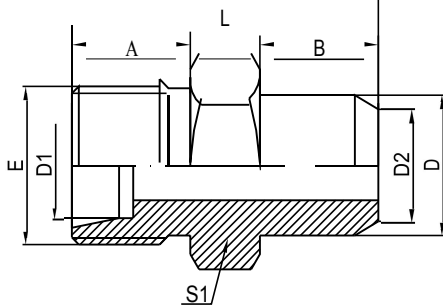

# 1DW

公制外螺纹24°重系列/ 焊接接头  
METRIC MALE 24° H.T./WELD FITTINGS

代号 PART NO.	螺纹 THREADE		管子外径 TUBE O.D.		尺寸 DIMENSIONS				
	E		D1	D2	A	B	D	S1	L
1DW-14-06	M14x1.5		6	6	12	7	11	14	25
1DW-16-08	M16x1.5		8	8	12	8	13	17	26
1DW-18-10	M18x1.5		10	10	12	8	15	19	26
1DW-20-12	M20x1.5		12	12	12	10	17	22	29
1DW-24-16	M24x1.5		16	16	14	10	21	27	33
1DW-30-20	M30x2		20	20	16	12	26	32	38
1DW-36-25	M36x2		25	25	18	12	31	41	42
1DW-42-30	M42x2		30	30	20	14	36	46	47
1DW-52-38	M52x2		38	38	22	16	44	55	55

备注:如需带卡套及卡套螺母整套订货,则请在代号后加"RN",如"1DW-20-12RN"(同上)  
Remark: In case if you are interested to order the adapter in complete set with cutting ring and nut, it is necessary to insert suffix "RN" arter our part NO., for example 1DW-20-12RN. (the same with above)

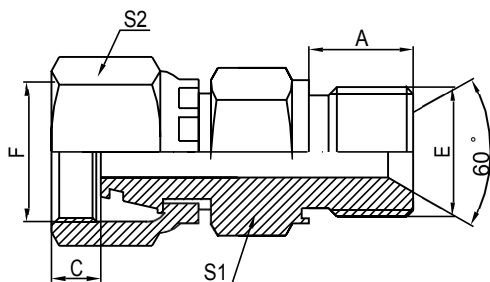

## 2BC-WD

公制螺纹24°轻系列/ 英管螺纹  
60°锥面组合垫密封  
METRIC FEMALE 24° L.T./BSP MALE  
DOUBLE 60° SEAT BONDED SEAL

代号 PART NO.	螺纹 THREADE		管子外径 TUBE O.D.		尺寸 DIMENSIONS				
	E	F	D1		A	C	S1	S2	
2BC-02-12WD	G1/8"X28	M12x1.5	6		10	2	14	17	
2BC-04-14WD	G1/4"X19	M14x1.5	8		12	3.5	19	19	
2BC-04-16WD	G1/4"X19	M16x1.5	10		12	3.5	19	22	
2BC-06-18WD	G3/8"X19	M18x1.5	12		13.5	3.5	22	24	
2BC-08-22WD	G1/2"X14	M22x1.5	15		16	3	27	27	
2BC-08-26WD	G1/2"X14	M26x1.5	18		16	3.5	27	32	
2BC-12-30WD	G3/4"X14	M30x2	22		18.5	4.5	32	36	
2BC-16-36WD	G1"X11	M36x2	28		20.5	4.5	41	41	
2BC-20-45WD	G1.1/4"X11	M45x2	35		20.5	5.5	50	55	
2BC-24-52WD	G1.1/2"X11	M52x2	42		23	6.5	55	60	

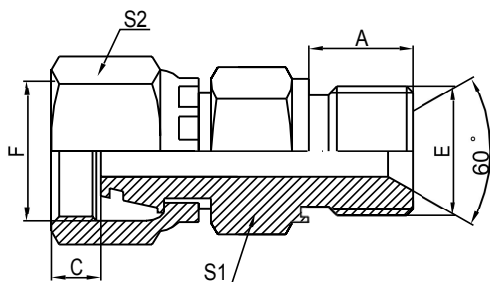

## 2BD-WD

公制螺纹24°重系列/ 英管螺纹  
60°锥面组合垫密封  
METRIC FEMALE 24° H.T./BSP MALE  
DOUBLE 60° SEAT BONDED SEAL

代号 PART NO.	螺纹 THREADE		管子外径 TUBE O.D.		尺寸 DIMENSIONS				
	E	F	D1		A	C	S1	S2	
2BD-04-14WD	G1/4"X19	M14x1.5	6		12	3	19	19	
2BD-04-16WD	G1/4"X19	M16x1.5	8		12	3.5	19	22	
2BD-06-18WD	G3/8"X19	M18x1.5	10		13.5	3	22	24	
2BD-06-20WD	G3/8"X19	M20x1.5	12		13.5	3	22	27	
2BD-08-22WD	G1/2"X14	M22x1.5	14		16	2.5	27	27	
2BD-08-24WD	G1/2"X14	M24x1.5	16		16	3.5	27	30	
2BD-12-30WD	G3/4"X14	M30x2	20		18.5	4.5	32	36	
2BD-16-36WD	G1"X11	M36x2	25		20.5	3.5	41	41	
2BD-20-42WD	G1.1/4"X11	M42x2	30		20.5	5.5	50	50	
2BD-24-52WD	G1.1/2"X11	M52x2	38		23	7	55	60	

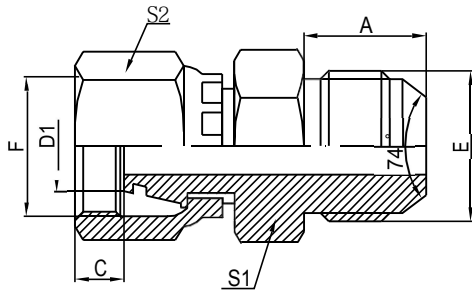

# 2JC

美制JIC 74° 锥密封/公制内螺  
纹24° 锥O型圈密封轻系列  
JIC 74° CONE SEALING/METRIC  
FEMALE 24° CONE O-RING SEALING L.T.

代号 PART NO.	螺纹 THREADS		管子外径 TUBE O.D.		尺寸 DIMENSIONS				
	E	F	D1		A	C	S1	S2	
2JC-04-12	U7/16"X20	M12x1.5	6		14	2	14	17	
2JC-04-14	U7/16"X20	M14x1.5	8		14	3.5	14	19	
2JC-05-14	U1/2"X20	M14x1.5	8		14	3.5	14	19	
2JC-05-16	U1/2"X20	M16x1.5	10		14	3.5	17	22	
2JC-06-14	U9/16"X18	M14x1.5	8		14	3.5	17	19	
2JC-06-16	U9/16"X18	M16x1.5	10		14	3.5	17	22	
2JC-06-18	U9/16"X18	M18x1.5	12		14	3.5	17	24	
2JC-08-18	U3/4"X16	M18x1.5	12		16.7	3.5	22	24	
2JC-08-22	U3/4"X16	M22x1.5	15		16.7	3	22	27	
2JC-10-22	U7/8"X14	M22x1.5	15		19.5	3	24	27	
2JC-10-26	U7/8"X14	M26x1.5	18		19.5	3.5	27	32	
2JC-12-26	U1.1/16"X12	M26x1.5	18		22	3.5	27	32	
2JC-12-30	U1.1/16"X12	M30x2	22		22	4.5	30	36	
2JC-16-36	U1.5/16"X12	M36x2	28		23	4.5	36	41	
2JC-16-45	U1.5/16"X12	M45x2	35		23	5.5	46	55	
2JC-20-45	U1.5/8"X12	M45x2	35		24.5	5.5	46	55	
2JC-20-52	U1.5/8"X12	M52x2	42		24.5	6.5	50	60	
2JC-24-52	U1.7/8"X12	M52x2	42		27.5	6.5	50	60	

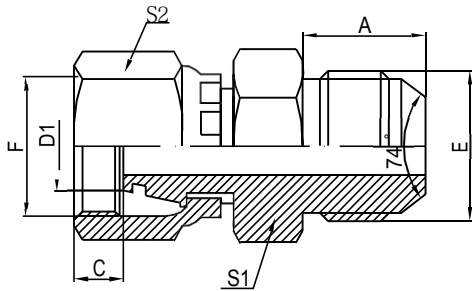

# 2JD

美制JIC 74° 锥密封/公制内螺  
纹24° 锥O型圈密封重系列  
JIC 74° CONE SEALING/METRIC  
FEMALE 24° CONE O-RING SEALING H.T.

代号 PART NO.	螺纹 THREADE		管子外径 TUBE O.D.		尺寸 DIMENSIONS				
	E	F	D1		A	C	S1	S2	
2JD-04-14	U7/16"X20	M14x1.5	6		14	3	14	19	
2JD-04-16	U7/16"X20	M16x1.5	8		14	3.5	17	22	
2JD-04-18	U7/16"X20	M18x1.5	10		14	3	17	24	
2JD-05-18	U1/2"X20	M18x1.5	10		14	3	17	24	
2JD-06-16	U9/16"X18	M16x1.5	8		14	3.5	17	22	
2JD-06-18	U9/16"X18	M18x1.5	10		14	3	17	24	
2JD-06-20	U9/16"X18	M20x1.5	12		14	3	19	27	
2JD-06-22	U9/16"X18	M22x1.5	14		14	2.5	22	27	
2JD-08-22	U3/4"X16	M22x1.5	14		16.7	2.5	22	27	
2JD-08-24	U3/4"X16	M24x1.5	16		16.7	3.5	24	30	
2JD-10-30	U7/8"X14	M30x2	20		19.5	4.5	30	36	
2JD-10-36	U7/8"X14	M36x2	25		19.5	3.5	36	41	
2JD-12-30	U1.1/16"X12	M30x2	20		22	4.5	30	36	
2JD-12-36	U1.1/16"X12	M36x2	25		22	3.5	36	41	
2JD-16-42	U1.5/16"X12	M42x2	30		23	5.5	41	50	
2JD-20-42	U1.5/8"X12	M42x2	30		24.5	5.5	46	50	
2JD-20-52	U1.5/8"X12	M52x2	38		24.5	7	50	60	
2JD-24-52	U1.7/8"X12	M52x2	38		27.5	7	50	60	

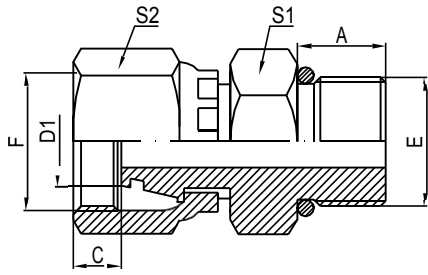

# 2GC

公制螺纹24°轻系列锥O型圈/  
英管螺纹 O型圈密封  
METRIC FEMALE 24° L.T.CONE O-RING/  
BSP MALE O-RING

代号 PART NO.	螺纹 THREADE		管子外径 TUBE O.D.		尺寸 DIMENSIONS				
	E	F	D1		A	C	S1	S2	
2GC-02-12	G1/8"X28	M12x1.5	6		9	2	14	17	
2GC-04-14	G1/4"X19	M14x1.5	8		12	3.5	19	19	
2GC-04-16	G1/4"X19	M16x1.5	10		12	3.5	19	22	
2GC-06-18	G3/8"X19	M18x1.5	12		13.5	3.5	22	24	
2GC-08-22	G1/2"X14	M22x1.5	15		16	3	27	27	
2GC-08-26	G1/2"X14	M26x1.5	18		16	3.5	27	32	
2GC-12-30	G3/4"X14	M30x2	22		18.5	4.5	32	36	
2GC-16-36	G1"X11	M36x2	28		20.5	4.5	41	41	
2GC-20-45	G1.1/4"X11	M45x2	35		20.5	5.5	50	55	
2GC-24-52	G1.1/2"X11	M52x2	42		23	6.5	55	60	

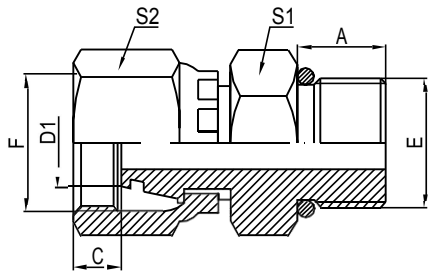

# 2GD

公制螺纹24°重系列锥O型圈/  
英管螺纹 O型圈密封  
METRIC FEMALE 24° H.T.CONE O-RING/  
BSP MALE O-RING

代号 PART NO.	螺纹 THREADE		管子外径 TUBE O.D.		尺寸 DIMENSIONS				
	E	F	D1		A	C	S1	S2	
2GD-04-14	G1/4"X19	M14x1.5	6		12	3	19	19	
2GD-04-16	G1/4"X19	M16x1.5	8		12	3.5	19	22	
2GD-06-18	G3/8"X19	M18x1.5	10		13.5	3	22	24	
2GD-06-20	G3/8"X19	M20x1.5	12		13.5	3	22	27	
2GD-08-22	G1/2"X14	M22x1.5	14		16	2.5	27	27	
2GD-08-24	G1/2"X14	M24x1.5	16		16	3.5	27	30	
2GD-12-30	G3/4"X14	M30x2	20		18.5	4.5	32	36	
2GD-16-36	G1"X11	M36x2	25		20.5	3.5	41	41	
2GD-20-42	G1.1/4"X11	M42x2	30		20.5	5.5	50	50	
2GD-24-52	G1.1/2"X11	M52x2	38		23	7	55	60	



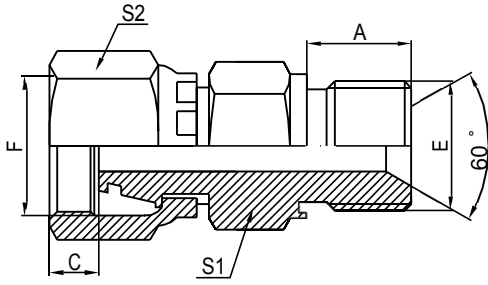

## 2MC-WD

公制螺纹胶垫密封/ 公制内螺纹24°  
 锥面O型圈密封轻系列  
 METRIC THREAD /METRIC FEMALE  
 24° CONE O-RING SEAL L.T.

代号 PART NO.	螺纹 THREADE		管子外径 TUBE O.D.		尺寸 DIMENSIONS				
	E	F	D1		A	C	S1	S2	
2MC-12-14WD	M12x1.5	M14x1.5	8		10	3.5	17	19	
2MC-14-16WD	M14x1.5	M16x1.5	10		11	3.5	19	22	
2MC-16-18WD	M16x1.5	M18x1.5	12		12	3.5	22	24	
2MC-18-22WD	M18x1.5	M22x1.5	15		12	3	24	27	
2MC-22-26WD	M22x1.5	M26x1.5	18		14	3.5	27	32	

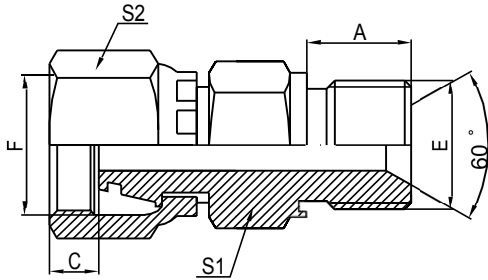

## 2MD-WD

公制螺纹胶垫密封/ 公制内螺纹24°  
 锥面O型圈密封重系列  
 METRIC THREAD /METRIC FEMALE  
 24° CONE O-RING SEAL H.T.

代号 PART NO.	螺纹 THREADE		管子外径 TUBE O.D.		尺寸 DIMENSIONS				
	E	F	D1		A	C	S1	S2	
2MD-12-14WD	M12x1.5	M14x1.5	6		10	3	17	19	
2MD-14-16WD	M14x1.5	M16x1.5	8		11	3.5	19	22	
2MD-16-18WD	M16x1.5	M18x1.5	10		12	3	22	24	
2MD-18-20WD	M18x1.5	M20x1.5	12		12	3	24	27	
2MD-22-24WD	M22x1.5	M22x1.5	16		14	3.5	27	30	

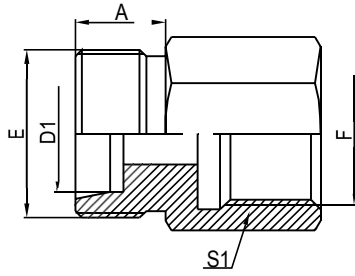

# 5CB

公制螺纹24°轻系列/ 英管内螺纹  
METRIC MALE 24° L.T./BSP FEMALE

代号 PART NO.	螺纹 THREADE		管子外径 TUBE O.D.		尺寸 DIMENSIONS				
	E	F	D1		A		S1		
5CB-12-02	M12x1.5	G1/8"X28	6		10		14		
5CB-12-04	M12x1.5	G1/4"X19	6		10		19		
5CB-14-04	M14x1.5	G1/4"X19	8		11		19		
5CB-14-06	M14x1.5	G3/8"X19	8		11		24		
5CB-14-08	M14x1.5	G1/2"X14	8		11		27		
5CB-16-04	M16x1.5	G1/4"X19	10		11		19		
5CB-16-06	M16x1.5	G3/8"X19	10		11		24		
5CB-16-08	M16x1.5	G1/2"X14	10		11		27		
5CB-18-04	M18x1.5	G1/4"X19	12		11.5		19		
5CB-18-06	M18x1.5	G3/8"X19	12		11.5		24		
5CB-18-08	M18x1.5	G1/2"X14	12		11.5		27		
5CB-22-06	M22x1.5	G3/8"X19	15		12.5		24		
5CB-22-08	M22x1.5	G1/2"X14	15		12.5		27		
5CB-26-08	M26x1.5	G1/2"X14	18		12		27		
5CB-30-12	M30x2	G3/4"X14	22		14		36		
5CB-36-16	M36x2	G1"X11	28		16		41		
5CB-45-20	M45x2	G1.1/4"X11	35		18		55		
5CB-52-24	M52x2	G1.1/2"X11	42		19		60		

备注:如需带卡套及卡套螺母整套订货,则请在代号后加"RN",如"5CB-22-08RN"  
Remark:In case if you are interested to order the adapter in complete set with cutting ring and nut,it is necessary to insert suffix"RN" arter our part NO.,for example 5CB-22-08RN.

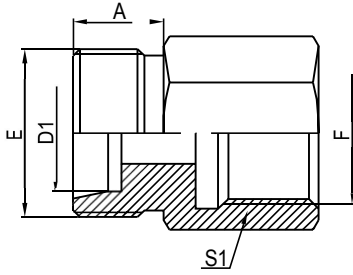

# 5DB

公制螺纹24°重系列/ 英管内螺纹  
METRIC MALE 24° H.T./BSP FEMALE

代号 PART NO.	螺纹 THREADE		管子外径 TUBE O.D.		尺寸 DIMENSIONS				
	E	F	D1		A		S1		
5DB-14-04	M14x1.5	G1/4"X19	6		12		19		
5DB-16-04	M16x1.5	G1/4"X19	8		12		19		
5DB-18-06	M18x1.5	G3/8"X19	10		12		24		
5DB-20-06	M20x1.5	G3/8"X19	12		12		24		
5DB-20-08	M20x1.5	G1/2"X14	12		12		24		
5DB-22-08	M22x1.5	G1/2"X14	14		14		30		
5DB-24-08	M24x1.5	G1/2"X14	16		14		30		
5DB-30-12	M30x2	G3/4"X14	20		16		36		
5DB-36-16	M36x2	G1"X11	25		18		41		
5DB-42-20	M42x2	G1.1/4"X11	30		20		55		
5DB-52-24	M52x2	G1.1/2"X11	38		22		60		

备注:如需带卡套及卡套螺母整套订货,则请在代号后加"RN",如"5DB-22-08RN"

Remark:In case if you are interested to order the adapter in complete set with cutting ring and nut,it is necessary to insert suffix"RN" arter our part NO.,for example 5DB-22-08RN.

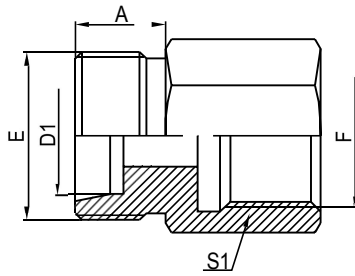

# 5CM

公制螺纹24°轻系列/ 公制内螺纹  
METRIC MALE 24° L.T./METRIC FEMALE

代号 PART NO.	螺纹 THREADE		管子外径 TUBE O.D.		尺寸 DIMENSIONS				
	E	F	D1		A		S1		
5CM-12-10	M12x1.5	M10x1	6		10		14		
5CM-14-12	M14x1.5	M12x1.5	8		11		17		
5CM-16-14	M16x1.5	M14x1.5	10		11		19		
5CM-18-16	M18x1.5	M16x1.5	12		11.5		22		
5CM-22-18	M22x1.5	M18x1.5	15		12.5		24		
5CM-26-22	M26x1.5	M22x1.5	18		12		30		
5CM-30-26	M30x2	M26x1.5	22		14		32		
5CM-36-33	M36x2	M33x2	28		16		41		
5CM-45-42	M45x2	M42x2	35		18		55		
5CM-52-48	M52x2	M48x2	42		19		60		

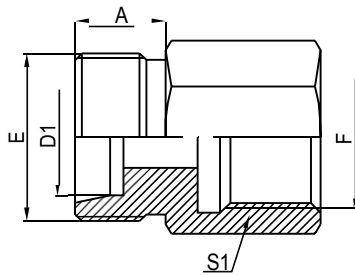

# 5DM

公制螺纹24°重系列/ 公制内螺纹  
METRIC MALE 24° H.T./METRIC FEMALE

代号 PART NO.	螺纹 THREADE		管子外径 TUBE O.D.		尺寸 DIMENSIONS				
	E	F	D1		A		S1		
5DM-14-12	M14x1.5	M12x1.5	6		12		17		
5DM-16-14	M16x1.5	M14x1.5	8		12		19		
5DM-18-16	M18x1.5	M16x1.5	10		12		22		
5DM-20-18	M20x1.5	M18x1.5	12		12		24		
5DM-22-20	M22x1.5	M20x1.5	14		14		27		
5DM-24-22	M24x1.5	M22x1.5	16		14		30		
5DM-30-27	M30x2	M27x1.5	20		16		36		
5DM-36-33	M36x2	M33x2	25		18		41		
5DM-42	M42x2	M42x2	30		20		55		
5DM-52-48	M52x2	M48x2	38		22		60		

备注: 如需带卡套及卡套螺母整套订货, 则请在代号后加"RN", 如"5DM-20-18RN"(同上)  
Remark: In case if you are interested to order the adapter in complete set with cutting ring and nut, it is necessary to insert suffix"RN" arter our part NO., for example 5DM-20-18RN. (the same with above)

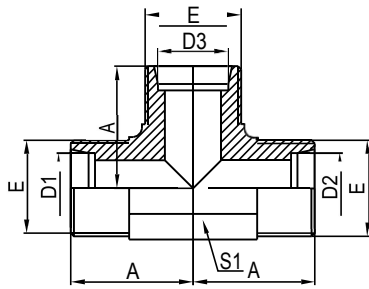

# AC

公制外螺纹24°轻系列三通  
METRIC MALE 24° L.T. TEE

代号 PART NO.	螺纹 THREADE		管子外径 TUBE O.D.		尺寸 DIMENSIONS				
	E		D1,D2,D3		A		S1		
AC-12	M12x1.5		6		23		11		
AC-14	M14x1.5		8		27		14		
AC-16	M16x1.5		10		29		17		
AC-18	M18x1.5		12		32		19		
AC-22	M22x1.5		15		33		22		
AC-26	M26x1.5		18		40		27		
AC-30	M30x2		22		40		27		
AC-36	M36x2		28		46		33		

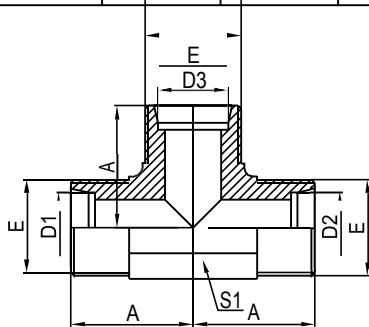

# AD

公制外螺纹24°重系列三通  
METRIC MALE 24° H.T. TEE

代号 PART NO.	螺纹 THREADE		管子外径 TUBE O.D.		尺寸 DIMENSIONS				
	E		D1,D2,D3		A		S1		
AD-14	M14x1.5		6		27		14		
AD-16	M16x1.5		8		29		17		
AD-18	M18x1.5		10		32		19		
AD-20	M20x1.5		12		33		22		
AD-22	M22x1.5		14		33		22		
AD-24	M24x1.5		16		33		24		
AD-30	M30x2		20		40		27		
AD-33	M33x2		22		46		33		
AD-42	M42x2		30		57		44		

备注:如需带卡套及卡套螺母整套订货,则请在代号后加"RN",如"AD-22RN"(同上)

Remark: In case if you are interested to order the adapter in complete set with cutting ring and nut, it is necessary to insert suffix "RN" after our part NO., for example AD-22RN. (the same with above)

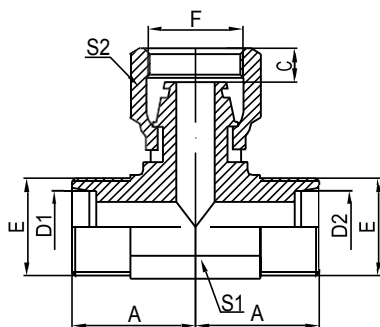

# BC

公制内螺纹24° / 公制外螺  
纹24° 轻系列三通  
METRIC FEMALE 24° / METRIC  
MALE 24° L.T. TEE

代号 PART NO.	螺纹 THREADE		管子外径 TUBE O.D.		尺寸 DIMENSIONS				
	E	F	D1	D2	A	C	S1	S2	
BC-12	M12x1.5	M12x1.5	6	6	23	2	11	17	
BC-14	M14x1.5	M14x1.5	8	8	27	3.5	14	19	
BC-16	M16x1.5	M16x1.5	10	10	29	3.5	17	22	
BC-18	M18x1.5	M18x1.5	12	12	32	3.5	19	24	
BC-22	M22x1.5	M22x1.5	15	15	33	3	22	27	
BC-26	M26x1.5	M26x1.5	18	18	40	3.5	27	32	
BC-30	M30x2	M30x2	22	22	40	4.5	27	36	
BC-36	M36x2	M36x2	28	28	46	4.5	33	41	

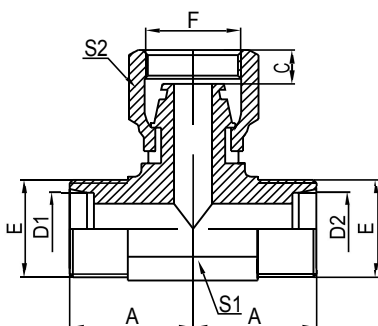

# BD

公制内螺纹24° / 公制外螺  
纹24° 重系列三通  
METRIC FEMALE 24° / METRIC  
MALE 24° H.T. TEE

代号 PART NO.	螺纹 THREADE		管子外径 TUBE O.D.		尺寸 DIMENSIONS				
	E	F	D1	D2	A	C	S1	S2	
BD-14	M14x1.5	M14x1.5	6	6	27	3	14	19	
BD-16	M16x1.5	M16x1.5	8	8	29	3.5	17	22	
BD-18	M18x1.5	M18x1.5	10	10	32	3	19	24	
BD-20	M20x1.5	M20x1.5	12	12	33	3	22	27	
BD-22	M22x1.5	M22x1.5	14	14	33	2.5	22	27	
BD-24	M24x1.5	M24x1.5	16	16	33	3.5	24	30	
BD-30	M30x2	M30x2	20	20	40	4.5	27	36	
BD-36	M36x2	M36x2	25	25	46	3.5	33	41	
BD-42	M42x2	M42x2	30	30	57	5.5	44	50	

备注:如需带卡套及卡套螺母整套订货,则请在代号后加"RN",如"BD-22RN"(同上)

Remark: In case if you are interested to order the adapter in complete set with cutting ring and nut, it is necessary to insert suffix "RN" after our part NO., for example BD-22RN. (the same with above)

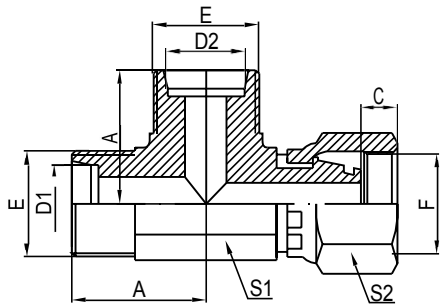

# CC

公制外螺纹24° / 公制内螺纹24° 轻系列三通METRIC  
 MALE 24° / METRIC  
 FEMALE 24° L.T. TEE

代号 PART NO.	螺纹 THREADE		管子外径 TUBE O.D.		尺寸 DIMENSIONS				
	E	F	D1	D2	A	C	S1	S2	
CC-12	M12x1.5	M12x1.5	6	6	23	2	11	17	
CC-14	M14x1.5	M14x1.5	8	8	27	3.5	14	19	
CC-16	M16x1.5	M16x1.5	10	10	29	3.5	17	22	
CC-18	M18x1.5	M18x1.5	12	12	32	3.5	19	24	
CC-22	M22x1.5	M22x1.5	15	15	33	3	22	27	
CC-26	M26x1.5	M26x1.5	18	18	40	3.5	27	32	
CC-30	M30x2	M30x2	22	22	40	4.5	27	36	
CC-36	M36x2	M36x2	28	28	46	4.5	33	41	

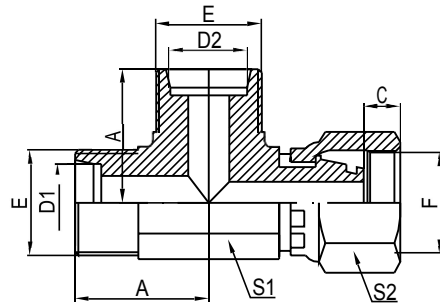

# CD

公制外螺纹24° / 公制内螺纹24° 重系列三通METRIC  
 MALE 24° / METRIC  
 FEMALE 24° H.T. TEE

代号 PART NO.	螺纹 THREADE		管子外径 TUBE O.D.		尺寸 DIMENSIONS				
	E	F	D1	D2	A	C	S1	S2	
BD-14	M14x1.5	M14x1.5	6	6	27	3	14	19	
BD-16	M16x1.5	M16x1.5	8	8	29	3.5	17	22	
BD-18	M18x1.5	M18x1.5	10	10	32	3	19	24	
BD-20	M20x1.5	M20x1.5	12	12	33	3	22	27	
BD-22	M22x1.5	M22x1.5	14	14	33	2.5	22	27	
BD-24	M24x1.5	M24x1.5	16	16	33	3.5	24	30	
BD-30	M30x2	M30x2	20	20	40	4.5	27	36	
BD-36	M36x2	M36x2	25	25	46	3.5	33	41	
BD-42	M42x2	M42x2	30	30	57	5.5	44	50	

备注:如需带卡套及卡套螺母整套订货,则请在代号后加"RN",如"BD-22RN" (同上)  
 Remark:In case if you are interested to order the adapter in complete set with cutting ring and nut, it is necessary to insert suffix"RN" arter our part NO.,for example BD-22RN. (the same with above)

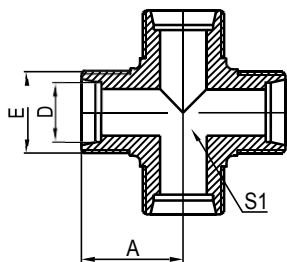

# XC

公制外螺纹24°轻系列四通  
METRIC MALE 24° L.T. CROSS

代号 PART NO.	螺纹 THREADE		管子外径 TUBE O.D.		尺寸 DIMENSIONS				
	E		D		A		S1		
XC-12	M12x1.5		6		23		11		
XC-14	M14x1.5		8		27		14		
XC-16	M16x1.5		10		29		17		
XC-18	M18x1.5		12		32		19		
XC-22	M22x1.5		15		33		22		
XC-26	M26x1.5		18		40		27		
XC-30	M30x2		22		40		27		
XC-33	M33x2		25		46		33		

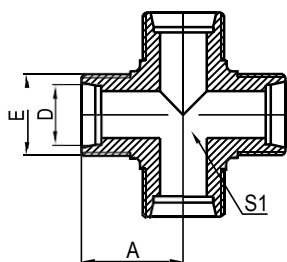

# XD

公制外螺纹24°重系列四通  
METRIC MALE 24° H.T. CROSS

代号 PART NO.	螺纹 THREADE		管子外径 TUBE O.D.		尺寸 DIMENSIONS				
	E		D		A		S1		
XD-14	M14x1.5		6		27		14		
XD-16	M16x1.5		8		29		17		
XD-18	M18x1.5		10		32		19		
XD-20	M20x1.5		12		32		19		
XD-22	M22x1.5		14		33		22		
XD-24	M24x1.5		16		33		24		
XD-30	M30x2		20		40		27		
XD-33	M33x2		22		46		33		
XD-42	M42x2		30		57		44		

备注:如需带卡套及卡套螺母整套订货,则请在代号后加"RN",如"XD-22RN"(同上)

Remark: In case if you are interested to order the adapter in complete set with cutting ring and nut, it is necessary to insert suffix "RN" after our part NO., for example XD-22RN. (the same with above)



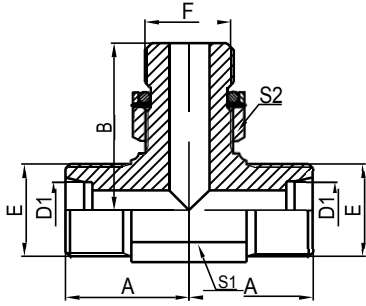

# ACHC-OG

公制外螺纹24°轻系列可调向柱端分支三通  
METRIC MALE 24° L.T.ADJUSTABLE  
STUD BRADCH TEE

代号 PART NO.	螺纹 THREADE		管子外径 TUBE O.D.		O型圈 O-RING	尺寸 DIMENSIONS				
	E	F	D1			A	B	S1	S2	
ACHC-12-10-12OG	M12x1.5	M10x1	6		8.1x1.6	23	26.5	11	14	
ACHC-14-12-14OG	M14x1.5	M12x1.5	8		9.3x2.4	27	32	14	17	
ACHC-16-14-16OG	M16x1.5	M14x1.5	10		11.3x2.4	29	34	17	19	
ACHC-18-16-18OG	M18x1.5	M16x1.5	12		13.3x2.4	32	36	19	22	
ACHC-22-18-22OG	M22x1.5	M18x1.5	15		15.3x2.4	33	39.5	22	24	
ACHC-26-22-26OG	M26x1.5	M22x1.5	18		19.3x2.4	40	43.5	37	27	
ACHC-30-27-30OG	M30x2	M27x2	22		23.5x3	40	50	27	32	
ACHC-36-33-36OG	M36x2	M33x2	28		29.5x3	46	54	33	41	

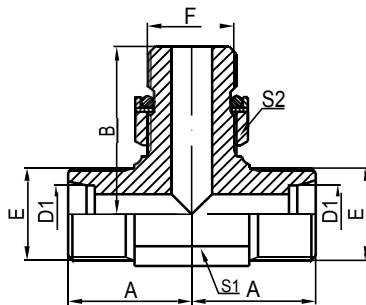

# ADHD-OG

公制外螺纹24°重系列可调向柱端分支三通  
METRIC MALE 24° H.T.ADJUSTABLE  
STUD BRADCH TEE

代号 PART NO.	螺纹 THREADE		管子外径 TUBE O.D.		O型圈 O-RING	尺寸 DIMENSIONS				
	E	F	D1			A	B	S1	S2	
ADHD-14-12-14OG	M14x1.5	M12x1.5	6		9.3x2.4	27	32	14	17	
ADHD-16-14-16OG	M16x1.5	M14x1.5	8		11.3x2.4	29	34	17	19	
ADHD-18-16-18OG	M18x1.5	M16x1.5	10		13.3x2.4	32	36	19	22	
ADHD-20-18-20OG	M20x1.5	M18x1.5	12		15.3x2.4	33	37	22	24	
ADHD-24-22-24OG	M24x1.5	M22x1.5	16		19.3x2.4	33	37.5	24	27	
ADHD-30-27-30OG	M30x2	M27x2	20		23.5x3	40	50	27	32	
ADHD-36-33-36OG	M36x2	M33x2	25		29.5x3	46	54	33	41	
ADHD-42-42-42OG	M42x2	M42x2	30		38.5x3	57	57.2	44	50	

备注:如需带卡套及卡套螺母整套订货,则请在代号后加"RN",如"ADHD-20-18OG/RN" (同上)

Remark: In case if you are interested to order the adapter in complete set with cutting ring and nut, it is necessary to insert suffix "RN" arter our part NO. , for example ADHD-20-18OG/RN. (the same with above)

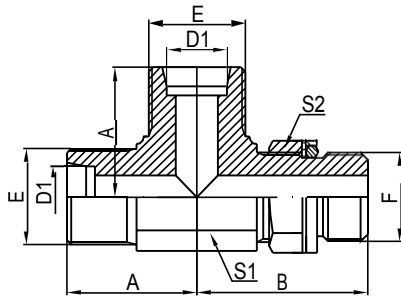

## ACCH-OG

公制外螺纹24°轻系列可  
调向柱端主支三通METRIC  
MALE 24° L.T.  
ADJUSTABLE STUD RUN TEE

代号 PART NO.	螺纹 THREADS		管子外径 TUBE O.D.		O型圈 O-RING	尺寸 DIMENSIONS			
	E	F	D1			A	B	S1	S2
ACCH-12-12-100G	M12x1.5	M10x1	6		8.1x1.6	23	26.5	11	14
ACCH-14-14-120G	M14x1.5	M12x1.5	8		9.3x2.4	27	32	14	17
ACCH-16-16-140G	M16x1.5	M14x1.5	10		11.3x2.4	29	34	17	19
ACCH-18-18-160G	M18x1.5	M16x1.5	12		13.3x2.4	32	36	19	22
ACCH-22-22-180G	M22x1.5	M18x1.5	15		15.3x2.4	33	39.5	22	24
ACCH-26-26-220G	M26x1.5	M22x1.5	18		19.3x2.4	40	43.5	27	27
ACCH-30-30-270G	M30x2	M27x2	22		23.5x3	40	50	27	32
ACCH-36-36-330G	M36x2	M33x2	28		29.5x3	46	54	33	41

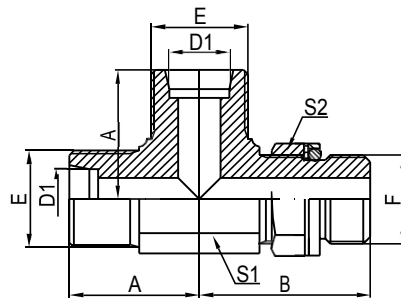

## ADDH-OG

公制外螺纹24°重系列可  
调向柱端主支三通METRIC  
MALE 24° H.T.  
ADJUSTABLE STUD RUN TEE

代号 PART NO.	螺纹 THREADS		管子外径 TUBE O.D.		O型圈 O-RING	尺寸 DIMENSIONS			
	E	F	D1			A	B	S1	S2
ADDH-14-14-120G	M14x1.5	M12x1.5	6		9.3x2.4	27	32	14	17
ADDH-16-16-140G	M16x1.5	M14x1.5	8		11.3x2.4	29	34	17	19
ADDH-18-18-160G	M18x1.5	M16x1.5	10		13.3x2.4	32	36	19	22
ADDH-20-20-180G	M20x1.5	M18x1.5	12		15.3x2.4	33	37	22	24
ADDH-24-24-220G	M24x1.5	M22x1.5	16		19.3x2.4	33	37.5	24	27
ADDH-30-30-270G	M30x2	M27x2	20		23.5x3	40	50	27	32
ADDH-36-36-330G	M36x2	M33x2	25		29.5x3	46	54	33	41
ADDH-42-42-420G	M42x2	M42x2	30		38.5x3	57	57.2	44	50

备注:如需带卡套及卡套螺母整套订货,则请在代号后加"RN",如"ADDH-20-20-180G/RN" (同上)  
Remark:In case if you are interested to order the adapter in complete set with cutting ring and nut, it is necessary to insert suffix "RN" after our part NO., for example ADDH-20-20-180G/RN. (the same with above)

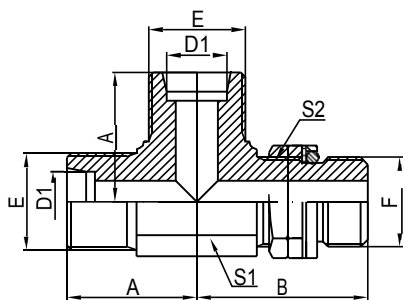

# ACCG-OG

公制外螺纹24°轻系列  
/英管可调向柱端主支三通  
METRIC MALE 24° L.T.  
/BSP MALE ADJUSTABLE STUD RUN TEE

代号 PART NO.	螺纹 THREADE		管子外径 TUBE O.D.		尺寸 DIMENSIONS				
	E	F	D1		A	B	S1	S2	
ACCG-12-12-02OG	M12x1.5	G1/8"X28	6		23	26.2	11	14	
ACCG-14-14-04OG	M14x1.5	G1/4"X19	8		27	31.3	14	17	
ACCG-16-16-04OG	M16x1.5	G1/4"X19	10		29	32.5	17	19	
ACCG-18-18-06OG	M18x1.5	G3/8"X19	12		32	36.8	19	22	
ACCG-22-22-08OG	M22x1.5	G1/2"X14	15		33	43.2	22	24	
ACCG-26-26-08OG	M26x1.5	G1/2"X14	18		33	46.5	27	27	
ACCG-30-30-12OG	M30x2	G3/4"X14	22		40	52	27	32	
ACCG-36-36-16OG	M36x2	G1"X11	28		46	56	33	41	

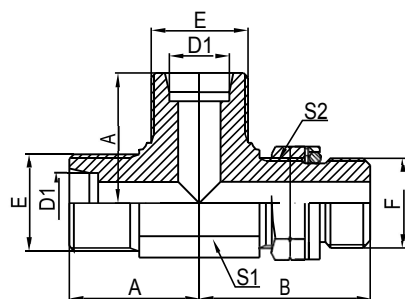

# ADDG-OG

公制外螺纹24°重系列  
/英管可调向柱端主支三通  
METRIC MALE 24° H.T.  
/BSP MALE ADJUSTABLE STUD RUN TEE

代号 PART NO.	螺纹 THREADE		管子外径 TUBE O.D.		尺寸 DIMENSIONS				
	E	F	D1		A	B	S1	S2	
ADDG-14-14-04OG	M14x1.5	G1/4"X19	6		27	31.3	14	19	
ADDG-16-16-04OG	M16x1.5	G1/4"X19	8		29	32.5	17	19	
ADDG-18-18-06OG	M18x1.5	G3/8"X19	10		32	36.8	19	22	
ADDG-20-20-06OG	M20x1.5	G3/8"X19	12		33	36.8	22	22	
ADDG-22-22-08OG	M22x1.5	G1/2"X14	14		33	43.2	22	27	
ADDG-24-24-08OG	M24x1.5	G1/2"X14	16		33	44	24	27	
ADDG-30-30-12OG	M30x2	G3/4"X14	20		40	52	27	32	
ADDG-36-36-16OG	M36x2	G1"X11	25		46	56	33	41	
ADDG-42-42-20OG	M42x2	G1.1/4"X11	30		57	58	44	50	

备注:如需带卡套及卡套螺母整套订货,则请在代号后加"RN",如"ADDG-20-20-06OG/RN" (同上)  
Remark:In case if you are interested to order the adapter in complete set with cutting ring and nut, it is necessary to insert suffix"RN" arter our part NO., for example ADDG-20-20-06OG/RN.(the same with above)

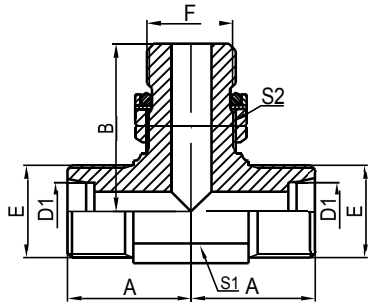

# ACGC-OG

公制外螺纹24°轻系列  
/英管可调向柱端分支三通  
METRIC MALE 24° L.T.  
/BSP MALE ADJUSTABLE STUD BRANCH TEE

代号 PART NO.	螺纹 THREADE		管子外径 TUBE O.D.		尺寸 DIMENSIONS				
	E	F	D1		A	B	S1	S2	
ACGC-12-02-12OG	M12x1.5	G1/8"X28	6		23	26.2	11	14	
ACGC-14-04-14OG	M14x1.5	G1/4"X19	8		27	31.3	14	19	
ACGC-16-04-16OG	M16x1.5	G1/4"X19	10		29	32.5	17	19	
ACGC-18-06-18OG	M18x1.5	G3/8"X19	12		32	36.8	19	22	
ACGC-22-08-22OG	M22x1.5	G1/2"X14	15		33	43.2	22	27	
ACGC-26-08-26OG	M26x1.5	G1/2"X14	18		33	46.5	27	27	
ACGC-30-12-30OG	M30x2	G3/4"X14	22		40	52	27	32	
ACGC-36-16-36OG	M36x2	G1"X11	28		46	56	33	41	

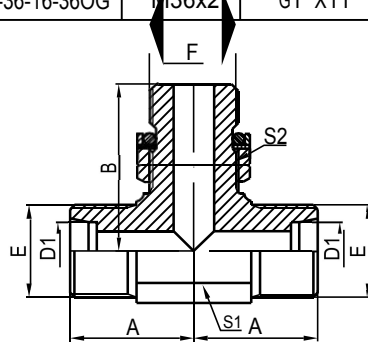

# ADGD-OG

公制外螺纹24°重系列  
/英管可调向柱端分支三通  
METRIC MALE 24° H.T.  
/BSP MALE ADJUSTABLE STUD BRANCH TEE

代号 PART NO.	螺纹 THREADE		管子外径 TUBE O.D.		尺寸 DIMENSIONS				
	E	F	D1		A	B	S1	S2	
ADGD-14-04-14OG	M14x1.5	G1/4"X19	6		27	31.3	14	19	
ADGD-16-04-16OG	M16x1.5	G1/4"X19	8		29	32.5	17	19	
ADGD-18-06-18OG	M18x1.5	G3/8"X19	10		32	36.8	19	22	
ADGD-20-06-20OG	M20x1.5	G3/8"X19	12		33	36.8	22	22	
ADGD-22-08-22OG	M22x1.5	G1/2"X14	14		33	43.2	22	27	
ADGD-24-08-24OG	M24x1.5	G1/2"X14	16		33	44	24	27	
ADGD-30-12-30OG	M30x2	G3/4"X14	20		40	52	27	32	
ADGD-36-16-36OG	M36x2	G1"X11	25		46	56	33	41	
ADGD-42-20-42OG	M42x2	G1.1/4"X11	30		57	58	44	50	

备注:如需带卡套及卡套螺母整套订货,则请在代号后加"RN",如"ADGD-20-06-20OG/RN" (同上)  
Remark:In case if you are interested to order the adapter in complete set with cutting ring and nut, it is necessary to insert suffix"RN" arter our part NO., for example ADGD-20-06-20OG/RN.(the same with above)

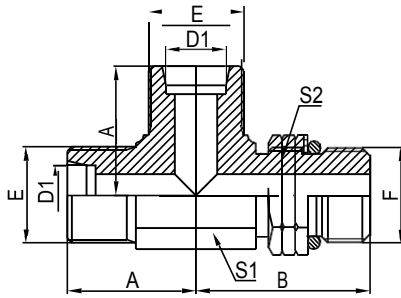

# ACCO-OG

公制24°轻系列  
 /美制可调向柱端主支三通  
 METRIC MALE 24° L.T.  
 /SAE MALE ADJUSTABLE STUD RUN TEE

代号 PART NO.	螺纹 THREADS		管子外径 TUBE O.D.		尺寸 DIMENSIONS				
	E	F	D1		A	B	S1	S2	
ACCO-12-12-04OG	M12x1.5	U7 / 16"X20	6		23	27.2	11	17	
ACCO-14-14-06OG	M14x1.5	U9 / 16"X18	8		27	31.8	14	19	
ACCO-16-16-06OG	M16x1.5	U9 / 16"X18	10		29	33.3	17	19	
ACCO-18-18-08OG	M18x1.5	U3 / 4"X16	12		32	37.5	19	24	
ACCO-22-22-10OG	M22x1.5	U7 / 8"X14	15		33	44	22	27	
ACCO-26-26-12OG	M26x1.5	U1.1 / 16"X12	18		40	51	27	32	
ACCO-30-30-12OG	M30x2	U1.1 / 16"X12	22		40	53.5	27	32	
ACCO-36-36-16OG	M36x2	U1.5 / 16"X12	28		46	57.5	33	41	

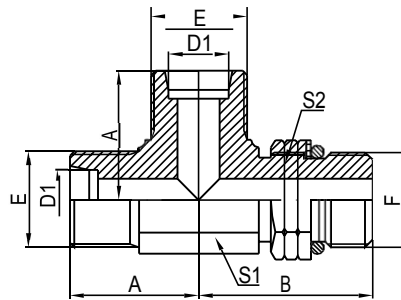

# ADDO-OG

公制24°重系列  
 /美制可调向柱端主支三通  
 METRIC MALE 24° H.T.  
 /SAE MALE ADJUSTABLE STUD RUN TEE

代号 PART NO.	螺纹 THREADS		管子外径 TUBE O.D.		尺寸 DIMENSIONS				
	E	F	D1		A	B	S1	S2	
ADDO-14-14-04OG	M14x1.5	U7 / 16"X20	6		27	30	14	17	
ADDO-16-16-06OG	M16x1.5	U9 / 16"X18	8		29	33.3	17	19	
ADDO-18-18-06OG	M18x1.5	U9 / 16"X18	10		32	33.5	19	19	
ADDO-20-20-08OG	M20x1.5	U3 / 4"X16	12		33	37.5	22	24	
ADDO-22-22-10OG	M22x1.5	U7 / 8"X14	14		33	44	22	27	
ADDO-24-24-10OG	M24x1.5	U7 / 8"X14	16		33	46.5	24	27	
ADDO-30-30-12OG	M30x2	U1.1 / 16"X12	20		40	53.5	27	32	
ADDO-36-36-16OG	M36x2	U1.5 / 16"X12	25		46	57.5	33	41	
ADDO-42-42-20OG	M42x2	U1.5 / 8"X12	30		57	59.5	44	50	

备注:如需带卡套及卡套螺母整套订货,则请在代号后加"RN",如"ADDO-20-20-08OG/RN" (同上)  
 Remark:In case if you are interested to order the adapter in complete set with cutting ring and nut, it is necessary to insert suffix "RN" arter our part NO., for example ADDO-20-20-08OG/RN. (the same with above)

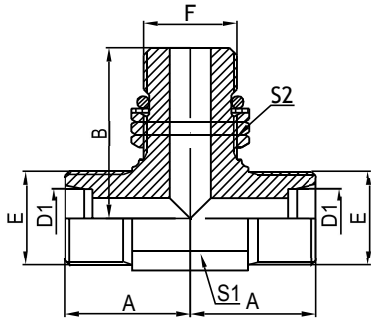

# ACOC-OG

公制24°轻系列  
 /美制可调向柱端分支三通  
 METRIC MALE 24° L.T.  
 /SAE MALE ADJUSTABLE STUD BRANCH TEE

代号 PART NO.	螺纹 THREADS		管子外径 TUBE O.D.		尺寸 DIMENSIONS				
	E	F	D1		A	B	S1	S2	
ACOC-12-04-12OG	M12x1.5	U7 / 16"X20	6		23	27.2	11	17	
ACOC-14-06-14OG	M14x1.5	U9 / 16"X18	8		27	31.8	14	19	
ACOC-16-06-16OG	M16x1.5	U9 / 16"X18	10		29	33.3	17	19	
ACOC-18-08-18OG	M18x1.5	U3 / 4"X16	12		32	37.5	19	24	
ACOC-22-10-22OG	M22x1.5	U7 / 8"X14	15		33	44	22	27	
ACOC-26-12-26OG	M26x1.5	U1.1 / 16"X12	18		40	51	27	32	
ACOC-30-12-30OG	M30x2	U1.1 / 16"X12	22		40	53.5	27	32	
ACOC-36-16-36OG	M36x2	U1.5 / 16"X12	28		46	57.5	33	41	

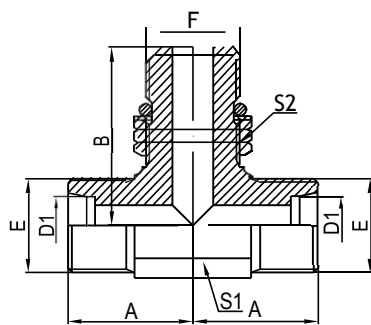

# ADOD-OG

公制24°重系列  
 /美制可调向柱端分支三通  
 METRIC MALE 24° H.T.  
 /SAE MALE ADJUSTABLE STUD BRANCH TEE

代号 PART NO.	螺纹 THREADS		管子外径 TUBE O.D.		尺寸 DIMENSIONS				
	E	F	D1		A	B	S1	S2	
ADOD-14-04-14OG	M14x1.5	U7 / 16"X20	6		27	30	14	17	
ADOD-16-06-16OG	M16x1.5	U9 / 16"X18	8		29	33.3	17	19	
ADOD-18-06-18OG	M18x1.5	U9 / 16"X18	10		32	33.5	19	19	
ADOD-20-08-20OG	M20x1.5	U3 / 4"X16	12		33	37.5	22	24	
ADOD-22-10-22OG	M22x1.5	U7 / 8"X14	14		33	44	22	27	
ADOD-24-10-24OG	M24x1.5	U7 / 8"X14	16		33	46.5	24	27	
ADOD-30-12-30OG	M30x2	U1.1 / 16"X12	20		40	53.5	27	32	
ADOD-36-16-36OG	M36x2	U1.5 / 16"X12	25		46	57.5	33	41	
ADOD-42-20-42OG	M42x2	U1.5 / 8"X12	30		57	59.5	44	50	

备注:如需带卡套及卡套螺母整套订货,则请在代号后加"RN",如"ADOD-20-08-20OG/RN" (同上)  
 Remark: In case if you are interested to order the adapter in complete set with cutting ring and nut, it is necessary to insert suffix "RN" after our part NO., for example ADOD-20-08-20OG/RN. (the same with above)

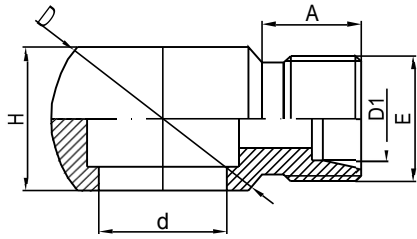

# 1CL-B

公制螺纹24°轻系列/ 英管螺纹铰接接头  
METRIC MALE 24° L.T./BSP BANJO

代号 PART NO.	螺纹 THREADE		管子外径 TUBE O.D.		配用螺栓 BOLT	尺寸 DIMENSIONS			
	E		D1			A	d	D	H
1CL-12-B02	M12x1.5		6		720B-02	10	9.9	22	16
1CL-14-B04	M14x1.5		8		720B-04	11	13.3	24	15
1CL-16-B04	M16x1.5		10		720B-04	11	13.3	24	15
1CL-18-B06	M18x1.5		12		720B-06	11.5	16.7	29	20
1CL-22-B08	M22x1.5		15		720B-08	12.5	21	38	25
1CL-26-B08	M26x1.5		18		720B-08	12	21	38	25
1CL-30-B12	M30x2		22		720B-12	14	26.5	46	31

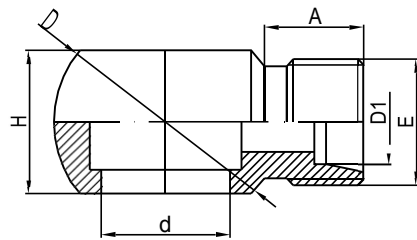

# 1DL-B

公制螺纹24°重系列/ 英管螺纹铰接接头  
METRIC MALE 24° H.T./BSP BANJO

代号 PART NO.	螺纹 THREADE		管子外径 TUBE O.D.		配用螺栓 BOLT	尺寸 DIMENSIONS			
	E		D1			A	d	D	H
1DL-14-B04	M14x1.5		6		720B-04	12	13.3	24	15
1DL-16-B04	M16x1.5		8		720B-04	12	13.3	24	15
1DL-18-B06	M18x1.5		10		720B-06	12	16.7	29	20
1DL-20-B06	M20x1.5		12		720B-06	12	16.7	29	20
1DL-22-B08	M22x1.5		14		720B-08	14	21	38	25
1DL-24-B08	M24x1.5		16		720B-08	14	21	38	25
1DL-30-B12	M30x2		20		720B-12	16	26.5	46	31

备注:如需带卡套及卡套螺母整套订货,则请在代号后加"RN",如"1DL-20-B06/RN" (同上)

Remark: In case if you are interested to order the adapter in complete set with cutting ring and nut, it is necessary to insert suffix "RN" arter our part NO., for example 1DL-20-B06/RN. (the same with above)

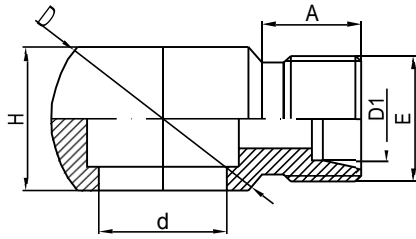

# 1CL

公制螺纹24°轻系列/ 公制螺纹铰接头  
METRIC MALE 24° L.T./METRIC BANJO

代号 PART NO.	螺纹 THREADE		管子外径 TUBE O.D.		配用螺栓 BOLT	尺寸 DIMENSIONS			
	E		D1			A	d	D	H
1CL-12-10	M12x1.5		6		700M-10	10	10	22	13
1CL-14-12	M14x1.5		8		700M-12	11	12	22	12
1CL-16-14	M16x1.5		10		700M-14	11	14	24	14
1CL-18-16	M18x1.5		12		700M-16	11.5	16	28	18
1CL-22-18	M22x1.5		15		700M-18	12.5	18	36	22
1CL-26-22	M26x1.5		18		700M-22	12	22	46	30

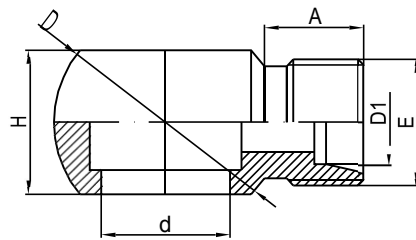

# 1DL

公制螺纹24°重系列/ 公制螺纹铰接头  
METRIC MALE 24° H.T./METRIC BANJO

代号 PART NO.	螺纹 THREADE		管子外径 TUBE O.D.		配用螺栓 BOLT	尺寸 DIMENSIONS			
	E		D1			A	d	D	H
1DL-14-12	M14x1.5		6		700M-12	12	12	22	12
1DL-16-14	M16x1.5		8		700M-14	12	14	24	14
1DL-18-16	M18x1.5		10		700M-16	12	16	28	18
1DL-20-18	M20x1.5		12		700M-18	12	18	36	22
1DL-22-18	M22x1.5		14		700M-18	14	20	36	22
1DL-24-22	M24x1.5		16		700M-22	14	22	46	30

备注:如需带卡套及卡套螺母整套订货,则请在代号后加"RN",如"1DL-22-18RN" (同上)  
Remark:In case if you are interested to order the adapter in complete set with cutting ring and nut,it is necessary to insert suffix"RN" arter our part NO.,for example 1DL-22-18RN. (the same with above)



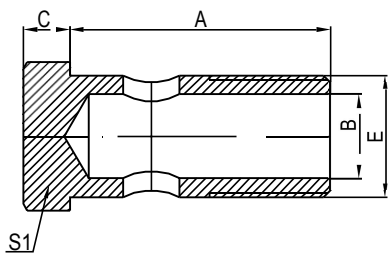

# 720B

英制铰接螺栓  
BSP BOLT

代号 PART NO.	螺纹 THREADE				尺寸 DIMENSIONS				
	E				A	B	C	S1	
720B-02	G1/8"-28				29.5	4.8	5	14	
720B-04	G1/4"-19				28.5	6	6	19	
720B-06	G3/8"-19				38.5	9	7	22	
720B-08	G1/2"-14				44	13	8.5	27	
720B-10	G5/8"-14				48.5	15	10	30	
720B-12	G3/4"-14				56	18	10	32	
720B-16	G1"-11				68.5	22	12.5	41	

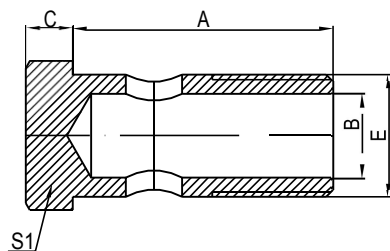

# 700M

公制铰接螺栓  
METRIC BOLT

代号 PART NO.	螺纹 THREADE				尺寸 DIMENSIONS				
	E				A	B	C	S1	
700M-10	M10x1				19	5	6	14	
700M-12	M12x1.5				24	6	6	17	
700M-14	M14x1.5				26	8	7	19	
700M-16	M16x1.5				28	9	7.5	22	
700M-18	M18x1.5				32	11	8	24	
700M-22	M22x1.5				39	14	9	27	
700M-26	M26x1.5				45	18	10	32	
700M-30	M30x2				51	22	11	38	

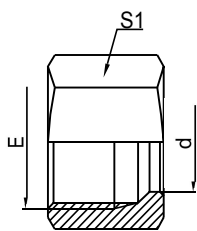

# NL

卡套螺母轻系列  
RETAINING NUTS L.T.

代号 PART NO.	螺纹 THREADE		管子外径 TUBE O.D.		尺寸 DIMENSIONS				
	E		D1		d	S1			
NL-12	M12x1.5		6		6	14			
NL-14	M14x1.5		8		8	17			
NL-16	M16x1.5		10		10	19			
NL-18	M18x1.5		12		12	22			
NL-22	M22x1.5		15		15	27			
NL-26	M26x1.5		18		18	32			
NL-30	M30x2		22		22	36			
NL-33	M33x2		25		25	41			
NL-36	M36x2		28		28	41			
NL-52	M52x2		42		42	60			

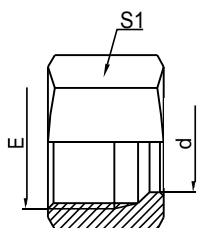

# NS

卡套螺母重系列  
RETAINING NUTS H.T.

代号 PART NO.	螺纹 THREADE		管子外径 TUBE O.D.		尺寸 DIMENSIONS				
	E		D1		d	S1			
NS-14	M14x1.5		6		6	17			
NS-16	M16x1.5		8		8	19			
NS-18	M18x1.5		10		10	22			
NS-20	M20x1.5		12		12	24			
NS-22	M22x1.5		14		14	27			
NS-24	M24x1.5		16		16	30			
NS-30	M30x2		20		20	36			
NS-36	M36x2		25		25	46			
NS-52	M52x2		38		38	60			

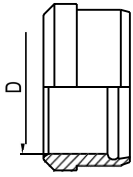

# RL

卡套轻系列  
CUTTING RING L.T.

代号 PART NO.	管子外径 TUBE O.D.								
			D1						
RL-06			6						
RL-08			8						
RL-10			10						
RL-12			12						
RL-15			15						
RL-18			18						
RL-22			22						
RL-28			28						
RL-35			35						
RL-42			42						

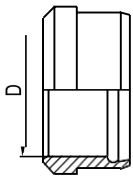

# RS

卡套重系列  
CUTTING RING H.T.

代号 PART NO.	管子外径 TUBE O.D.								
			D1						
RS-06			6						
RS-08			8						
RS-10			10						
RS-12			12						
RS-14			14						
RS-16			16						
RS-20			20						
RS-25			25						
RS-30			30						
RS-38			38						

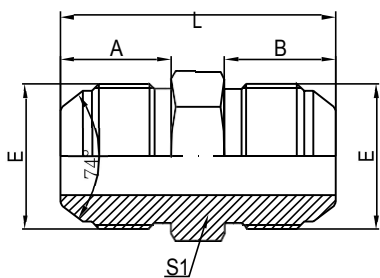

# 1Q

公制外螺纹74°外锥  
METRIC MALE 74° CONE

代号 PART NO.	螺纹 THREADE				尺寸 DIMENSIONS				
	E				A	B	S1		L
1Q-10	M10x1				12	12	12		30
1Q-12	M12x1.5				16	16	14		38
1Q-14	M14x1.5				17	17	17		40
1Q-16	M16x1.5				18	18	17		42
1Q-18	M18x1.5				18	18	19		42
1Q-22	M22x1.5				19.5	19.5	24		47
1Q-24	M24x1.5				20	20	27		49
1Q-27	M27x1.5				20	20	30		49
1Q-30	M30x1.5				23	23	32		56
1Q-30X2	M30x2				26	26	32		62
1Q-33	M33x2				26	26	36		63
1Q-36	M36x2				26	26	36		63
1Q-39	M39x2				26	26	41		64
1Q-42	M42x2				28.5	28.5	46		70
1Q-45	M45x2				28.5	28.5	46		70

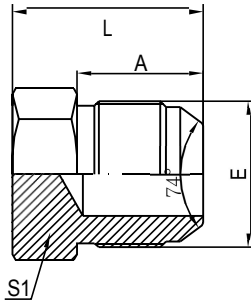

# 4Q

公制外螺纹74°外锥堵头  
METRIC MALE 74° CONE PLUG

代号 PART NO.	螺纹 THREADE				尺寸 DIMENSIONS				
	E				A		S1		L
4Q-10	M10x1				12		12		18
4Q-12	M12x1.5				16		14		22
4Q-14	M14x1.5				17		17		23
4Q-16	M16x1.5				18		17		24
4Q-18	M18x1.5				18		19		24
4Q-22	M22x1.5				19.5		24		27
4Q-24	M24x1.5				20		27		29
4Q-27	M27x1.5				20		30		29
4Q-30	M30x1.5				23		32		33
4Q-30E	M30x2				26		32		36
4Q-33	M33x2				26		36		37
4Q-36	M36x2				26		36		37
4Q-39	M39x2				26		41		38
4Q-42	M42x2				28.5		46		41.5
4Q-45	M45x2				28.5		46		41.5

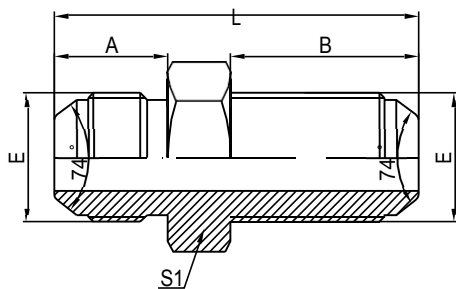

# 6Q

公制外螺纹74°外锥过板接头  
METRIC MALE 74° CONE BULKHEAD

代号 PART NO.	螺纹 THREADE				尺寸 DIMENSIONS				
	E				A	B	S1		L
6Q-10	M10x1				12	34	12		52
6Q-12	M12x1.5				16	38	14		60
6Q-14	M14x1.5				17	40	17		63
6Q-16	M16x1.5				18	41	17		65
6Q-18	M18x1.5				18	43	19		67
6Q-22	M22x1.5				19.5	44	24		71
6Q-24	M24x1.5				20	45	27		74
6Q-27	M27x1.5				20	48	30		77
6Q-30	M30x1.5				23	53	32		86
6Q-33	M33x2				26	55	36		92
6Q-36	M36x2				26	56	36		93
6Q-39	M39x2				26	58	41		96
6Q-42	M42x2				28.5	59	46		100.5
6Q-45	M45x2				28.5	60	46		101.5

备注:如需带锁母订货,则请在代号后加"LN",如6Q-18LN;

Remark:In case if you are interested to order the adapter with lock nut,please insert suffix"LN"after our part NO.,for example 6Q-18LN.

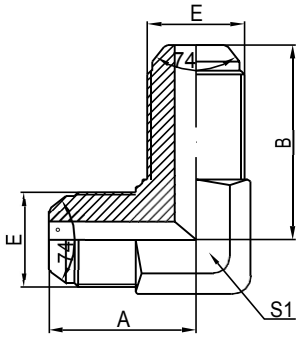

# 6Q9

90° 公制外螺纹74° 外锥过板接头  
90° METRIC MALE 74° CONE BULKHEAD

代号 PART NO.	螺纹 THREADE				尺寸 DIMENSIONS				
	E				A	B	S1		
6Q9-12	M12x1.5				25	56	11		
6Q9-14	M14x1.5				29	56	14		
6Q9-16	M16x1.5				30	58	17		
6Q9-18	M18x1.5				33	62	19		
6Q9-22	M22x1.5				37	64	22		
6Q9-27	M27x1.5				40	72	27		
6Q9-30	M30x1.5				40	72	27		
6Q9-33	M33x2				49	82	33		
6Q9-36	M36x2				46	82	33		
6Q9-39	M39x2				57	88	44		
6Q9-42	M42x2				57	88	44		
6Q9-45	M45x2				55	96	50		

备注:如需带锁母订货,则请在代号后加"LN",如6Q9-18LN;

Remark: In case if you are interested to order the adapter with lock nut, please insert suffix "LN" after our part NO., for example 6Q9-18LN.

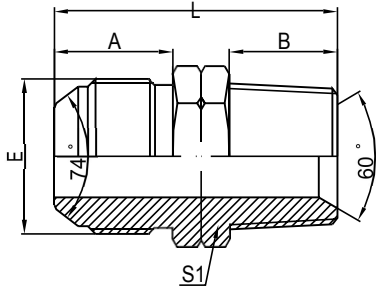

# 1QN

公制外螺纹74°外锥/ 布锥管外螺纹  
METRIC MALE 74° CONE/NPT MALE

代号 PART NO.	螺纹 THREADE		尺寸 DIMENSIONS				
	E	F	A	B	S1	L	
1QN-12-02	M12x1.5	Z1/8"X27	16	10	14	32	
1QN-12-04	M12x1.5	Z1/4"X18	16	14	14	36	
1QN-14-02	M14x1.5	Z1/8"X27	17	10	17	33	
1QN-14-04	M14x1.5	Z1/4"X18	17	14	17	37	
1QN-16-04	M16x1.5	Z1/4"X18	18	14	17	38	
1QN-16-06	M16x1.5	Z3/8"X18	18	14	17	38	
1QN-18-04	M18x1.5	Z1/4"X18	18	14	19	38	
1QN-18-06	M18x1.5	Z3/8"X18	18	14	19	38	
1QN-18-08	M18x1.5	Z1/2"X14	18	19	22	44	
1QN-22-06	M22x1.5	Z3/8"X18	19.5	14	24	41	
1QN-22-08	M22x1.5	Z1/2"X14	19.5	19	24	46	
1QN-27-06	M27x1.5	Z3/8"X18	20	14	30	43	
1QN-27-08	M27x1.5	Z1/2"X14	20	19	30	48	
1QN-27-12	M27x1.5	Z3/4"X14	20	19.5	30	48.5	
1QN-27-16	M27x1.5	Z1"X11.5	20	24	36	55	
1QN-30-12	M30x2	Z3/4"X14	23	19.5	32	52.5	
1QN-33-12	M33x2	Z3/4"X14	26	19.5	36	56.5	
1QN-36-16	M36x2	Z1"X11.5	25	24	41	61	
1QN-39-16	M39x2	Z1"X11.5	26	24	41	62	
1QN-45-16	M45x2	Z1"X11.5	28.5	24	46	65.5	
1QN-45-20	M45x2	Z1.1 / 4"X11.5	28.5	25	46	66.5	
1QN-45-24	M45x2	Z1.1 / 2"X11.5	28.5	25	50	70.5	
1QN-52-20	M52x2	Z1.1 / 4"X11.5	30	25	55	72	



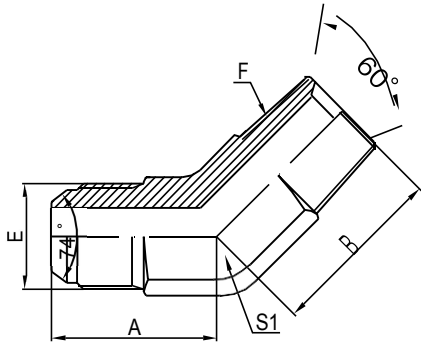

# 1QN4

45° 公制外螺纹 74° 外锥 / 布锥管外螺纹  
 45° METRIC MALE 74° CONE/NPT MALE

代号 PART NO.	螺纹 THREADE		尺寸 DIMENSIONS				
	E	F	A	B	S1		
1QN4-12-02	M12x1.5	Z1/8"X27	20	20	11		
1QN4-14-02	M14x1.5	Z1/8"X27	22	22	14		
1QN4-14-04	M14x1.5	Z1/4"X18	22	22	14		
1QN4-16-06	M16x1.5	Z3/8"X18	22	22	17		
1QN4-18-06	M18x1.5	Z3/8"X18	24	24	19		
1QN4-22-08	M22x1.5	Z1/2"X14	27	27	22		
1QN4-27-08	M27x1.5	Z1/2"X14	33	33	27		
1QN4-27-12	M27x1.5	Z3/4"X14	33	33	27		
1QN4-30-12	M30x1.5	Z3/4"X14	37	37	33		
1QN4-36-16	M36x2	Z1"X11.5	37	37	33		
1QN4-39-16	M39x2	Z1"X11.5	40	40	44		
1QN4-42-20	M42x2	Z1.1 / 4"X11.5	40	40	44		

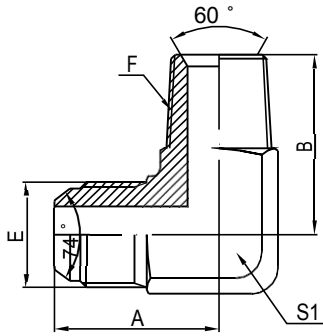

# 1QN9

90° 公制外螺纹 74° 外锥 / 布锥管外螺纹  
 90° METRIC MALE 74° CONE/NPT MALE

代号 PART NO.	螺纹 THREADS		尺寸 DIMENSIONS				
	E	F	A	B	S1		
1QN9-12-02	M12x1.5	Z1/8"X27	25	25	11		
1QN9-12-04	M12x1.5	Z1/4"X18	29	27	14		
1QN9-14-02	M14x1.5	Z1/8"X27	29	27	14		
1QN9-14-04	M14x1.5	Z1/4"X18	29	27	14		
1QN9-16-04	M16x1.5	Z1/4"X18	30	28	17		
1QN9-16-06	M16x1.5	Z3/8"X18	30	28	17		
1QN9-16-08	M16x1.5	Z1/2"X14	37	37	22		
1QN9-18-04	M18x1.5	Z1/4"X18	33	33	19		
1QN9-18-06	M18x1.5	Z3/8"X18	33	33	19		
1QN9-22-06	M22x1.5	Z3/8"X18	37	37	22		
1QN9-22-08	M22x1.5	Z1/2"X14	37	37	22		
1QN9-27-08	M27x1.5	Z1/2"X14	41	41	27		
1QN9-27-12	M27x1.5	Z3/4"X14	41	41	27		
1QN9-27-16	M27x1.5	Z1"X11.5	49	49	33		
1QN9-30-12	M30x1.5	Z3/4"X14	40	40	27		
1QN9-36-16	M36x2	Z1"X11.5	46	46	33		
1QN9-39-16	M39x2	Z1"X11.5	57	57	44		
1QN9-42-20	M42x2	Z1.1 / 4"X11.5	57	57	44		
1QN9-45-16	M45x2	Z1"X11.5	55	55	44		
1QN9-45-20	M45x2	Z1.1 / 4"X11.5	55	55	44		
1QN9-45-24	M45x2	Z1.1 / 2"X11.5	60	57	55		

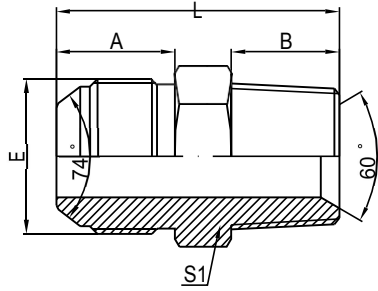

# 1QT

公制外螺纹74°外锥/英锥管外螺纹  
METRIC MALE 74° CONE/BSPT MALE

代号 PART NO.	螺纹 THREADE		尺寸 DIMENSIONS				
	E	F	A	B	S1	L	
1QT-12-02	M12x1.5	R1/8"X28	16	10	14	32	
1QT-12-04	M12x1.5	R1/4"X19	16	14	14	36	
1QT-14-02	M14x1.5	R1/8"X28	17	10	17	33	
1QT-14-04	M14x1.5	R1/4"X19	17	14	17	37	
1QT-16-04	M16x1.5	R1/4"X19	18	14	19	38	
1QT-16-06	M16x1.5	R3/8"X19	18	14	19	38	
1QT-18-04	M18x1.5	R1/4"X19	18	14	19	38	
1QT-18-06	M18x1.5	R3/8"X19	18	14	19	38	
1QT-18-08	M18x1.5	R1/2"X14	18	19	22	44	
1QT-22-06	M22x1.5	R3/8"X19	19.5	14	24	41	
1QT-22-08	M22x1.5	R1/2"X14	19.5	19	24	46	
1QT-27-06	M27x1.5	R3/8"X19	20	14	30	43	
1QT-27-08	M27x1.5	R1/2"X14	20	19	30	48	
1QT-27-12	M27x1.5	R3/4"X14	20	19.5	30	48.5	
1QT-27-16	M27x1.5	R1"X11	20	24	36	55	
1QT-30-12	M30x2	R3/4"X14	23	19.5	32	52.5	
1QT-33-12	M33x2	R3/4"X14	26	19.5	36	56.5	
1QT-36-16	M36x2	R1"X11	25	24	41	61	
1QT-39-16	M39x2	R1"X11	26	24	41	62	
1QT-45-16	M45x2	R1"X11	28.5	24	46	65.5	
1QT-45-20	M45x2	R1.1/4"X11	28.5	25	46	66.5	
1QT-45-24	M45x2	R1.1/2"X11	28.5	25	50	70.5	
1QT-52-20	M52x2	R1.1/4"X11	30	25	55	72	

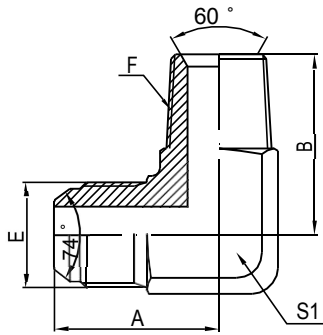

# 1QT9

90° 公制外螺纹74° 外锥/ 英锥管外螺纹  
 90° METRIC MALE 74° CONE/BSPT MALE

代号 PART NO.	螺纹 THREADE		尺寸 DIMENSIONS				
	E	F	A	B	S1		
1QT9-12-02	M12x1.5	R1/8"X28	25	25	11		
1QT9-12-04	M12x1.5	R1/4"X19	29	27	14		
1QT9-14-02	M14x1.5	R1/8"X28	29	27	14		
1QT9-14-04	M14x1.5	R1/4"X19	29	27	14		
1QT9-16-04	M16x1.5	R1/4"X19	30	28	17		
1QT9-16-06	M16x1.5	R3/8"X19	30	28	17		
1QT9-16-08	M16x1.5	R1/2"X14	37	37	22		
1QT9-18-04	M18x1.5	Z1/4"X19	33	33	19		
1QT9-18-06	M18x1.5	R3/8"X19	33	33	19		
1QT9-22-06	M22x1.5	R3/8"X19	37	37	22		
1QT9-22-08	M22x1.5	R1/2"X14	37	37	22		
1QT9-27-08	M27x1.5	R1/2"X14	41	41	27		
1QT9-27-12	M27x1.5	R3/4"X14	41	41	27		
1QT9-27-16	M27x1.5	R1"X11	49	49	33		
1QT9-30-12	M30x1.5	R3/4"X14	40	40	27		
1QT9-36-16	M36x2	R1"X11	46	46	33		
1QT9-39-16	M39x2	R1"X11	57	57	44		
1QT9-42-20	M42x2	R1.1/4"X11	57	57	44		
1QT9-45-16	M45x2	R1"X11	55	55	44		
1QT9-45-20	M45x2	R1.1/4"X11	55	55	44		
1QT9-45-24	M45x2	R1.1/2"X11	60	57	55		

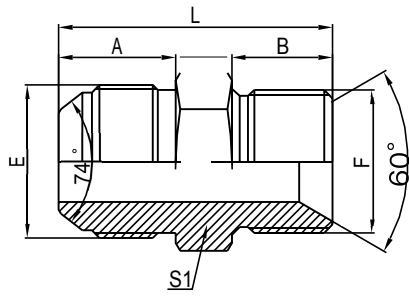

# 1QB

公制外螺纹74 ° 外锥/ 英管外螺纹  
 60 ° 内锥或六角端面组合垫密封  
 METRIC MALE 74 ° CONE/BSP MALE  
 DOUBLE FOR 60 ° SEAT BONDED SEAL

代号 PART NO.	螺纹 THREADE		尺寸 DIMENSIONS				
	E	F	A	B	S1	L	
1QB-12-02	M12x1.5	G1/8"X28	16	10	14	32	
1QB-14-04	M14x1.5	G1/4"X19	17	12	19	35	
1QB-16-06	M16x1.5	G3/8"X19	18	13.5	22	39	
1QB-18-06	M18x1.5	G3/8"X19	18	13.5	22	39	
1QB-22-08	M22x1.5	G1/2"X14	19.5	16	27	44	
1QB-24-10	M24x1.5	G5/8"X14	20	17.5	30	46.5	
1QB-27-12	M27x1.5	G3/4"X14	20	18.5	32	48.5	
1QB-30-12	M30x1.5	G3/4"X14	23	18.5	32	51.5	
1QB-30E-12	M30x2	G3/4"X14	26	18.5	32	54.5	
1QB-33-16	M33x2	G1"X11	26	20.5	41	58.5	
1QB-39-16	M39x2	G1"X11	26	20.5	41	58.5	
1QB-45-20	M45x2	G1.1/4"X11	28.5	20.5	50	66	

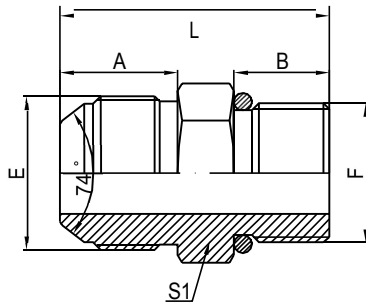

# 1QG

公制74°外锥/英管外螺纹O型圈  
METRIC 74° CONE/BSP MALE O-RING

代号 PART NO.	螺纹 THREADE		尺寸 DIMENSIONS				
	E	F	A	B	S1	L	
1QG-14-04	M14x1.5	G1/4"X19	17	12	17	35	
1QG-16-06	M16x1.5	G3/8"X19	18	13.5	22	39	
1QG-18-06	M18x1.5	G3/8"X19	18	13.5	22	39	
1QG-18-08	M18x1.5	G1/2"X14	18	16	27	43	
1QG-22-08	M22x1.5	G1/2"X14	19.5	16	27	44	
1QG-27-12	M27x1.5	G3/4"X14	20	18.5	32	48.5	
1QG-30-12	M30x1.5	G3/4"X14	23	18.5	32	51.5	
1QG-39-16	M39x2	G1"X11	26	20.5	41	58.5	
1QG-45-20	M45x2	G1.1/4"X11	28.5	20.5	50	66	

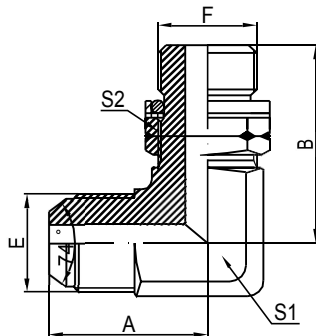

# 1QG9-OG

90°公制74°外锥/  
英管外螺纹O型圈可调向柱端  
90° METRIC 74° CONE/  
BSP MALE O-RING ADJUSTABLE STUD

代号 PART NO.	螺纹 THREADE		尺寸 DIMENSIONS				
	E	F	A	B	S1	S2	
1QG9-14-04OG	M14x1.5	G1/4"X19	27	31.3	14	19	
1QG9-16-06OG	M16x1.5	G3/8"X19	29	35.8	17	22	
1QG9-18-06OG	M18x1.5	G3/8"X19	32	36.8	19	22	
1QG9-18-08OG	M18x1.5	G1/2"X14	32	43.2	19	27	
1QG9-22-08OG	M22x1.5	G1/2"X14	37	43.2	22	27	
1QG9-27-12OG	M27x1.5	G3/4"X14	41	49.3	27	32	
1QG9-30-12OG	M30x1.5	G3/4"X14	40	52	27	32	
1QG9-39-16OG	M39x2	G1"X11	57	58	44	41	
1QG9-45-20OG	M45x2	G1.1/4"X11	55	63	44	50	

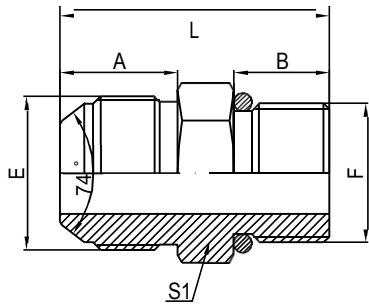

# 1QH

公制74°外锥/公制外螺纹  
METRIC 74° CONE/METRIC MALE

代号 PART NO.	螺纹 THREADE		尺寸 DIMENSIONS				
	E	F	A	B	S1	L	
1QH-14-12	M14x1.5	M12x1.5	17	11	17	34	
1QH-16-14	M16x1.5	M14x1.5	18	11	19	35	
1QH-18-16	M18x1.5	M16x1.5	18	11	22	36	
1QH-22-18	M22x1.5	M18x1.5	19.5	11	24	38	
1QH-27-22	M27x1.5	M22x1.5	20	12	27	41	
1QH-30-27	M30x1.5	M27x1.5	23	13	32	46	
1QH-33-27	M33x2	M27x1.5	26	13	32	49	

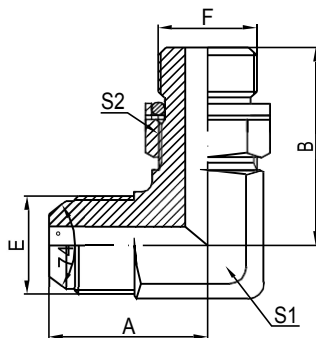

# 1QH9-OG

90°公制74°外锥/  
公制外螺纹可调向柱端  
90° METRIC 74° CONE/  
METRIC MALE ADJUSTABLE STUD

代号 PART NO.	螺纹 THREADE		尺寸 DIMENSIONS				
	E	F	A	B	S1	S2	
1QH9-14-12OG	M14x1.5	M12x1.5	27	32	14	17	
1QH9-16-14OG	M16x1.5	M14x1.5	29	35.5	17	19	
1QH9-18-16OG	M18x1.5	M16x1.5	32	36	19	22	
1QH9-22-18OG	M22x1.5	M18x1.5	37	39.5	22	24	
1QH9-27-22OG	M27x1.5	M22x1.5	41	43.5	27	27	
1QH9-30-27OG	M30x1.5	M27x1.5	40	50	27	32	
1QH9-33-27OG	M33x2	M27x1.5	49	52	33	32	
1QH9-36-33OG	M36x2	M33x2	49	54	33	41	
1QH9-39-33OG	M39x2	M33x2	57	57.2	44	41	
1QH9-45-42OG	M45x2	M42x2	55	61	44	50	

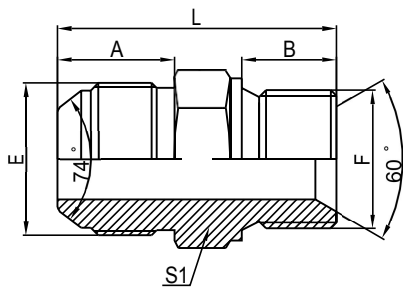

# 1QM

公制外螺纹74°外锥/公制外螺纹  
60°内锥或六角端面组合垫密封  
METRIC MALE 74° CONE/METRIC MALE  
DOUBLE FOR 60° SEAT BONDED SEAL

代号 PART NO.	螺纹 THREADE		尺寸 DIMENSIONS				
	E	F	A	B	S1	L	
1QM-12	M12x1.5	M12x1.5	16	10	17	34	
1QM-14	M14x1.5	M14x1.5	17	11	19	36	
1QM-14-12	M14x1.5	M12x1.5	17	10	17	35	
1QM-14-16	M14x1.5	M16x1.5	17	12	22	38	
1QM-16	M16x1.5	M16x1.5	18	12	22	39	
1QM-16-14	M16x1.5	M14x1.5	18	11	19	37	
1QM-18	M18x1.5	M18x1.5	18	12	24	40	
1QM-18-16	M18x1.5	M16x1.5	18	12	22	39	
1QM-22	M22x1.5	M22x1.5	19.5	14	27	44.5	
1QM-22-18	M22x1.5	M18x1.5	19.5	12	24	39	



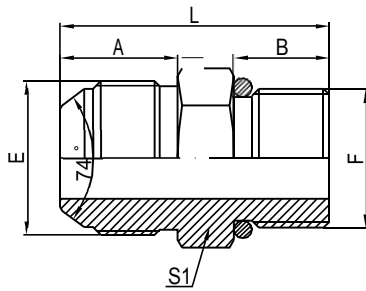

# 1QO

公制外螺纹74°外锥/  
SAE外螺纹O型圈  
METRIC MALE74°CONE/  
SAE MALE O-RING

代号 PART NO.	螺纹 THREADE		尺寸 DIMENSIONS				
	E	F	A	B	S1	L	
1QO-16-06	M16x1.5	U9 / 16"X18	18	12	17	36	
1QO-18-08	M18x1.5	U3 / 4"X16	18	12	22	37	
1QO-22-10	M22x1.5	U7 / 8"X14	19.5	13.5	27	42	
1QO-27-12	M27x1.5	U1.1 / 16"X12	20	16	32	46	
1QO-30-12	M30x1.5	U1.1 / 16"X12	23	16	32	49	
1QO-33-16	M33x2	U1.5 / 16"X12	26	17	41	55	
1QO-39-16	M39x2	U1.5 / 16"X12	26	17	41	55	
1QO-42-20	M42x2	U1.5 / 8"X12	28.5	18	50	63.5	

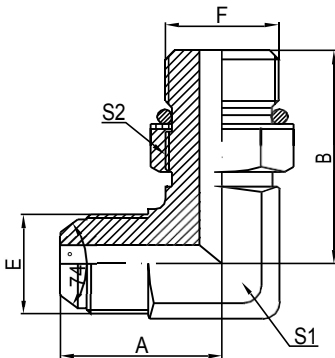

# 1QO9-OG

90°公制外螺纹74°外锥/  
SAE外螺纹O型圈90°  
METRIC MALE74°CONE/  
SAE MALE O-RING ADJUSTABLE STUD

代号 PART NO.	螺纹 THREADE		尺寸 DIMENSIONS				
	E	F	A	B	S1	S2	
1QO9-16-06OG	M16x1.5	U9/16"X18	30	31.8	17	19	
1QO9-18-08OG	M18x1.5	U3/4"X16	37	36.8	22	24	
1QO9-22-10OG	M22x1.5	U7/8"X14	37	44	22	27	
1QO9-27-12OG	M27x1.5	U1.1 / 16"X12	41	51	27	32	
1QO9-30-12OG	M30x1.5	U1.1 / 16"X12	40	53	27	32	
1QO9-33-16OG	M33x2	U1.5 / 16"X12	49	54.5	33	41	
1QO9-39-16OG	M39x2	U1.5 / 16"X12	49	59.5	44	41	
1QO9-42-20OG	M42x2	U1.5 / 8"X12	49	59	44	50	

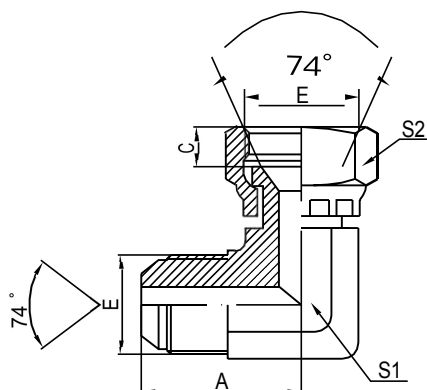

## 2Q9

90° 公制外螺纹74° 外锥/  
公制内螺纹74° 内锥90°  
METRIC MALE 74° CONE/  
METRIC FEMALE 74° SEAT

代号 PART NO.	螺纹 THREADE				尺寸 DIMENSIONS				
	E				A	C	S1	S2	
2Q9-14	M14x1.5				29	9	14	19	
2Q9-16	M16x1.5				30	9.5	17	22	
2Q9-18	M18x1.5				33	9.5	19	24	
2Q9-22	M22x1.5				37	10	22	27	
2Q9-27	M27x1.5				41	10.5	27	32	
2Q9-30	M30x1.5				40	11.5	27	36	
2Q9-33	M33x2				49	14.5	33	41	
2Q9-36	M36x2				46	13.5	33	41	
2Q9-39	M39x2				57	13.5	44	46	
2Q9-45	M52x2				55	15.5	44	55	

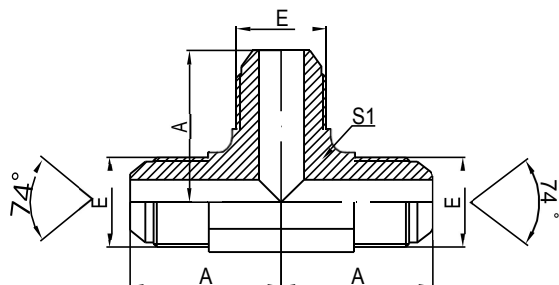

## AQ

公制外螺纹74° 外锥三通  
METRIC MALE 74° CONE TEE

代号 PART NO.	螺纹 THREADE				尺寸 DIMENSIONS				
	E				A		S1		
AQ-14	M14x1.5				27		14		
AQ-16	M16x1.5				29		17		
AQ-18	M18x1.5				32		19		
AQ-22	M22x1.5				33		22		
AQ-27	M27x1.5				40		27		
AQ-30	M30x1.5				40		27		
AQ-33	M33x2				49		33		

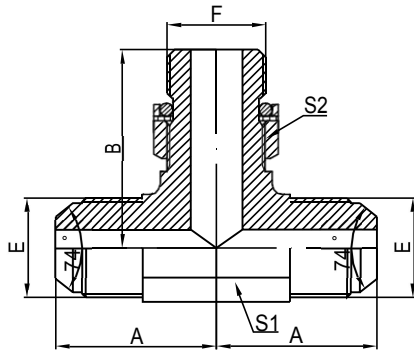

# AQH-Q-OG

公制外螺纹74°外锥/  
可调向柱端分支三通  
METRIC MALE 74° CONE/  
ADJUSTABLE STUD BRANCH TEE

代号 PART NO.	螺纹 THREADE		O型圈 O-RING	尺寸 DIMENSIONS			
	E	F		A	B	S1	S2
AQH-Q-14-12-140G	M14x1.5	M12x1.5	9.3x2.4	27	32	14	17
AQH-Q-16-14-160G	M16x1.5	M14x1.5	11.3x2.4	29	35.5	17	19
AQH-Q-18-16-180G	M18x1.5	M16x1.5	13.3x2.4	32	36	19	22
AQH-Q-22-18-220G	M22x1.5	M18x1.5	15.3x2.4	33	39.5	22	24
AQH-Q-27-22-270G	M27x1.5	M22x1.5	19.3x2.4	40	43.5	27	27
AQH-Q-30-27-300G	M30x1.5	M27x1.5	23.5x3	40	50	27	32
AQH-Q-33-27-330G	M33x2	M27x1.5	23.5x3	49	52	33	32
AQH-Q-36-33-360G	M36x2	M33x2	29.5x3	46	54	33	41
AQH-Q-39-33-390G	M39x2	M33x2	29.5x3	57	57.2	44	41

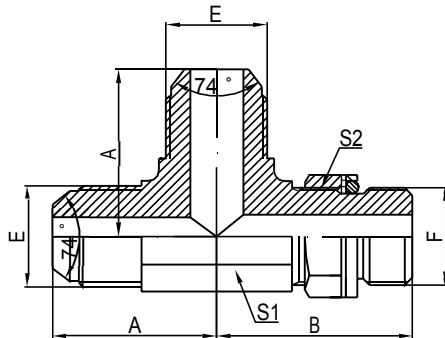

# AQQH-OG

公制外螺纹74°外锥/  
可调向柱端主支三通  
METRIC MALE 74° CONE/  
ADJUSTABLE STUD RUN TEE

代号 PART NO.	螺纹 THREADE		O型圈 O-RING	尺寸 DIMENSIONS			
	E	F		A	B	S1	S2
AQQH-14-14-120G	M14x1.5	M12x1.5	9.3x2.4	27	32	14	17
AQQH-16-16-140G	M16x1.5	M14x1.5	11.3x2.4	29	35.5	17	19
AQQH-18-18-160G	M18x1.5	M16x1.5	13.3x2.4	32	36	19	22
AQQH-22-22-180G	M22x1.5	M18x1.5	15.3x2.4	33	39.5	22	24
AQQH-27-27-220G	M27x1.5	M22x1.5	19.3x2.4	40	43.5	27	27
AQQH-30-30-270G	M30x1.5	M27x1.5	23.5x3	40	50	27	32
AQQH-33-33-270G	M33x2	M27x1.5	23.5x3	49	52	33	32
AQQH-36-36-330G	M36x2	M33x2	29.5x3	36	54	33	41
AQQH-39-39-330G	M39x2	M33x2	29.5x3	57	57.2	44	41

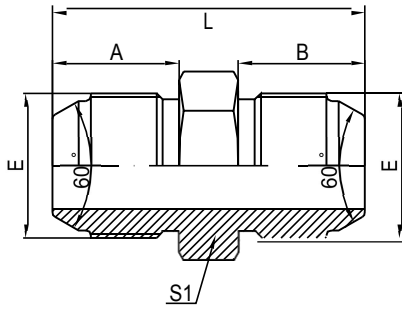

# 1K

日本公制外螺纹60°外锥  
JIS METRIC MALE60° CONE

代号 PART NO.	螺纹 THREADE				尺寸 DIMENSIONS				
	E				A	B	S1		L
1K-14	M14x1.5				17	17	17		40
1K-16	M16x1.5				18	18	17		42
1K-18	M18x1.5				18	18	19		42
1K-20	M20x1.5				20	20	22		47
1K-22	M22x1.5				20	20	24		48
1K-24	M24x1.5				21.5	21.5	27		52
1K-30	M30x1.5				26	26	32		62
1K-33	M33x1.5				30	30	36		71
1K-36	M36x1.5				33	33	41		78
1K-42	M42x1.5				36	36	46		85

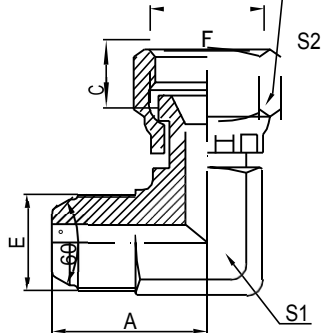

# 2K9

90°日本公制螺纹60°外锥  
90° JIS METRIC MALE60° CONE

代号 PART NO.	螺纹 THREADE			尺寸 DIMENSIONS				
	E	F		A	C	S1	S2	
2K9-14	M14x1.5	M14x1.5		29	12	14	19	
2K9-16	M16x1.5	M16x1.5		30	9.5	17	22	
2K9-18	M18x1.5	M18x1.5		33	11	19	24	
2K9-22	M22x1.5	M22x1.5		37	14	22	27	
2K9-24	M24x1.5	M24x1.5		37	13.5	24	32	
2K9-30-24	M30x1.5	M24x1.5		40	13.5	27	32	
2K9-30	M30x1.5	M30x1.5		40	20	27	36	
2K9-33	M33x1.5	M33x1.5		49	20.5	33	41	

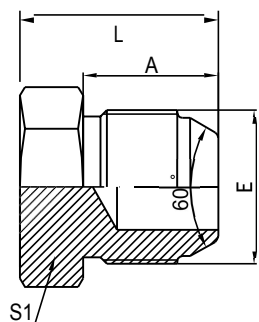

# 4K

日本公制外螺纹60°外锥堵头  
JIS METRIC MALE 60° CONE PLUG

代号 PART NO.	螺纹 THREADE				尺寸 DIMENSIONS				
	E				A		S1		L
4K-14	M14x1.5				17		14		23
4K-16	M16x1.5				18		17		24
4K-18	M18x1.5				18		19		24
4K-20	M20x1.5				20		22		27
4K-22	M22x1.5				20		24		28
4K-24	M24x1.5				21.5		27		30
4K-30	M30x1.5				26		32		36
4K-33	M33x1.5				30		36		41

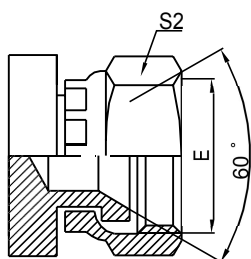

# 9K

日本公制内螺纹内锥60°  
JIS METRIC FEMALE 60° SEAT PLUG

代号 PART NO.	螺纹 THREADE				尺寸 DIMENSIONS				
	E				C	S1	S2		
9K-14	M14x1.5				12	19	19		
9K-16	M16x1.5				9.5	19	22		
9K-18	M18x1.5				11	24	24		
9K-22	M22x1.5				14	27	27		
9K-24	M24x1.5				13.5	32	32		
9K-30	M30x1.5				20	36	36		
9K-33	M33x1.5				20.5	41	41		

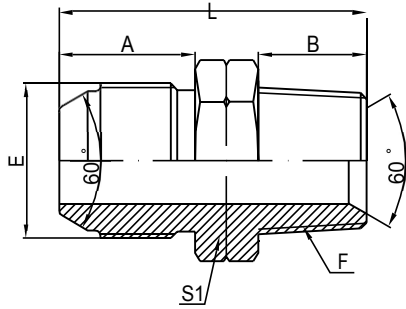

# 1KN

日本公制外螺纹60°外锥/ 布锥管外螺纹  
JIS METRIC MALE 60° CONE/NPT MALE

代号 PART NO.	螺纹 THREADS		尺寸 DIMENSIONS				
	E	F	A	B	S1	L	
1KN-14-04	M14x1.5	Z1/4"X18	17	14	14	37	
1KN-14-06	M14x1.5	Z3/8"X18	17	14	17	37	
1KN-16-06	M16x1.5	Z3/8"X18	18	14	17	38	
1KN-18-06	M18x1.5	Z3/8"X18	18	14	19	38	
1KN-20-06	M20x1.5	Z3/8"X18	20	14	22	41	
1KN-22-06	M22x1.5	Z3/8"X18	20	14	24	42	
1KN-22-08	M22x1.5	Z1/2"X14	20	19	24	47	
1KN-24-12	M24x1.5	Z3/4"X14	21.5	19.5	27	50	
1KN-30-12	M30x1.5	Z3/4"X14	26	19.5	32	55.5	
1KN-33-16	M33x1.5	Z1"X11.5	30	24	36	65	
1KN-36-20	M36x1.5	Z1.1/4"X11.5	33	25	46	71	
1KN-42-24	M42x1.5	Z1.1/2"X11.5	36	25	50	78	

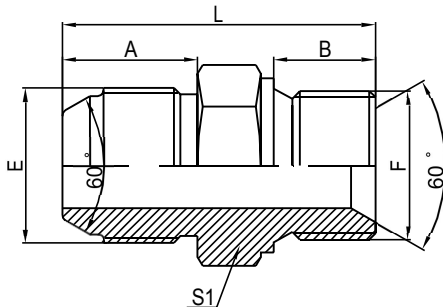

# 1KM

日本公制外螺纹60°外锥/  
公制外螺纹60°密封或组合垫圈  
JIS METRIC MALE 60° CONE/  
METRIC MALE 60° CONE BONDED SEAL

代号 PART NO.	螺纹 THREADS		尺寸 DIMENSIONS				
	E	F	A	B	S1	L	
1KM-14-12	M14x1.5	M12x1.5	17	10	17	35	
1KM-14	M14x1.5	M14x1.5	17	11	19	36	
1KM-22-16	M22x1.5	M16x1.5	20	12	22	41	
1KM-22-18	M22x1.5	M18x1.5	20	12	24	42	
1KM-22	M22x1.5	M22x1.5	20	14	27	45	

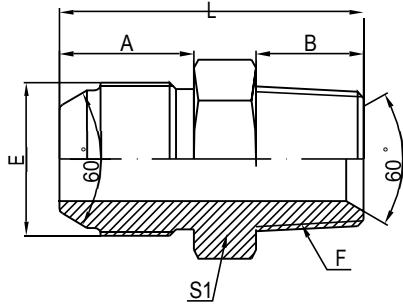

# 1KT

日本公制外螺纹60° / 英锥管外螺纹  
JIS METRIC MALE60° CONE/BSPT MALE

代号 PART NO.	螺纹 THREADE		尺寸 DIMENSIONS				
	E	F	A	B	S1	L	
1KT-14-04	M14x1.5	R1/4"X19	17	14	17	37	
1KT-16-06	M16x1.5	R3/8"X19	18	14	19	38	
1KT-18-06	M18x1.5	R3/8"X19	18	14	19	38	
1KT-22-06	M22x1.5	R3/8"X19	20	14	24	42	
1KT-22-08	M22x1.5	R1/2"X14	20	19	24	47	
1KT-30-12	M30x1.5	R3/4"X14	26	19.5	32	55.5	
1KT-33-16	M33x1.5	R1"X11	30	24	36	65	
1KT-36-20	M36x1.5	R1.1/4"X11	33	25	46	71	
1KT-42-24	M42x1.5	R1.1/2"X11	36	25	50	78	

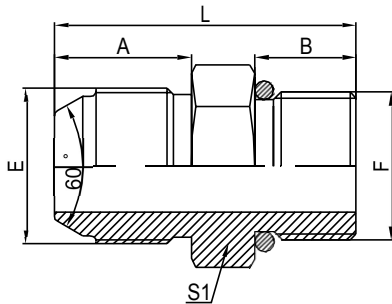

# 1KH

日本公制外螺纹60° 外锥/  
公制外螺纹重系列  
JIS METRIC MALE60° CONE/  
METRIC MALE S-SERIES

代号 PART NO.	螺纹 THREADE		尺寸 DIMENSIONS				
	E	F	A	B	S1	L	
1KH-14-12	M14x1.5	M12x1.5	17	11	17	34	
1KH-14	M14x1.5	M14x1.5	17	11	19	34	
1KH-16-14	M16x1.5	M14x1.5	18	11	19	35	
1KH-18-14	M18x1.5	M14x1.5	18	11	19	35	
1KH-18-16	M18x1.5	M16x1.5	18	11	22	36	
1KH-18-20	M18x1.5	M20x1.5	18	12	27	39	
1KH-20-18	M20x1.5	M18x1.5	20	11	24	39	
1KH-22-20	M22x1.5	M20x1.5	20	12	27	41	
1KH-24-20	M24x1.5	M20x1.5	21.5	12	27	42	
1KH-24-22	M24x1.5	M22x1.5	21.5	12	27	42	
1KH-30-27	M30x1.5	M27x1.5	26	13	32	49	

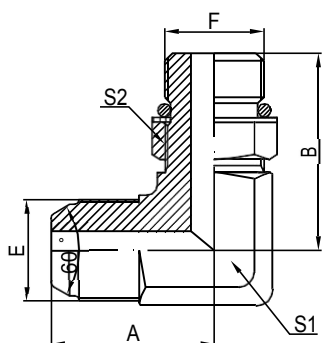

# 1KH9-OG

90° 日本公制外螺纹60° 外锥/  
公制外螺纹可调向柱端 90° JIS  
METRIC MALE 60° CONE/ METRIC  
ALE ADJUSTABLE STUD

代号 PART NO.	螺纹 THREADE				O型圈 O-RING	尺寸 DIMENSIONS			
	E	F				A	B	S1	S2
1KH9-14-12OG	M14x1.5	M12x1.5			9.3x2.4	27	33.5	14	17
1KH9-14OG	M14x1.5	M14x1.5			11.3x2.4	27	34.5	14	19
1KH9-16-14OG	M16x1.5	M14x1.5			11.3x2.4	29	35.5	17	19
1KH9-18-14OG	M18x1.5	M14x1.5			11.3x2.4	32	37.5	19	19
1KH9-18-16OG	M18x1.5	M16x1.5			13.3x2.4	32	39.5	19	22
1KH9-18-20OG	M18x1.5	M20x1.5			17.3x2.4	37	44	22	27
1KH9-20-18OG	M20x1.5	M18x1.5			15.3x2.4	37	42.5	22	24
1KH9-22-20OG	M22x1.5	M20x1.5			17.3x2.4	37	45.5	22	27
1KH9-24-20OG	M24x1.5	M20x1.5			17.3x2.4	37	47	24	27
1KH9-24-22OG	M24x1.5	M22x1.5			19.3x2.4	37	47	24	27
1KH9-30-27OG	M30x1.5	M27x1.5			23.5x3	40	57	27	32
1KH9-33OG	M33x1.5	M33x1.5			29.5x3	49	59	33	41
1KH9-36-33OG	M36x1.5	M33x1.5			29.5x3	46	60.5	33	41



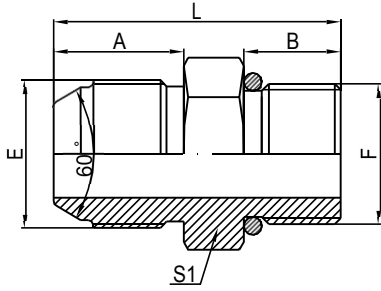

# 1KG

日本公制外螺纹60°外锥/  
英管外螺纹O型圈  
JIS METRIC MALE 60° CONE/  
BSP MALE O-RING

代号 PART NO.	螺纹 THREADE		尺寸 DIMENSIONS				
	E	F	A	B	S1	L	
1KG-14-04	M14x1.5	G1/4"X19	17	12	19	35	
1KG-14-06	M14x1.5	G3/8"X19	17	13.5	22	38	
1KG-16-06	M16x1.5	G3/8"X19	18	13.5	22	39	
1KG-18-06	M18x1.5	G3/8"X19	18	13.5	22	39	
1KG-22-08	M22x1.5	G1/2"X14	20	16	27	45	
1KG-30-12	M30x1.5	G3/4"X14	26	18.5	32	54.5	
1KG-33-12	M33x1.5	G3/4"X14	30	18.5	36	59.5	
1KG-33-16	M33x1.5	G1"X11	30	20.5	41	62.5	

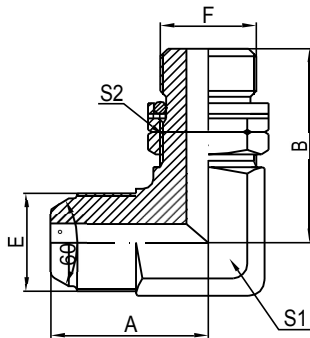

# 1KG9-OG

90°日本公制外螺纹60°/  
英管外螺纹O型圈可调向柱端  
90°JIS METRIC MALE/  
BSP MALE O-RING ADJUSTABLE STUD

代号 PART NO.	螺纹 THREADE		尺寸 DIMENSIONS			
	E	F	A	B	S1	S2
1KG9-14-04OG	M14x1.5	G1/4"X19	29	31.3	14	19
1KG9-14-06OG	M14x1.5	G3/8"X19	30	35.8	17	22
1KG9-16-06OG	M16x1.5	G3/8"X19	30	35.8	17	22
1KG9-18-06OG	M18x1.5	G3/8"X19	33	37	19	22
1KG9-22-08OG	M22x1.5	G1/2"X14	37	43.2	22	27
1KG9-24-08OG	M24x1.5	G1/2"X14	37	46	24	27
1KG9-24-12OG	M24x1.5	G3/4"X14	41	49.3	27	32
1KG9-30-12OG	M30x1.5	G3/4"X14	40	53	27	32
1KG9-33-16OG	M33x1.5	G1"X11	49	53	33	41
1KG9-42-20OG	M42x1.5	G1.1/4"X11	57	59	44	50

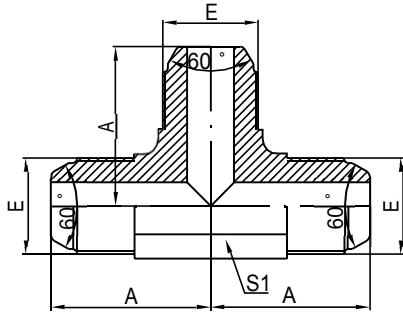

# AK

日本公制外螺纹60°外锥三通  
JIS METRIC MALE 60° CONE TEE

代号 PART NO.	螺纹 THREADE				尺寸 DIMENSIONS			
	E				A		S1	
AK-14	M14x1.5				27		14	
AK-16	M16x1.5				29		17	
AK-18	M18x1.5				32		19	
AK-22	M22x1.5				33		22	
AK-24	M24x1.5				33		24	
AK-30	M30x1.5				40		27	
AK-33	M33x1.5				49		33	

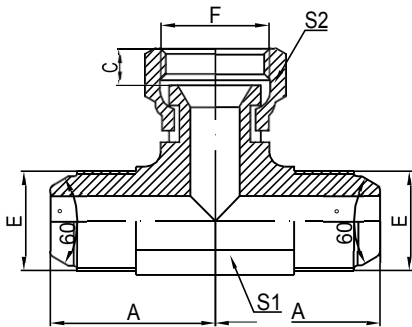

# BK

日本公制外螺纹60°外锥/  
日本公制内螺纹60°内锥分支三通  
JIS METRIC MALE 60° CONE/  
JIS METRIC FEMALE 60° SEAT BRANCH TEE

代号 PART NO.	螺纹 THREADE				尺寸 DIMENSIONS			
	E	F			A	C	S1	S2
BK-14	M14x1.5	M14x1.5			27	12	14	19
BK-16	M16x1.5	M16x1.5			29	9.5	17	22
BK-18	M18x1.5	M18x1.5			32	11	19	24
BK-22	M22x1.5	M22x1.5			33	14	22	27
BK-24	M24x1.5	M24x1.5			33	13.5	24	32
BK-30	M30x1.5	M30x1.5			40	20	27	36
BK-33	M33x1.5	M33x1.5			49	20.5	33	41

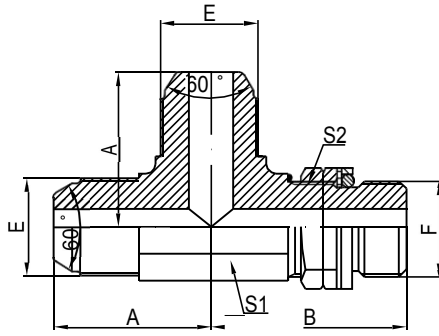

# AKKG-OG

日本公制外螺纹/ 英管外螺纹  
 O型圈可调向柱端主支三通  
 JIS METRIC MALE/BSP MALE O-RING  
 RUN TEE ADJUSTABLE STUD

代号 PART NO.	螺纹 THREADE		尺寸 DIMENSIONS				
	E	F	A	B	S1	S2	
AKKG-14-14-040G	M14x1.5	G1/4"X19	27	31.3	14	19	
AKKG-14-14-060G	M14x1.5	G3/8"X19	29	35.8	17	22	
AKKG-16-16-060G	M16x1.5	G3/8"X19	29	35.8	17	22	
AKKG-18-18-060G	M18x1.5	G3/8"X19	32	37	19	22	
AKKG-22-22-080G	M22x1.5	G1/2"X14	33	43.2	22	27	
AKKG-24-24-080G	M24x1.5	G1/2"X14	33	46	24	27	
AKKG-24-24-120G	M24x1.5	G3/4"X14	40	49.3	27	32	
AKKG-30-30-120G	M30x1.5	G3/4"X14	40	53	27	32	
AKKG-33-33-160G	M33x1.5	G1"X11	49	53	33	41	

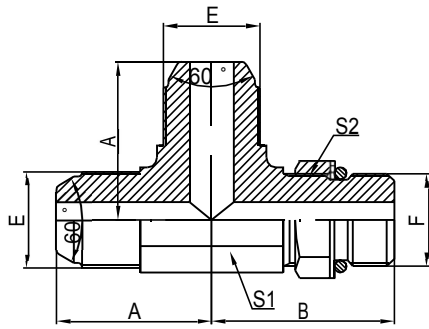

# AKKH-OG

日本公制外螺纹60°外锥/公制外  
螺纹可调向柱端主支三通  
JIS METRIC MALE 60° CONE/  
ADJUSTABLE STUD RUN TEE

代号 PART NO.	螺纹 THREADE		O型圈 O-RING	尺寸 DIMENSIONS				
	E	F		A	B	S1	S2	
AKKH-14-14-12OG	M14x1.5	M12x1.5	9.3x2.4	27	33.5	14	17	
AKKH-14OG	M14x1.5	M14x1.5	11.3x2.4	27	34.5	14	19	
AKKH-16-16-14OG	M16x1.5	M14x1.5	11.3x2.4	29	35.5	17	19	
AKKH-18-18-16OG	M18x1.5	M16x1.5	13.3x2.4	32	39.5	19	22	
AKKH-18-18-20OG	M18x1.5	M20x1.5	17.3x2.4	33	44	22	27	
AKKH-20-20-18OG	M20x1.5	M18x1.5	15.3x2.4	33	42.5	22	24	
AKKH-22-22-20OG	M22x1.5	M20x1.5	17.3x2.4	33	45.5	22	27	
AKKH-24-24-20OG	M24x1.5	M20x1.5	17.3x2.4	33	47	24	27	
AKKH-24-24-22OG	M24x1.5	M22x1.5	19.3x2.4	33	47	24	27	
AKKH-30-30-27OG	M30x1.5	M27x1.5	23.5x3	40	57	27	32	
AKKH-33OG	M33x1.5	M33x1.5	29.5x3	49	59	33	41	
AKKH-36-36-33OG	M36x1.5	M33x1.5	29.5x3	46	60.5	33	41	

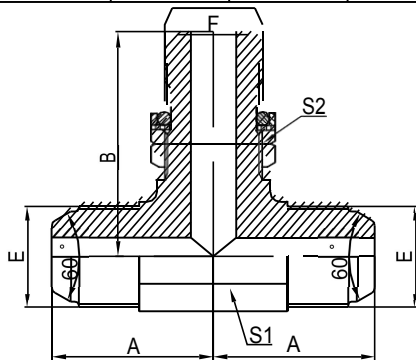

# AKGK-OG

日本公制外螺纹/英管外螺  
纹O型圈可调向柱端分支三通  
JIS METRIC MALE/BSP MALE O-RING  
ADJUSTABLE STUD BRANCH TEE

代号 PART NO.	螺纹 THREADE		O型圈 O-RING	尺寸 DIMENSIONS				
	E	F		A	B	S1	S2	
AKGK-14-04-14OG	M14x1.5	G1/4"X19		27	31.3	14	19	
AKGK-14-06-14OG	M14x1.5	G3/8"X19		29	35.8	17	22	
AKGK-16-06-16OG	M16x1.5	G3/8"X19		29	35.8	17	22	
AKGK-18-06-18OG	M18x1.5	G3/8"X19		32	37	19	22	
AKGK-22-08-22OG	M22x1.5	G1/2"X14		33	43.2	22	27	
AKGK-24-08-24OG	M24x1.5	G1/2"X14		33	46	24	27	
AKGK-24-12-24OG	M24x1.5	G3/4"X14		40	49.3	27	32	
AKGK-30-12-30OG	M30x1.5	G3/4"X14		40	53	27	32	
AKGK-33-16-33OG	M33x1.5	G1"X11		49	53	33	41	

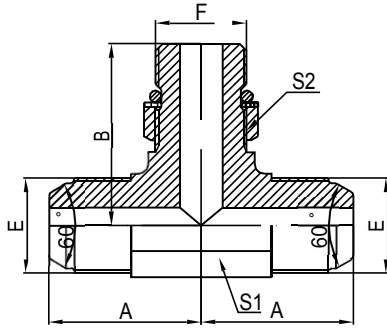

# AKHK-OG

日本公制外螺纹60°外锥/公制外  
 螺纹可调向柱端分支三通  
 JIS METRIC MALE 60° CONE/  
 ADJUSTABLE STUD BRANCHTEE

代号 PART NO.	螺纹 THREADE			O型圈 O-RING	尺寸 DIMENSIONS				
	E	F			A	B	S1	S2	
AKHK-14-12-14OG	M14x1.5	M12x1.5		9.3x2.4	27	33.5	14	17	
AKHK-14OG	M14x1.5	M14x1.5		11.3x2.4	27	34.5	14	19	
AKHK-16-14-16OG	M16x1.5	M14x1.5		11.3x2.4	29	35.5	17	19	
AKHK-18-14-18OG	M18x1.5	M14x1.5		11.3x2.4	32	37.5	19	19	
AKHK-18-16-18OG	M18x1.5	M16x1.5		13.3x2.4	32	39.5	19	22	
AKHK-18-20-18OG	M18x1.5	M20x1.5		17.3x2.4	33	44	22	27	
AKHK-20-18-20OG	M20x1.5	M18x1.5		15.3x2.4	33	42.5	22	24	
AKHK-22-20-22OG	M22x1.5	M20x1.5		17.3x2.4	33	45.5	22	27	
AKHK-24-20-24OG	M24x1.5	M20x1.5		17.3x2.4	33	47	24	27	
AKHK-24-22-24OG	M24x1.5	M22x1.5		19.3x2.4	33	47	24	27	
AKHK-30-27-30OG	M30x1.5	M27x1.5		23.5x3	40	57	27	32	
AKHK-33OG	M33x1.5	M33x1.5		29.5x3	49	59	33	41	

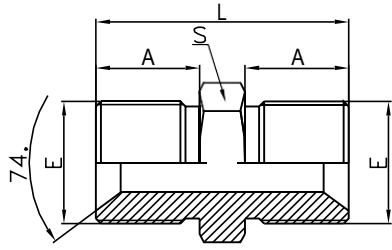

# 1V

公制外螺纹74°内锥面  
METRIC FEMALE 74° CONE SEAT

代号 PART NO.	螺纹E THREADE		尺寸 DIMENSIONS			
	E		A	S	L	
1V-14	M14X1.5		8	14	22	
1V-16	M16X1.5		8.5	17	23	
1V-18	M18X1.5		8.5	19	23	
1V-22	M22X1.5		9	24	26	
1V-27	M27X1.5		8.5	30	26	
1V-30	M30X1.5		8	32	26	
1V-36	M36X2		9	41	30	
1V-39	M39X2		9	41	30	
1V-45	M45X2		9	46	31	
1V-52	M52X2		9	55	35	
1V-64	M64X2		12	65	41	

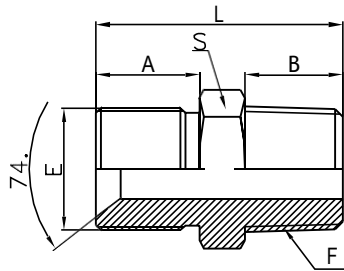

# 1VT

公制外螺纹74°内锥面/ 英锥管外螺纹  
METRIC FEMALE 74° CONE SEAT/BSPT MALE

代号 PART NO.	螺纹E THREADE		尺寸 DIMENSIONS			
	E	F	A	B	S	L
1VT-14-04	M14X1.5	ZG1/4"-19	8	14	14	28
1VT-18-06	M18X1.5	ZG3/8"-19	8.5	14	19	28.5
1VT-22-08	M22X1.5	ZG1/2"-14	9	19	24	36
1VT-30-12	M30X1.5	ZG3/4"-14	8	19.5	32	37.5
1VT-39-16	M39X2	ZG1"-11	9	24	41	45
1VT-45-20	M45X2	ZG1.1/4"-11	9	25	46	47
1VT-52-24	M52X2	ZG1.1/2"-11	9	25	55	51
1VT-64-32	M64X2	ZG2"-11	12	29	65	58

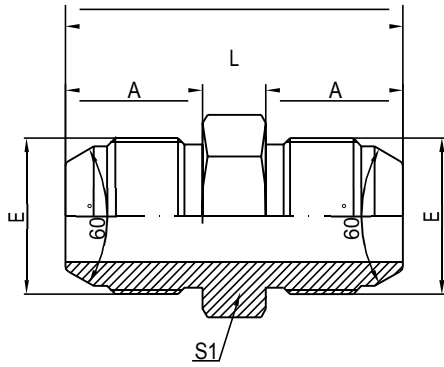

# 1S

日本英管外螺纹60°外锥  
JIS GAS MALE 60° CONE

代号 PART NO.	螺纹 THREADE				尺寸 DIMENSIONS				
	E				A		S1		L
1S-04	G1/4"X19				15		14		36
1S-06	G3/8"X19				16		17		38
1S-08	G1/2"X14				19		22		45
1S-12	G3/4"X14				23		30		55
1S-16	G1"X11				25		36		61
1S-20	G1.1/4"X11				29		46		71
1S-24	G1.1/2"X11				30		50		77
1S-32	G2"X11				35		70		88

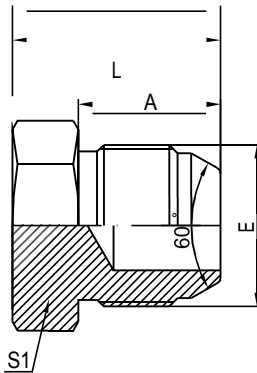

# 4S

日本英管外螺纹60°外锥堵头  
JIS GAS MALE 60° CONE PLUG

代号 PART NO.	螺纹 THREADE				尺寸 DIMENSIONS				
	E				A		S1		L
4S-04	G1/4"X19				15		14		21
4S-06	G3/8"X19				16		17		22
4S-08	G1/2"X14				19		22		26
4S-12	G3/4"X14				23		30		32
4S-16	G1"X11				25		36		36
4S-20	G1.1/4"X11				29		46		42
4S-24	G1.1/2"X11				30		50		47
4S-32	G2"X11				35		70		53

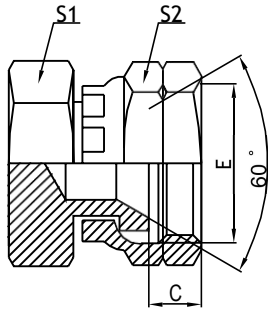

# 9S

日本英管内螺纹60°内锥堵头  
JIS GAS FEMALE 60° SEAT PLUG

代号 PART NO.	螺纹 THREADE				尺寸 DIMENSIONS			
	E				C	S1	S2	
9S-04	G1/4"X19				8	17	19	
9S-06	G3/8"X19				8.5	19	22	
9S-08	G1/2"X14				10.5	22	27	
9S-12	G3/4"X14				14	32	32	
9S-16	G1"X11				14.5	36	41	
9S-20	G1.1/4"X11				16	50	50	
9S-24	G1.1/2"X11				18	55	55	
9S-32	G2"X11				24	70	70	

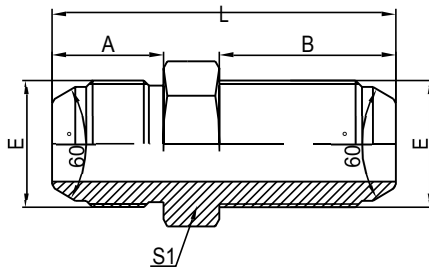

# 6S

日本英管外螺纹60°外锥过板接头  
JIS GAS MALE 60° CONE BULKHEAD

代号 PART NO.	螺纹 THREADE				尺寸 DIMENSIONS				
	E				A	B	S1		L
6S-04	G1/4"X19				15	32	19		53
6S-06	G3/8"X19				16	36	22		59
6S-08	G1/2"X14				19	40	27		68
6S-12	G3/4"X14				23	41	32		74
6S-16	G1"X11				25	45	41		82

备注:如需带锁母订货,则请在代号后加"LN",如6S-04LN;

Remark: In case if you are interested to order the adapter with lock nut, please insert suffix "LN" after our part NO., for example 6S-04LN.



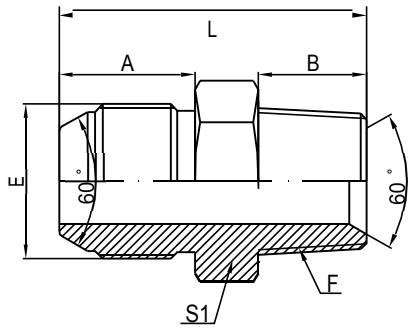

# 1ST

日本英管外螺纹60°外锥/ 英锥管外螺纹  
JIS GAS MALE 60° CONE/BSPT MALE

代号 PART NO.	螺纹 THREADE		尺寸 DIMENSIONS				
	E	F	A	B	S1	L	
1ST-04	G1/4"X19	R1/4"X19	15	14	17	35	
1ST-04-02	G1/4"X19	R1/8"X28	15	10	17	31	
1ST-04-06	G1/4"X19	R3/8"X19	15	14	19	35	
1ST-04-08	G1/4"X19	R1/2"X14	15	19	22	41	
1ST-06	G3/8"X19	R3/8"X19	16	14	19	36	
1ST-06-04	G3/8"X19	R1/4"X19	16	14	19	36	
1ST-06-08	G3/8"X19	R1/2"X14	16	19	22	42	
1ST-08	G1/2"X14	R1/2"X14	19	19	22	45	
1ST-08-04	G1/2"X14	R1/4"X19	19	14	22	40	
1ST-08-06	G1/2"X14	R3/8"X19	19	14	22	40	
1ST-08-12	G1/2"X14	R3/4"X14	19	19.5	27	47.5	
1ST-12	G3/4"X14	R3/4"X14	23	19.5	30	51.5	
1ST-12-08	G3/4"X14	R1/2"X14	23	19	30	51	
1ST-12-16	G3/4"X14	R1"X11	23	24	36	58	
1ST-16	G1"X11	R1"X11	25	24	36	60	
1ST-16-12	G1"X11	R3/4"X14	25	19.5	36	55.5	
1ST-20	G1.1/4"X11	R1.1/4"X11	29	25	46	67	
1ST-24	G1.1/2"X11	R1.1/2"X11	30	25	50	68	
1ST-32	G2"X11	R2"X11	35	29	70	81	

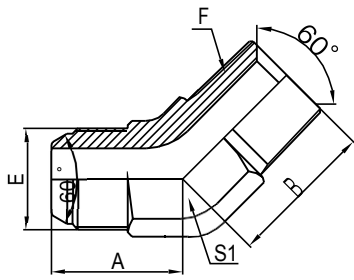

# 1ST4

45° 日本英管外螺纹60°  
 外锥/英锥管外螺纹45°  
 JIS GAS MALE 60° CONE/  
 BSPT MALE

代号 PART NO.	螺纹 THREADE		尺寸 DIMENSIONS				
	E	F	A	B	S1		
1ST4-04	G1/4"X19	R1/4"X19	22	22	14		
1ST4-04-02	G1/4"X19	R1/8"X28	22	22	14		
1ST4-04-06	G1/4"X19	R3/8"X19	22	22	17		
1ST4-04-08	G1/4"X19	R1/2"X14	27	27	22		
1ST4-06	G3/8"X19	R3/8"X19	22	22	17		
1ST4-06-04	G3/8"X19	R1/4"X19	22	22	17		
1ST4-06-08	G3/8"X19	R1/2"X14	27	27	22		
1ST4-08	G1/2"X14	R1/2"X14	27	27	22		
1ST4-08-06	G1/2"X14	R3/8"X19	27	27	22		
1ST4-12	G3/4"X14	R3/4"X14	33	33	27		
1ST4-12-08	G3/4"X14	R1/2"X14	33	33	27		
1ST4-16	G1"X11	R1"X11	37	37	33		
1ST4-16-12	G1"X11	R3/4"X14	37	37	33		
1ST4-20	G1.1/4"X11	R1.1/4"X11	40	40	44		
1ST4-24	G1.1/2"X11	R1.1/2"X11	47	47	53		
1ST4-32	G2"X11	R2"X11	55	55	65		

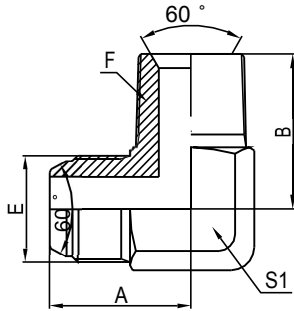

# 1ST9

90° 日本英管外螺纹60°  
 外锥/英锥管外螺纹90°  
 JIS GAS MALE 60° CONE/  
 BSPT MALE

代号 PART NO.	螺纹 THREADE		尺寸 DIMENSIONS				
	E	F	A	B	S1		
1ST9-04	G1/4"X19	R1/4"X19	29	27	14		
1ST9-04-02	G1/4"X19	R1/8"X28	29	27	14		
1ST9-04-06	G1/4"X19	R3/8"X19	29	30	17		
1ST9-06	G3/8"X19	R3/8"X19	30	28	17		
1ST9-06-04	G3/8"X19	R1/4"X19	30	28	17		
1ST9-06-08	G3/8"X19	R1/2"X14	37	37	22		
1ST9-08	G1/2"X14	R1/2"X14	37	37	22		
1ST9-08-06	G1/2"X14	R3/8"X19	37	37	22		
1ST9-08-12	G1/2"X14	R3/4"X14	41	41	27		
1ST9-12	G3/4"X14	R3/4"X14	41	41	27		
1ST9-12-08	G3/4"X14	R1/2"X14	41	41	27		
1ST9-12-16	G3/4"X14	R1"X11	49	49	33		
1ST9-16	G1"X11	R1"X11	49	49	33		
1ST9-20	G1.1/4"X11	R1.1/4"X11	57	57	44		
1ST9-24	G1.1/2"X11	R1.1/2"X11	57	57	48		
1ST9-32	G2"X11	R2"X11	66	63	65		

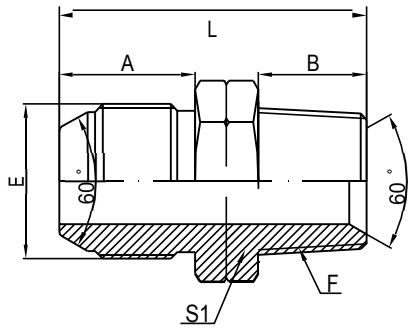

# 1SN

日本英管外螺纹60°外锥/ 布锥管外螺纹  
JIS GAS MALE 60° CONE/NPT MALE

代号 PART NO.	螺纹 THREADE		尺寸 DIMENSIONS				
	E	F	A	B	S1	L	
1SN-04	G1/4"X19	Z1/4"X18	15	14	17	35	
1SN-04-02	G1/4"X19	Z1/8"X27	15	10	17	31	
1SN-04-06	G1/4"X19	Z3/8"X18	15	14	19	35	
1SN-04-08	G1/4"X19	Z1/2"X14	15	19	22	41	
1SN-06	G3/8"X19	Z3/8"X18	16	14	19	36	
1SN-06-04	G3/8"X19	Z1/4"X18	16	14	19	36	
1SN-06-08	G3/8"X19	Z1/2"X14	16	19	22	42	
1ST-08	G1/2"X14	Z1/2"X14	19	19	22	45	
1SN-08-04	G1/2"X14	Z1/4"X18	19	14	22	40	
1SN-08-06	G1/2"X14	Z3/8"X18	19	14	22	40	
1SN-08-12	G1/2"X14	Z3/4"X14	19	19.5	27	47.5	
1SN-12	G3/4"X14	Z3/4"X14	23	19.5	30	51.5	
1SN-12-08	G3/4"X14	Z1/2"X14	23	19	30	51	
1SN-12-16	G3/4"X14	Z1"X11.5	23	24	36	58	
1SN-16	G1"X11	Z1"X11.5	25	24	36	60	
1SN-16-12	G1"X11	Z3/4"X14	25	19.5	36	55.5	
1SN-20	G1.1/4"X11	Z1.1/4"X11.5	29	25	46	67	
1SN-24	G1.1/2"X11	Z1.1/2"X11.5	30	25	50	68	
1SN-32	G2"X11	Z2"X11.5	35	29	70	81	

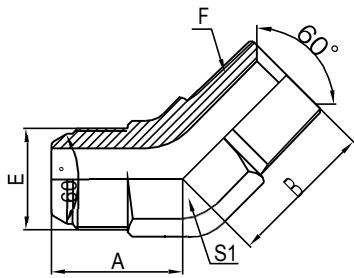

# 1SN4

45° 日本英管外螺纹60°  
 外锥/布锥管外螺纹45°  
 JIS GAS MALE 60°  
 CONE/NPT MALE

代号 PART NO.	螺纹 THREADE		尺寸 DIMENSIONS				
	E	F	A	B	S1		
1SN4-04	G1/4"X19	Z1/4"X19	22	22	14		
1SN4-04-02	G1/4"X19	Z1/8"X27	22	22	14		
1SN4-04-06	G1/4"X19	Z3/8"X18	22	22	17		
1SN4-04-08	G1/4"X19	Z1/2"X14	27	27	22		
1SN4-06	G3/8"X19	Z3/8"X18	22	22	17		
1SN4-06-04	G3/8"X19	Z1/4"X19	22	22	17		
1SN4-06-08	G3/8"X19	Z1/2"X14	27	27	22		
1SN4-08	G1/2"X14	Z1/2"X14	27	27	22		
1SN4-08-06	G1/2"X14	Z3/8"X18	27	27	22		
1SN4-12	G3/4"X14	Z3/4"X14	33	33	27		
1SN4-12-08	G3/4"X14	Z1/2"X14	33	33	27		
1SN4-16	G1"X11	Z1"X11.5	37	37	33		
1SN4-16-12	G1"X11	Z3/4"X14	37	37	33		
1SN4-20	G1.1/4"X11	Z1.1/4"X11.5	40	40	44		
1SN4-24	G1.1/2"X11	Z1.1/2"X11.5	47	47	53		
1SN4-32	G2"X11	Z2"X11.5	55	55	65		

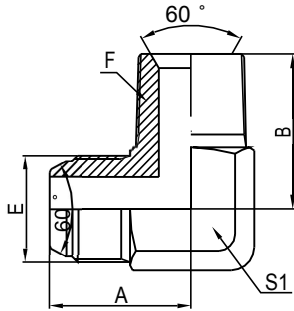

# 1SN9

90° 日本英管外螺纹60°  
 外锥/布锥管外螺纹90°  
 JIS GAS MALE 60°  
 CONE/NPT MALE

代号 PART NO.	螺纹 THREADE		尺寸 DIMENSIONS				
	E	F	A	B	S1		
1SN9-04	G1/4"X19	Z1/4"X18	29	27	14		
1SN9-04-02	G1/4"X19	Z1/8"X27	29	27	14		
1SN9-04-06	G1/4"X19	Z3/8"X18	29	30	17		
1SN9-06	G3/8"X19	Z3/8"X18	30	28	17		
1SN9-06-04	G3/8"X19	Z1/4"X18	30	28	17		
1SN9-06-08	G3/8"X19	Z1/2"X14	37	37	22		
1SN9-08	G1/2"X14	Z1/2"X14	37	37	22		
1SN9-08-06	G1/2"X14	Z3/8"X18	37	37	22		
1SN9-08-12	G1/2"X14	Z3/4"X14	41	41	27		
1SN9-12	G3/4"X14	Z3/4"X14	41	41	27		
1SN9-12-08	G3/4"X14	Z1/2"X14	41	41	27		
1SN9-12-16	G3/4"X14	Z1"X11.5	49	49	33		
1SN9-16	G1"X11	Z1"X11.5	49	49	33		
1SN9-20	G1.1/4"X11	Z1.1/4"X11.5	57	57	44		
1SN9-24	G1.1/2"X11	Z1.1/2"X11.5	57	57	48		
1SN9-32	G2"X11	Z2"X11.5	66	63	65		

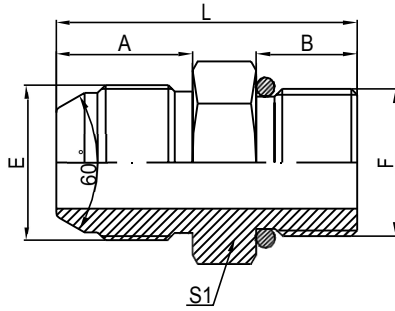

# 1SG

日本英管外螺纹60°外锥/  
英管外螺纹O型圈  
JIS GAS MALE 60° CONE/  
BSP MALE O-RING

代号 PART NO.	螺纹 THREADS		尺寸 DIMENSIONS				
	E	F	A	B	S1	L	
1SG-04	G1/4"X19	G1/4"X19	15	12	19	33	
1SG-06	G3/8"X19	G3/8"X19	16	13.5	22	37	
1SG-08	G1/2"X14	G1/2"X14	19	16	27	44	
1SG-12	G3/4"X14	G3/4"X14	23	18.5	32	51.5	
1SG-16	G1"X11	G1"X11	25	20.5	41	57.5	
1SG-20	G1.1/4"X11	G1.1/4"X11	29	20.5	50	66.5	
1SG-24	G1.1/2"X11	G1.1/2"X11	30	23	55	70	
1SG-32	G2"X11	G2"X11	35	25.5	70	78.5	

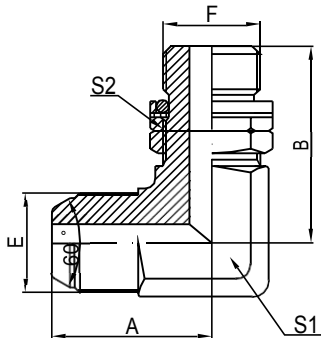

# 1SG9-OG

90°日本英管外螺纹60°外锥/  
英管外螺纹60°O型圈可调向柱端  
90°JIS GAS MALE 60° CONE/  
BSP MALE O-RING ADJUSTABLE STUD

代号 PART NO.	螺纹 THREADS		尺寸 DIMENSIONS			
	E	F	A	B	S1	S2
1SG9-04OG	G1/4"X19	G1/4"X19	29	31.3	14	19
1SG9-06OG	G3/8"X19	G3/8"X19	30	35.8	17	22
1SG9-08OG	G1/2"X14	G1/2"X14	37	43.2	22	27
1SG9-12OG	G3/4"X14	G3/4"X14	41	49.3	27	32
1SG9-16OG	G1"X11	G1"X11	49	53	33	41
1SG9-20OG	G1.1/4"X11	G1.1/4"X11	57	59	44	50
1SG9-24OG	G1.1/2"X11	G1.1/2"X11	57	65	48	55

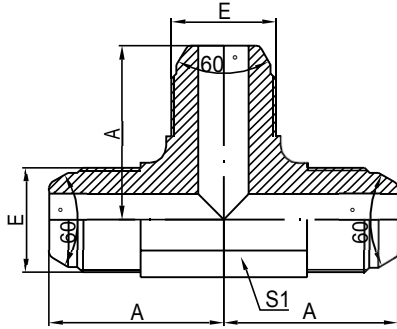

# AS

日本英管外螺纹60°外锥三通  
JIS GAS FEMALE 60° SEAT TEE

代号 PART NO.	螺纹 THREADE		尺寸 DIMENSIONS			
	E	F	A		S1	
AS-04	G1/4"X19	G1/4"X19	27		14	
AS-06	G3/8"X19	G3/8"X19	29		17	
AS-08	G1/2"X14	G1/2"X14	33		22	
AS-12	G3/4"X14	G3/4"X14	40		27	
AS-16	G1"X11	G1"X11	49		33	

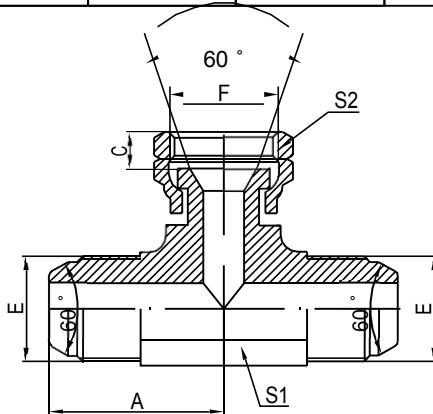

# BS

日本英管外螺纹60°外锥/  
日本英管内螺纹60°内锥分支三通  
JIS GAS MALE 60° CONE/  
JIS GAS FEMALE 60° SEAT BRANCH TEE

代号 PART NO.	螺纹 THREADE		尺寸 DIMENSIONS			
	E	F	A	C	S1	S2
BS-04	G1/4"X19	G1/4"X19	27	8	14	19
BS-06	G3/8"X19	G3/8"X19	29	8.5	17	22
BS-08	G1/2"X14	G1/2"X14	33	10.5	22	27
BS-12	G3/4"X14	G3/4"X14	40	14	27	32
BS-16	G1"X11	G1"X11	49	14.5	33	41



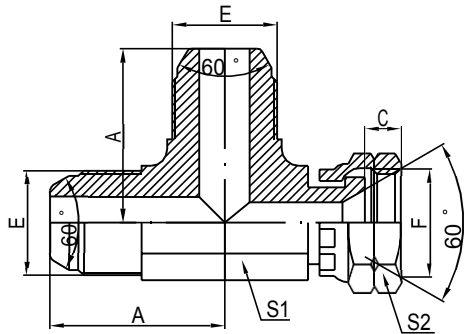

# CS

日本英管外螺纹60°外锥/  
 日本英管内螺纹60°内锥主支三通  
 JIS GAS MALE 60° CONE/  
 JIS GAS FEMALE 60° SEAT RUN TEE

代号 PART NO.	螺纹 THREADE		尺寸 DIMENSIONS				
	E	F	A	C	S1	S2	
CS-04	G1/4"X19	G1/4"X19	27	8	14	19	
CS-06	G3/8"X19	G3/8"X19	29	8.5	17	22	
CS-08	G1/2"X14	G1/2"X14	33	10.5	22	27	
CS-12	G3/4"X14	G3/4"X14	40	14	27	32	
CS-16	G1"X11	G1"X11	49	14.5	33	41	

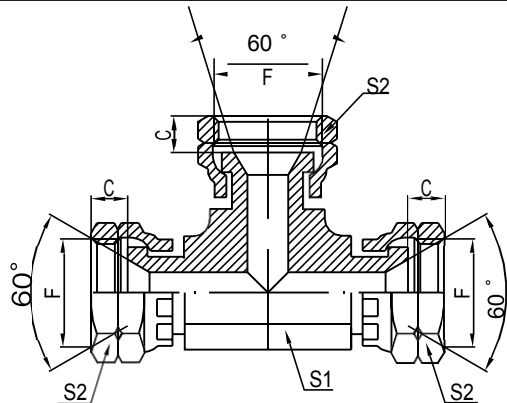

# DS

日本英管内螺纹60°内锥三通  
 JIS GAS FEMALE 60° SEAT TEE

代号 PART NO.	螺纹 THREADE		尺寸 DIMENSIONS			
	E	F	C	S1	S2	
DS-04	G1/4"X19	G1/4"X19	8	14	19	
DS-06	G3/8"X19	G3/8"X19	8.5	17	22	
DS-08	G1/2"X14	G1/2"X14	10.5	22	27	
DS-12	G3/4"X14	G3/4"X14	14	27	32	
DS-16	G1"X11	G1"X11	14.5	33	41	

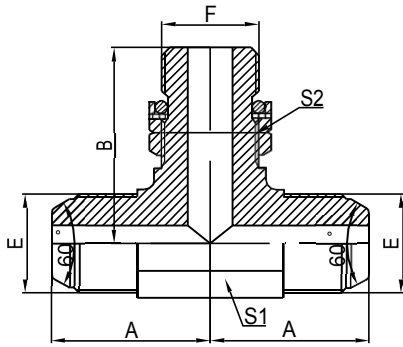

## ASGS-OG

日本英管外螺纹60°外锥/英管外  
 螺纹O型圈可调向柱端分支三通 JIS  
 GAS MALE 60° CONE/BSP MALE  
 O-RING ADJUSTABLE STUD BRANCH TEE

代号 PART NO.	螺纹 THREADS		尺寸 DIMENSIONS				
	E	F	A	B	S1	S2	
ASGS-04OG	G1/4"X19	G1/4"X19	27	31.3	14	19	
ASGS-06OG	G3/8"X19	G3/8"X19	29	35.8	17	22	
ASGS-08OG	G1/2"X14	G1/2"X14	33	43.2	22	27	
ASGS-12OG	G3/4"X14	G3/4"X14	40	49.3	27	32	
ASGS-16OG	G1"X11	G1"X11	49	54.5	33	41	
ASGS-20OG	G1.1/4"X11	G1.1/4"X11	57	59	44	50	

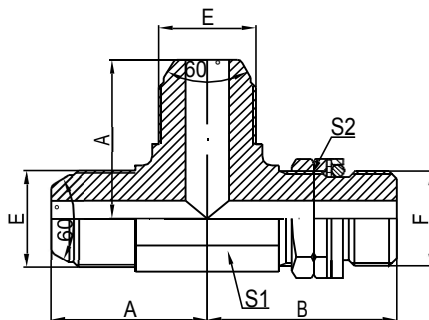

## ASSG-OG

日本英管外螺纹60°外锥/英管外  
 螺纹O型圈可调向柱端主支三通 JIS  
 GAS MALE 60° CONE/BSP MALE  
 O-RING ADJUSTABLE STUD END RUN TEE

代号 PART NO.	螺纹 THREADS		尺寸 DIMENSIONS				
	E	F	A	B	S1	S2	
ASSG-04OG	G1/4"X19	G1/4"X19	27	31	14	19	
ASSG-06OG	G3/8"X19	G3/8"X19	29	35.5	17	22	
ASSG-08OG	G1/2"X14	G1/2"X14	33	43.5	22	27	
ASSG-12OG	G3/4"X14	G3/4"X14	40	49.5	27	32	
ASSG-16OG	G1"X11	G1"X11	49	54.5	33	41	
ASSG-20OG	G1.1/4"X11	G1.1/4"X11	57	59	44	50	

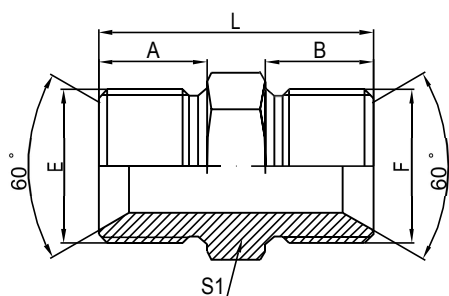

# 1B

英管外螺纹60°内锥或  
六角端面组合垫密封  
BSP MALE DOUBLE FOR  
60° SEAT BONDED SEAL

代号 PART NO.	螺纹 THREADS		尺寸 DIMENSIONS				
	E	F	A	B	S1	L	
1B-02	G1/8"X28	G1/8"X28	10	10	14	26	
1B-02-04	G1/8"X28	G1/4"X19	10	12	19	28	
1B-02-06	G1/8"X28	G3/8"X19	10	13.5	22	31.5	
1B-02-08	G1/8"X28	G1/2"X14	10	16	27	34	
1B-04	G1/4"X19	G1/4"X19	12	12	19	30	
1B-04-06	G1/4"X19	G3/8"X19	12	13.5	22	33	
1B-04-08	G1/4"X19	G1/2"X14	12	16	27	36	
1B-04-10	G1/4"X19	G5/8"X14	12	17.5	30	38.5	
1B-06	G3/8"X19	G3/8"X19	13.5	13.5	22	35	
1B-06-08	G3/8"X19	G1/2"X14	13.5	16	27	37.5	
1B-06-10	G3/8"X19	G5/8"X14	13.5	17.5	30	40	
1B-06-12	G3/8"X19	G3/4"X14	13.5	18.5	32	42	
1B-08	G1/2"X14	G1/2"X14	16	16	27	40	
1B-08-10	G1/2"X14	G5/8"X14	16	17.5	30	42.5	
1B-08-12	G1/2"X14	G3/4"X14	16	18.5	32	44	
1B-10	G5/8"X14	G5/8"X14	17.5	17.5	30	44	
1B-10-12	G5/8"X14	G3/4"X14	17.5	18.5	32	46	
1B-10-16	G5/8"X14	G1"X11	17.5	20.5	41	50	
1B-12	G3/4"X14	G3/4"X14	18.5	18.5	32	47	
1B-12-16	G3/4"X14	G1"X11	18.5	20.5	41	49	
1B-12-20	G3/4"X14	G1.1/4"X11	18.5	20.5	50	56	
1B-16	G1"X11	G1"X11	20.5	20.5	41	53	
1B-16-20	G1"X11	G1.1/4"X11	20.5	20.5	50	57	
1B-16-24	G1"X11	G1.1/2"X11	20.5	23	55	60	
1B-20	G1.1/4"X11	G1.1/4"X11	20.5	20.5	50	58	
1B-20-24	G1.1/4"X11	G1.1/2"X11	20.5	23	55	61	
1B-24	G1.1/2"X11	G1.1/2"X11	23	23	55	63	
1B-24-32	G1.1/2"X11	G2"X11	23	25.5	70	66	
1B-32	G2"X11	G2"X11	25.5	25.5	70	69	

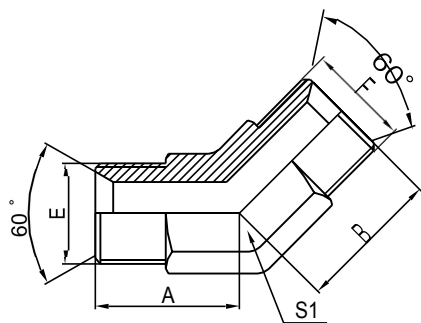

# 1B4

45° 英管外螺纹60° 内锥  
45° BSP MALE 60° SEAT

代号 PART NO.	螺纹 THREADE		尺寸 DIMENSIONS				
	E	F	A	B	S1		
1B4-02-04	G1/8"X28	G1/4"X19	22	22	14		
1B4-04	G1/4"X19	G1/4"X19	22	22	14		
1B4-04-06	G1/4"X19	G3/8"X19	22	22	17		
1B4-06	G3/8"X19	G3/8"X19	22	22	17		
1B4-06-08	G3/8"X19	G1/2"X14	27	27	22		
1B4-08	G1/2"X14	G1/2"X14	27	27	22		
1B4-08-12	G1/2"X14	G3/4"X14	33	33	27		
1B4-10	G5/8"X14	G5/8"X14	27	27	22		
1B4-10-12	G5/8"X14	G3/4"X14	33	33	27		
1B4-12	G3/4"X14	G3/4"X14	33	33	27		
1B4-12-16	G3/4"X14	G1"X11	37	37	33		
1B4-16	G1"X11	G1"X11	37	37	33		
1B4-16-20	G1"X11	G1.1/4"X11	40	40	44		
1B4-20	G1.1/4"X11	G1.1/4"X11	40	40	44		
1B4-20-24	G1.1/4"X11	G1.1/2"X11	47	47	53		
1B4-24	G1.1/2"X11	G1.1/2"X11	47	47	53		
1B4-32	G2"X11	G2"X11	55	55	65		

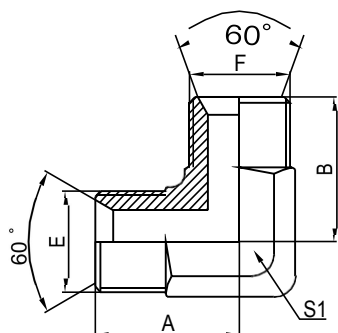

# 1B9

90° 英管外螺纹60° 内锥  
90° BSP MALE 60° SEAT

代号 PART NO.	螺纹 THREADE		尺寸 DIMENSIONS				
	E	F	A	B	S1		
1B9-02-04	G1/8"X28	G1/4"X19	27	29	14		
1B9-04	G1/4"X19	G1/4"X19	29	27	14		
1B9-04-06	G1/4"X19	G3/8"X19	28	30	17		
1B9-06	G3/8"X19	G3/8"X19	30	28	17		
1B9-06-08	G3/8"X19	G1/2"X14	37	37	22		
1B9-08	G1/2"X14	G1/2"X14	37	37	22		
1B9-08-12	G1/2"X14	G3/4"X14	41	41	27		
1B9-10	G5/8"X14	G5/8"X14	37	37	22		
1B9-10-12	G5/8"X14	G3/4"X14	41	41	27		
1B9-12	G3/4"X14	G3/4"X14	41	41	27		
1B9-12-16	G3/4"X14	G1"X11	49	49	33		
1B9-16	G1"X11	G1"X11	49	49	33		
1B9-16-20	G1"X11	G1.1/4"X11	57	57	44		
1B9-20	G1.1/4"X11	G1.1/4"X11	57	57	44		
1B9-20-24	G1.1/4"X11	G1.1/2"X11	57	57	48		
1B9-24	G1.1/2"X11	G1.1/2"X11	57	57	48		
1B9-32	G2"X11	G2"X11	66	63	65		

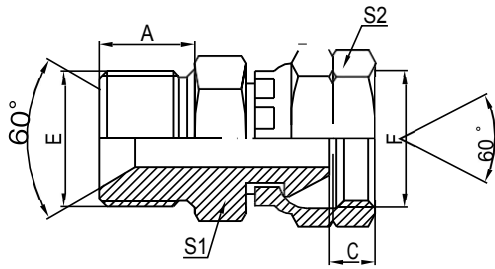

# 2B

英管外螺纹60°内锥或六角端面组合  
 垫密封/英管内螺纹60°外锥  
 BSP MALE DOUBLE FOR 60° SEAT  
 BONDED SEAL /BSP FEMALE 60° CONE

代号 PART NO.	螺纹 THREADE		尺寸 DIMENSIONS				
	E	F	A	C	S1	S2	
2B-02	G1/8"X28	G1/8"X28	10	5.5	14	14	
2B-02-04	G1/8"X28	G1/4"X19	10	5.5	14	19	
2B-04	G1/4"X19	G1/4"X19	12	5.5	19	19	
2B-04-06	G1/4"X19	G3/8"X19	12	6.5	19	22	
2B-04-08	G1/4"X19	G1/2"X14	12	8	19	27	
2B-06	G3/8"X19	G3/8"X19	13.5	6.5	22	22	
2B-06-08	G3/8"X19	G1/2"X14	13.5	8	22	27	
2B-06-10	G3/8"X19	G5/8"X14	13.5	10.5	22	30	
2B-08	G1/2"X14	G1/2"X14	16	8	27	27	
2B-08-06	G1/2"X14	G3/8"X19	16	6.5	27	27	
2B-10	G5/8"X14	G5/8"X14	17.5	10.5	30	30	
2B-10-08	G5/8"X14	G1/2"X14	17.5	8	30	27	
2B-10-12	G5/8"X14	G3/4"X14	17.5	11.5	30	32	
2B-12	G3/4"X14	G3/4"X14	18.5	11.5	32	32	
2B-12-10	G3/4"X14	G5/8"X14	18.5	10.5	32	30	
2B-12-16	G3/4"X14	G1"X11	18.5	11.5	32	41	
2B-16	G1"X11	G1"X11	20.5	11.5	41	41	
2B-16-12	G1"X11	G3/4"X14	20.5	11.5	41	32	
2B-16-20	G1"X11	G1.1/4"X11	20.5	12	41	50	
2B-20	G1.1/4"X11	G1.1/4"X11	20.5	12	50	50	
2B-20-16	G1.1/4"X11	G1"X11	20.5	11.5	50	41	
2B-20-24	G1.1/4"X11	G1.1/2"X11	20.5	13	50	55	
2B-24	G1.1/2"X11	G1.1/2"X11	23	13	55	55	
2B-32	G2"X11	G2"X11	25.5	16	70	70	

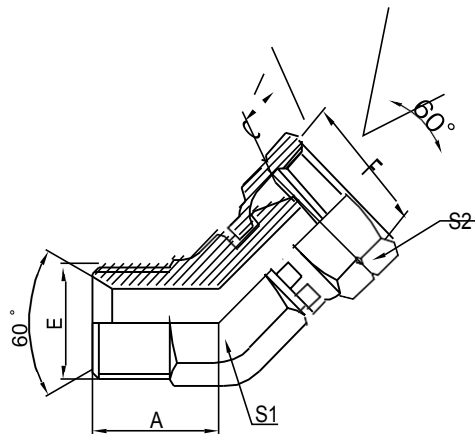

# 2B4

45° 英管外螺纹60° 内锥/  
 英管内螺纹60° 外锥45°  
 BSP MALE 60° SEAT/ BSP  
 FEMALE 60° CONE

代号 PART NO.	螺纹 THREADE		尺寸 DIMENSIONS				
	E	F	A	C	S1	S2	
2B4-04	G1/4"X19	G1/4"X19	22	5.5	14	19	
2B4-04-06	G1/4"X19	G3/8"X19	22	6.5	17	22	
2B4-06	G3/8"X19	G3/8"X19	22	6.5	17	22	
2B4-06-04	G3/8"X19	G1/4"X19	22	5.5	17	19	
2B4-08	G1/2"X14	G1/2"X14	27	8	22	27	
2B4-08-06	G1/2"X14	G3/8"X19	27	6.5	22	22	
2B4-10	G5/8"X14	G5/8"X14	27	10.5	22	30	
2B4-10-08	G5/8"X14	G1/2"X14	27	8	22	27	
2B4-12	G3/4"X14	G3/4"X14	33	11.5	27	32	
2B4-16	G1"X11	G1"X11	37	11.5	33	41	
2B4-20	G1.1/4"X11	G1.1/4"X11	40	12	44	50	
2B4-24	G1.1/2"X11	G1.1/2"X11	47	13	53	55	
2B4-32	G2"X11	G2"X11	55	16	65	70	

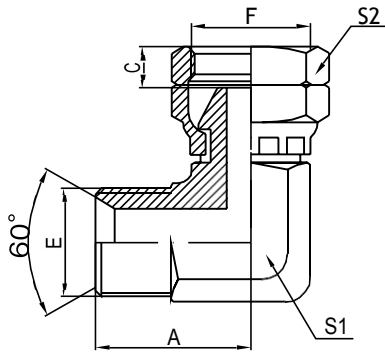

# 2B9

90° 英管外螺纹60° 内锥/  
 英管内螺纹60° 外锥90°  
 BSP MALE 60° SEAT/ BSP  
 FEMALE 60° CONE

代号 PART NO.	螺纹 THREADE		尺寸 DIMENSIONS				
	E	F	A	C	S1	S2	
2B9-02	G1/8"X28	G1/8"X28	23	5.5	11	14	
2B9-04	G1/4"X19	G1/4"X19	29	5.5	14	19	
2B9-04-06	G1/4"X19	G3/8"X19	30	6.5	17	22	
2B9-06	G3/8"X19	G3/8"X19	30	6.5	17	22	
2B9-06-04	G3/8"X19	G1/4"X19	30	5.5	17	19	
2B9-08	G1/2"X14	G1/2"X14	37	8	22	27	
2B9-08-06	G1/2"X14	G3/8"X19	37	6.5	22	22	
2B9-10	G5/8"X14	G5/8"X14	37	10.5	22	30	
2B9-10-08	G5/8"X14	G1/2"X14	37	8	22	27	
2B9-12	G3/4"X14	G3/4"X14	41	11.5	27	32	
2B9-16	G1"X11	G1"X11	49	11.5	33	41	
2B9-20	G1.1/4"X11	G1.1/4"X11	57	12	44	50	
2B9-24	G1.1/2"X11	G1.1/2"X11	57	13	48	55	
2B9-32	G2"X11	G2"X11	66	16	65	70	



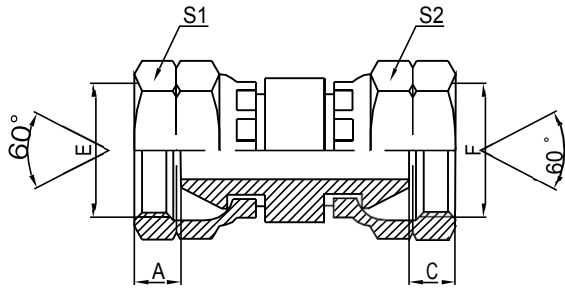

# 3B

英管内螺纹60°外锥  
BSP FEMALE 60° CONE

代号 PART NO.	螺纹 THREADE		尺寸 DIMENSIONS				
	E	F	A	C	S1	S2	
3B-02	G1/8"X28	G1/8"X28	5.5	5.5	14	14	
3B-02-04	G1/8"X28	G1/4"X19	5.5	5.5	14	19	
3B-04	G1/4"X19	G1/4"X19	5.5	5.5	19	19	
3B-04-06	G1/4"X19	G3/8"X19	5.5	6.5	19	22	
3B-04-08	G1/4"X19	G1/2"X14	5.5	8	19	27	
3B-06	G3/8"X19	G3/8"X19	6.5	6.5	22	22	
3B-06-08	G3/8"X19	G1/2"X14	6.5	8	22	27	
3B-08	G1/2"X14	G1/2"X14	8	8	27	27	
3B-08-10	G1/2"X14	G5/8"X14	8	10.5	27	30	
3B-08-12	G1/2"X14	G3/4"X14	8	11.5	27	32	
3B-10	G5/8"X14	G5/8"X14	10.5	10.5	30	30	
3B-10-12	G5/8"X14	G3/4"X14	10.5	11.5	30	32	
3B-12	G3/4"X14	G3/4"X14	11.5	11.5	32	32	
3B-12-16	G3/4"X14	G1"X11	11.5	11.5	32	41	
3B-16	G1"X11	G1"X11	11.5	11.5	41	41	
3B-16-20	G1"X11	G1.1/4"X11	11.5	12	41	50	
3B-20	G1.1/4"X11	G1.1/4"X11	12	12	50	50	
3B-24	G1.1/2"X11	G1.1/2"X11	13	13	55	55	
3B-32	G2"X11	G2"X11	16	16	70	70	

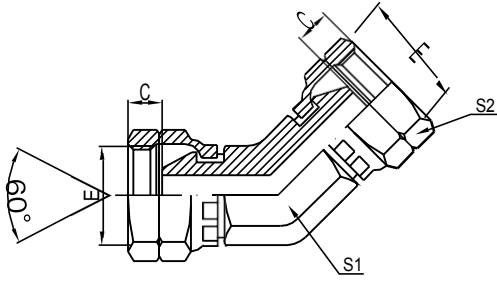

# 3B4

45° 英管内螺纹60° 外锥  
45° BSP FEMALE 60° CONE

代号 PART NO.	螺纹 THREADE				尺寸 DIMENSIONS			
	E				C	S1	S2	
3B4-02	G1/8"X28				5.5	11	14	
3B4-04	G1/4"X19				5.5	11	19	
3B4-06	G3/8"X19				6.5	17	22	
3B4-08	G1/2"X14				8	19	27	
3B4-10	G5/8"X14				10.5	22	30	
3B4-12	G3/4"X14				11.5	27	32	
3B4-16	G1"X11				11.5	33	41	
3B4-20	G1.1/4"X11				12	44	50	
3B4-24	G1.1/2"X11				13	50	55	
3B4-32	G2"X11				16	65	70	

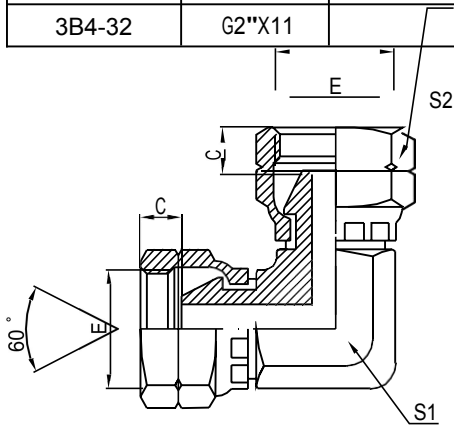

# 3B9

90° 英管内螺纹60° 外锥  
90° BSP FEMALE 60° CONE

代号 PART NO.	螺纹 THREADE				尺寸 DIMENSIONS			
	E				C	S1	S2	
3B9-02	G1/8"X28				5.5	11	14	
3B9-04	G1/4"X19				5.5	11	19	
3B9-06	G3/8"X19				6.5	17	22	
3B9-08	G1/2"X14				8	19	27	
3B9-10	G5/8"X14				10.5	22	30	
3B9-12	G3/4"X14				11.5	27	32	
3B9-16	G1"X11				11.5	33	41	
3B9-20	G1.1/4"X11				12	44	50	
3B9-24	G1.1/2"X11				13	50	55	
3B9-32	G2"X11				16	65	70	

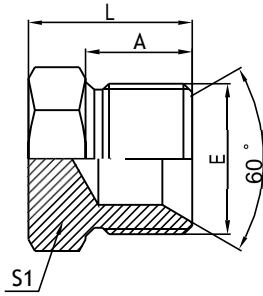

# 4B

英管外螺纹60°内锥或六角  
 端面用组合垫密封堵头  
 BSP MALE DOUBLE FOR 60°  
 SEAT OR BONDED SEAL PLUG

代号 PART NO.	螺纹 THREADE			尺寸 DIMENSIONS			
	E			A	S1	L	
4B-02	G1/8"X28			10	14	16	
4B-04	G1/4"X19			12	19	18	
4B-06	G3/8"X19			13.5	22	21	
4B-08	G1/2"X14			16	27	24	
4B-10	G5/8"X14			17.5	30	27	
4B-12	G3/4"X14			18.5	32	28	
4B-16	G1"X11			20.5	41	32	
4B-20	G1.1/4"X11			20.5	50	37	
4B-24	G1.1/2"X11			23	55	40	
4B-32	G2"X11			25.5	70	43	

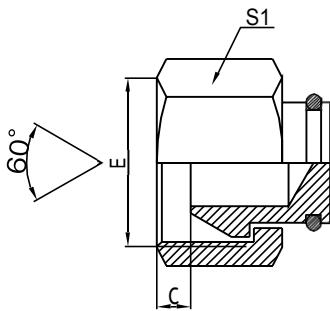

# 9B

英管内螺纹60°外锥堵头  
 BSP FEMALE 60° CONE PLUG

代号 PART NO.	螺纹 THREADE			尺寸 DIMENSIONS			
	E			C	S1		
9B-04	G1/4"X19			5.5	17		
9B-06	G3/8"X19			6	22		
9B-08	G1/2"X14			7	27		
9B-10	G5/8"X14			8.5	27		
9B-12	G3/4"X14			9	32		
9B-16	G1"X11			11	38		
9B-20	G1.1/4"X11			11	50		
9B-24	G1.1/2"X11			12	55		
9B-32	G2"X11			15	70		

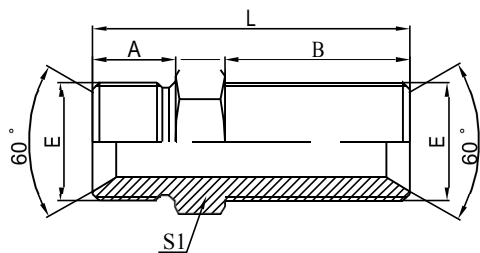

# 6B

英管外螺纹60°内锥过板接头  
BSP MALE 60° SEAT BULKHEAD

代号 PART NO.	螺纹 THREADE			尺寸 DIMENSIONS			
	E			A	B	S1	L
6B-02	G1/8"X28			10	33	14	49
6B-04	G1/4"X19			12	35	19	53
6B-06	G3/8"X19			13.5	35	22	56
6B-08	G1/2"X14			16	39	27	63
6B-10	G5/8"X14			17.5	40	30	67.5
6B-12	G3/4"X14			18.5	42	32	70
6B-16	G1"X11			20.5	50	41	83
6B-20	G1.1/4"X11			20.5	52	50	89.5
6B-24	G1.1/2"X11			23	55	55	95
6B-32	G2"X11			25.5	55	70	98.5

备注:如需带锁母订货,则请在代号后加"LN",如6B-12LN;  
Remark:In case if you are interested to order the adapter with lock nut,please insert suffix"LN"after our part NO.,for example 6B-12LN.

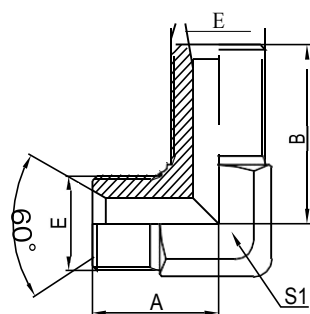

# 6B9

90°英管外螺纹60°内锥过板接头  
90° BSP MALE 60° SEAT BULKHEAD

代号 PART NO.	螺纹 THREADE			尺寸 DIMENSIONS			
	E			A	B	S1	
6B9-04	G1/4"X19			29	51	14	
6B9-06	G3/8"X19			30	53.5	17	
6B9-08	G1/2"X14			37	58.5	22	
6B9-12	G3/4"X14			41	64	27	
6B9-16	G1"X11			49	71	33	

备注:如需带锁母订货,则请在代号后加"LN",如6B9-12LN;  
Remark:In case if you are interested to order the adapter with lock nut,please insert suffix"LN"after our part NO.,for example 6B9-12LN.

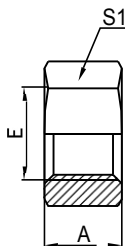

# 8B

英管螺纹锁母  
BSP LOCK NUT

代号 PART NO.	螺纹 THREADE			尺寸 DIMENSIONS				
	E			A		S1		
8B-02	G1/8"X28			5.5		14		
8B-04	G1/4"X19			6.5		19		
8B-06	G3/8"X19			7		22		
8B-08	G1/2"X14			9		27		
8B-10	G5/8"X14			9		30		
8B-12	G3/4"X14			10.5		32		
8B-16	G1"X11			10.5		41		
8B-20	G1.1/4"X11			10.5		50		
8B-24	G1.1/2"X11			10.5		55		
8B-32	G2"X11			10.5		70		

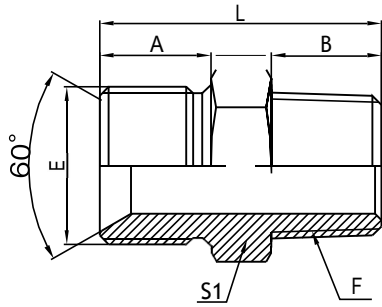

# 1BT

英管外螺纹60°内锥或六角端面  
组合垫密封/英锥管外螺纹  
BSP MALE DOUBLE FOR 60° SEAT  
BONDED SEAL / BSPT MALE

代号 PART NO.	螺纹 THREADS		尺寸 DIMENSIONS				
	E	F	A	B	S1	L	
1BT-02	G1/8"X28	R1/8"X28	10	10	14	26	
1BT-02-04	G1/8"X28	R1/4"X19	10	14	14	30	
1BT-04	G1/4"X19	R1/4"X19	12	14	19	32	
1BT-04-02	G1/4"X19	R1/8"X28	12	10	19	28	
1BT-04-06	G1/4"X19	R3/8"X19	12	14	19	32	
1BT-06	G3/8"X19	R3/8"X19	13.5	14	22	35	
1BT-06-04	G3/8"X19	R1/4"X19	13.5	14	22	35	
1BT-06-08	G3/8"X19	R1/2"X14	13.5	19	22	41	
1BT-08	G1/2"X14	R1/2"X14	16	19	27	45	
1BT-08-06	G1/2"X14	R3/8"X19	16	14	27	40	
1BT-08-12	G1/2"X14	R3/4"X14	16	19.5	27	45	
1BT-10-08	G5/8"X14	R1/2"X14	17.5	19	30	45	
1BT-10-12	G5/8"X14	R3/4"X14	17.5	19.5	30	47	
1BT-12	G3/4"X14	R3/4"X14	18.5	19.5	32	48	
1BT-12-08	G3/4"X14	R1/2"X14	18.5	19	32	47	
1BT-12-16	G3/4"X14	R1"X11	18.5	24	36	53	
1BT-16	G1"X11	R1"X11	20.5	24	41	58	
1BT-16-12	G1"X11	R3/4"X14	20.5	19.5	41	53	
1BT-16-20	G1"X11	R1.1/4"X11	20.5	25	46	59	
1BT-20	G1.1/4"X11	R1.1/4"X11	20.5	25	50	62	
1BT-20-16	G1.1/4"X11	R1"X11	20.5	24	50	61	
1BT-20-24	G1.1/4"X11	R1.1/2"X11	20.5	25	50	62	
1BT-24	G1.1/2"X11	R1.1/2"X11	23	25	55	65	
1BT-24-16	G1.1/2"X11	R1"X11	23	24	55	61	
1BT-24-20	G1.1/2"X11	R1.1/4"X11	23	25	55	65	
1BT-24-32	G1.1/2"X11	R2"X11	23	29	65	69	
1BT-32	G2"X11	R2"X11	25.5	29	70	72	
1BT-32-24	G2"X11	R1.1/2"X11	25.5	25	70	68	

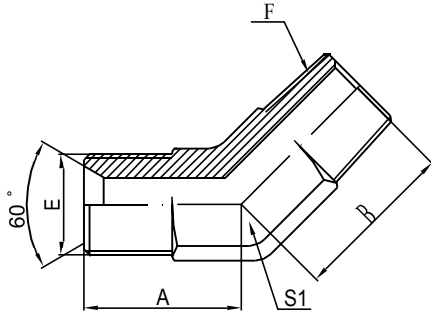

# 1BT4

45° 英管外螺纹60° 内锥 / 英锥管外螺纹  
45° BSP MALE 60° SEAT / BSPT MALE

代号 PART NO.	螺纹 THREADE		尺寸 DIMENSIONS				
	E	F	A	B	S1		
1BT4-02	G1/8"X28	R1/8"X28	17	17	11		
1BT4-04	G1/4"X19	R1/4"X19	22	22	14		
1BT4-04-06	G1/4"X19	R3/8"X19	22	22	17		
1BT4-06	G3/8"X19	R3/8"X19	22	22	17		
1BT4-06-04	G3/8"X19	R1/4"X19	22	22	17		
1BT4-06-08	G3/8"X19	R1/2"X14	27	27	22		
1BT4-06-12	G3/8"X19	R3/4"X14	33	33	27		
1BT4-08	G1/2"X14	R1/2"X14	27	27	22		
1BT4-08-06	G1/2"X14	R3/8"X19	27	27	22		
1BT4-08-12	G1/2"X14	R3/4"X14	33	33	27		
1BT4-10-08	G5/8"X14	R1/2"X14	27	27	22		
1BT4-10-12	G5/8"X14	R3/4"X14	33	33	27		
1BT4-12	G3/4"X14	R3/4"X14	33	33	27		
1BT4-12-08	G3/4"X14	R1/2"X14	33	33	27		
1BT4-12-16	G3/4"X14	R1"X11	37	37	33		
1BT4-16	G1"X11	R1"X11	37	37	33		
1BT4-16-12	G1"X11	R3/4"X14	37	37	33		
1BT4-16-20	G1"X11	R1.1/4"X11	40	40	44		
1BT4-20	G1.1/4"X11	R1.1/4"X11	40	40	44		
1BT4-20-16	G1.1/4"X11	R1"X11	40	40	44		
1BT4-20-24	G1.1/4"X11	R1.1/2"X11	47	47	52		
1BT4-24	G1.1/2"X11	R1.1/2"X11	47	47	52		
1BT4-24-20	G1.1/2"X11	R1.1/4"X11	47	47	52		
1BT4-24-32	G1.1/2"X11	R2"X11	55	55	65		
1BT4-32	G2"X11	R2"X11	55	55	65		
1BT4-32-24	G2"X11	R1.1/2"X11	55	55	65		

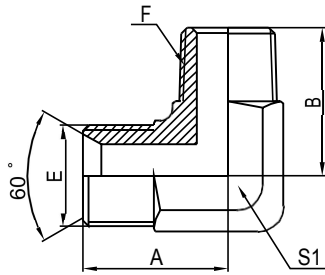

# 1BT9

90° 英管外螺纹60° 内锥/ 英锥管外螺纹  
90° BSP MALE 60° SEAT /BSPT MALE

代号 PART NO.	螺纹 THREADS		尺寸 DIMENSIONS				
	E	F	A	B	S1		
1BT9-02	G1/8"X28	R1/8"X28	25	25	11		
1BT9-02-04	G1/8"X28	R1/4"X19	27	29	14		
1BT9-04	G1/4"X19	R1/4"X19	29	27	14		
1BT9-04-02	G1/4"X19	R1/8"X28	29	27	14		
1BT9-04-06	G1/4"X19	R3/8"X19	29	30	17		
1BT9-06	G3/8"X19	R3/8"X19	30	29	17		
1BT9-06-04	G3/8"X19	R1/4"X19	30	29	17		
1BT9-06-08	G3/8"X19	R1/2"X14	37	37	22		
1BT9-08	G1/2"X14	R1/2"X14	37	37	22		
1BT9-08-06	G1/2"X14	R3/8"X19	37	37	22		
1BT9-08-12	G1/2"X14	R3/4"X14	41	41	27		
1BT9-10-08	G5/8"X14	R1/2"X14	41	41	27		
1BT9-10-12	G5/8"X14	R3/4"X14	41	41	27		
1BT9-12	G3/4"X14	R3/4"X14	41	41	27		
1BT9-12-08	G3/4"X14	R1/2"X14	41	41	27		
1BT9-12-16	G3/4"X14	R1"X11	49	49	33		
1BT9-16	G1"X11	R1"X11	49	49	33		
1BT9-16-12	G1"X11	R3/4"X14	49	49	33		
1BT9-16-20	G1"X11	R1.1/4"X11	57	57	44		
1BT9-20	G1.1/4"X11	R1.1/4"X11	57	57	44		
1BT9-20-16	G1.1/4"X11	R1"X11	57	57	44		
1BT9-20-24	G1.1/4"X11	R1.1/2"X11	57	57	48		
1BT9-24	G1.1/2"X11	R1.1/2"X11	57	57	48		
1BT9-24-20	G1.1/2"X11	R1.1/4"X11	57	57	48		
1BT9-24-32	G1.1/2"X11	R2"X11	66	66	65		
1BT9-32	G2"X11	R2"X11	66	66	65		
1BT9-32-24	G2"X11	R1.1/2"X11	66	66	65		



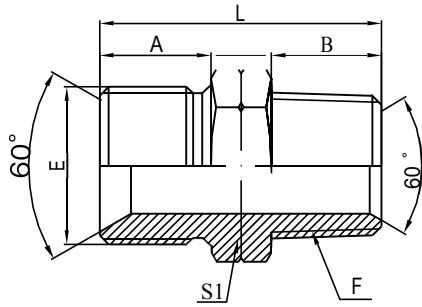

# 1BN

英管外螺纹60°内锥六角或端面  
组合垫密封/布锥管外螺纹  
BSP MALE DOUBLE FOR 60° SEAT  
BONDED SEAL/NPT MALE

代号 PART NO.	螺纹 THREADS		尺寸 DIMENSIONS				
	E	F	A	B	S1	L	
1BN-02	G1/8"X28	Z1/8"X27	10	10	14	26	
1BN-02-04	G1/8"X28	Z1/4"X18	10	14	14	30	
1BN-04	G1/4"X19	Z1/4"X18	12	14	19	32	
1BN-04-02	G1/4"X19	Z1/8"X27	12	10	19	28	
1BN-04-06	G1/4"X19	Z3/8"X18	12	14	19	32	
1BN-06	G3/8"X19	Z3/8"X18	13.5	14	22	35	
1BN-06-04	G3/8"X19	Z1/4"X18	13.5	14	22	35	
1BN-06-08	G3/8"X19	Z1/2"X14	13.5	19	22	41	
1BN-08	G1/2"X14	Z1/2"X14	16	19	27	45	
1BN-08-06	G1/2"X14	Z3/8"X18	16	14	27	40	
1BN-08-12	G1/2"X14	Z3/4"X14	16	19.5	27	45	
1BN-10-08	G5/8"X14	Z1/2"X14	17.5	19	30	45	
1BN-10-12	G5/8"X14	Z3/4"X14	17.5	19.5	30	47	
1BN-12	G3/4"X14	Z3/4"X14	18.5	19.5	32	48	
1BN-12-08	G3/4"X14	Z1/2"X14	18.5	19	32	47	
1BN-12-16	G3/4"X14	Z1"X11.5	18.5	24	36	53	
1BN-16	G1"X11	Z1"X11.5	20.5	24	41	58	
1BN-16-12	G1"X11	Z3/4"X14	20.5	19.5	41	53	
1BN-16-20	G1"X11	Z1.1/4"X11.5	20.5	25	46	59	
1BN-20	G1.1/4"X11	Z1.1/4"X11.5	20.5	25	50	62	
1BN-20-16	G1.1/4"X11	Z1"X11.5	20.5	24	50	61	
1BN-20-24	G1.1/4"X11	Z1.1/2"X11.5	20.5	25	50	62	
1BN-24	G1.1/2"X11	Z1.1/2"X11.5	23	25	55	65	
1BN-24-20	G1.1/2"X11	Z1.1/4"X11.5	23	25	55	65	
1BN-24-32	G1.1/2"X11	Z2"X11.5	23	29	65	69	
1BN-32	G2"X11	Z2"X11.5	25.5	29	70	72	
1BN-32-24	G2"X11	Z1.1/2"X11.5	25.5	25	70	68	

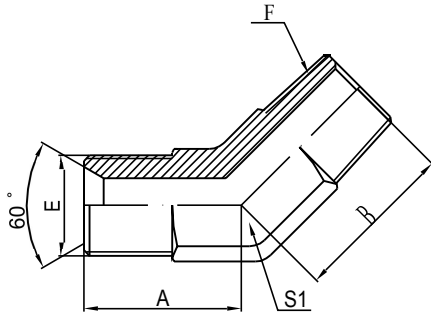

# 1BN4

45° 英管外螺纹 60° 内锥 / 布锥管外螺纹  
 45° BSP MALE 60° SEAT / NPT MALE

代号 PART NO.	螺纹 THREADE		尺寸 DIMENSIONS				
	E	F	A	B	S1		
1BN4-04	G1/4"X19	Z1/4"X18	22	22	14		
1BN4-04-02	G1/4"X19	Z1/8"X27	22	22	14		
1BN4-06	G3/8"X19	Z3/8"X18	22	22	17		
1BN4-06-04	G3/8"X19	Z1/4"X18	22	22	17		
1BN4-06-08	G3/8"X19	Z1/2"X14	27	27	22		
1BN4-06-12	G3/8"X19	Z3/4"X14	33	33	27		
1BN4-08	G1/2"X14	Z1/2"X14	27	27	22		
1BN4-08-06	G1/2"X14	Z3/8"X18	27	27	22		
1BN4-12	G3/4"X14	Z3/4"X14	33	33	27		
1BN4-12-08	G3/4"X14	Z1/2"X14	33	33	27		
1BN4-12-16	G3/4"X14	Z1"X11.5	37	37	33		
1BN4-16	G1"X11	Z1"X11.5	37	37	33		
1BN4-16-12	G1"X11	Z3/4"X14	37	37	33		
1BN4-20	G1.1/4"X11	Z1.1/4"X11.5	40	40	44		
1BN4-24	G1.1/2"X11	Z1.1/2"X11.5	47	47	52		
1BN4-32	G2"X11	Z2"X11.5	55	55	65		

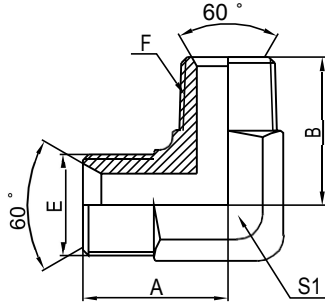

# 1BN9

90° 英管外螺纹 60° 内锥 / 布锥管外螺纹  
 90° BSP MALE 60° SEAT / NPT MALE

代号 PART NO.	螺纹 THREADE		尺寸 DIMENSIONS				
	E	F	A	B	S1		
1BN9-04	G1/4"X19	Z1/4"X18	29	27	14		
1BN9-04-02	G1/4"X19	Z1/8"X27	29	27	14		
1BN9-06	G3/8"X19	Z3/8"X18	30	29	17		
1BN9-06-04	G3/8"X19	Z1/4"X18	30	29	17		
1BN9-06-08	G3/8"X19	Z1/2"X14	37	37	22		
1BN9-06-12	G3/8"X19	Z3/4"X14	41	41	27		
1BN9-08	G1/2"X14	Z1/2"X14	37	37	22		
1BN9-08-06	G1/2"X14	Z3/8"X18	37	37	22		
1BN9-12	G3/4"X14	Z3/4"X14	41	41	27		
1BN9-12-08	G3/4"X14	Z1/2"X14	41	41	27		
1BN9-12-16	G3/4"X14	Z1"X11.5	49	49	33		
1BN9-16	G1"X11	Z1"X11.5	49	49	33		
1BN9-16-12	G1"X11	Z3/4"X14	49	49	33		
1BN9-20	G1.1/4"X11	Z1.1 / 4"X11.5	57	57	44		
1BN9-24	G1.1/2"X11	Z1.1 / 2"X11.5	57	57	48		
1BN9-32	G2"X11	Z2"X11.5	66	66	65		

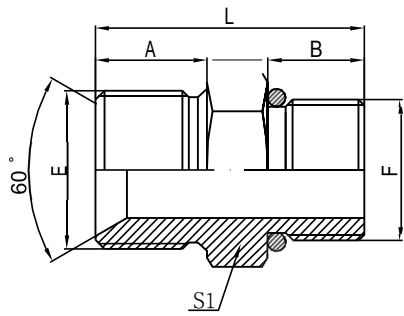

# 1BG

英管外螺纹60°内锥或六角端面  
 组合垫密封/英锥管外螺纹O型圈  
 BSP MALE DOUBLE FOR 60° SEAT  
 BONDED SEAL/BSPT MALE O-RING

代号 PART NO.	螺纹 THREADE		尺寸 DIMENSIONS				
	E	F	A	B	S1	L	
1BG-02	G1/8"X28	G1/8"X28	10	9	14	25	
1BG-04	G1/4"X19	G1/4"X19	12	12	19	30	
1BG-04-06	G1/4"X19	G3/8"X19	12	13.5	19	31.5	
1BG-06	G3/8"X19	G3/8"X19	13.5	13.5	22	35	
1BG-06-04	G3/8"X19	G1/4"X19	13.5	12	22	33.5	
1BG-06-08	G3/8"X19	G1/2"X14	13.5	16	27	39.5	
1BG-08	G1/2"X14	G1/2"X14	16	16	27	42	
1BG-08-06	G1/2"X14	G3/8"X19	16	13.5	27	39.5	
1BG-08-12	G1/2"X14	G3/4"X14	16	18.5	27	44.5	
1BG-10-08	G5/8"X14	G1/2"X14	17.5	16	30	43.5	
1BG-12	G3/4"X14	G3/4"X14	18.5	18.5	32	47	
1BG-12-08	G3/4"X14	G1/2"X14	18.5	16	32	44.5	
1BG-16-08	G1"X11	G1/2"X14	20.5	16	41	48.5	
1BG-16	G1"X11	G1"X11	20.5	20.5	41	53	
1BG-16-12	G1"X11	G3/4"X14	20.5	18.5	41	51	
1BG-20	G1.1/4"X11	G1.1/4"X11	20.5	20.5	50	58	
1BG-24	G1.1/2"X11	G1.1/2"X11	23	23	55	63	

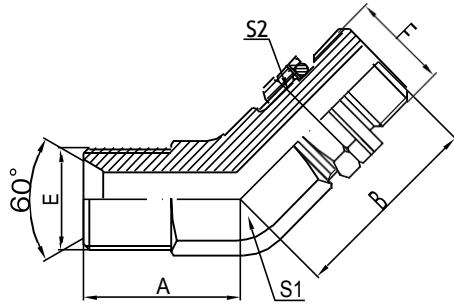

# 1BG4-OG

45° 英管外螺纹60° 内锥/  
 英管外螺纹O型圈可调向柱端  
 45° BSP MALE 60° SEAT/BSP  
 MALE O-RING ADJUSTABLE STUD END

代号 PART NO.	螺纹 THREADE		尺寸 DIMENSIONS				
	E	F	A	B	S1	S2	
1BG4-04OG	G1/4"X19	G1/4"X19	22	28	14	19	
1BG4-04-06OG	G1/4"X19	G3/8"X19	22	30	17	22	
1BG4-04-08OG	G1/4"X19	G1/2"X14	27	36	22	27	
1BG4-06OG	G3/8"X19	G3/8"X19	22	30	17	22	
1BG4-06-08OG	G3/8"X19	G1/2"X14	27	36	22	27	
1BG4-08OG	G1/2"X14	G1/2"X14	27	36	22	27	
1BG4-12OG	G3/4"X14	G3/4"X14	33	42	27	32	
1BG4-12-16OG	G3/4"X14	G1"X11	37	44	33	41	
1BG4-16OG	G1"X11	G1"X11	37	44	33	41	
1BG4-20OG	G1.1/4"X11	G1.1/4"X11	40	47.5	44	50	
1BG4-24OG	G1.1/2"X11	G1.1/2"X11	47	51.5	52	55	

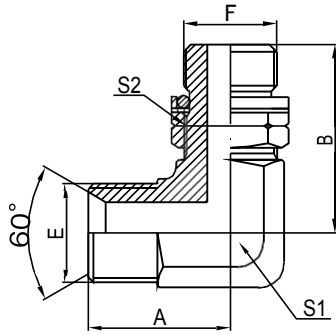

# 1BG9-OG

90° 英管外螺纹60° 内锥/  
 英管外螺纹O型圈可调向柱端  
 90° BSP MALE 60° SEAT/BSP  
 MALE O-RING ADJUSTABLE STUD END

代号 PART NO.	螺纹 THREADE		尺寸 DIMENSIONS				
	E	F	A	B	S1	S2	
1BG9-04OG	G1/4"X19	G1/4"X19	29	31.5	14	19	
1BG9-04-06OG	G1/4"X19	G3/8"X19	30	36.8	17	22	
1BG9-06OG	G3/8"X19	G3/8"X19	30	36.8	17	22	
1BG9-06-08OG	G3/8"X19	G1/2"X14	37	43.2	22	27	
1BG9-08OG	G1/2"X14	G1/2"X14	37	43.2	22	27	
1BG9-08-12OG	G1/2"X14	G3/4"X14	41	49.3	27	32	
1BG9-12OG	G3/4"X14	G3/4"X14	41	49.3	27	32	
1BG9-12-16OG	G3/4"X14	G1"X11	49	53	33	41	
1BG9-16OG	G1"X11	G1"X11	49	53	33	41	
1BG9-20-16OG	G1.1/4"X11	G1"X11	57	58	44	41	
1BG9-20OG	G1.1/4"X11	G1.1/4"X11	57	58	44	50	
1BG9-24OG	G1.1/2"X11	G1.1/2"X11	57	63	48	55	

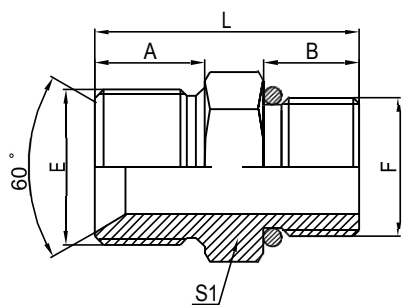

# 1BH

英管外螺纹60°内锥或六角端面  
 组合垫密封/公制外螺纹轻系列  
 BSP MALE DOUBLE FOR 60° SEAT  
 BONDED SEAL/METRIC MALE L-SERIES

代号 PART NO.	螺纹 THREADE		尺寸 DIMENSIONS				
	E	F	A	B	S1	L	
1BH-02-10	G1/8"X28	M10x1	10	11	14	27	
1BH-02-12	G1/8"X28	M12x1.5	10	11	14	27	
1BH-04-12	G1/4"X19	M12x1.5	12	11	19	29	
1BH-04-14	G1/4"X19	M14x1.5	12	11	19	29	
1BH-04-16	G1/4"X19	M16x1.5	12	11	19	29	
1BH-06-14	G3/8"X19	M14x1.5	13.5	11	22	32.5	
1BH-06-16	G3/8"X19	M16x1.5	13.5	11	22	32.5	
1BH-06-18	G3/8"X19	M18x1.5	13.5	11	22	32.5	
1BH-08-18	G1/2"X14	M18x1.5	16	11	27	37	
1BH-08-22	G1/2"X14	M22x1.5	16	12	27	38	
1BH-10-22	G5/8"X14	M22x1.5	17.5	12	30	39.5	
1BH-12-16	G3/4"X14	M16x1.5	18.5	11	32	39.5	
1BH-12-22	G3/4"X14	M22x1.5	18.5	12	32	40.5	
1BH-12-27	G3/4"X14	M27x1.5	18.5	13	32	41.5	
1BH-16-27	G1"X11	M27x1.5	20.5	13	41	45.5	

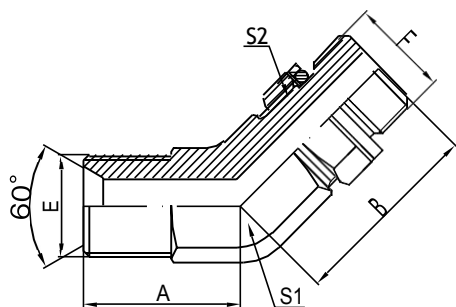

# 1BH4-OG

45° 英管外螺纹60° 内锥/  
公制外螺纹轻系列 45°  
BSP MALE 60° SEAT/  
METRIC MALE O-RING

代号 PART NO.	螺纹 THREADE		尺寸 DIMENSIONS				
	E	F	A	B	S1	S2	
1BH4-02-10OG	G1/8"X28	M10x1	20	23.5	11	14	
1BH4-02-12OG	G1/8"X28	M12x1.5	20	27.5	11	17	
1BH4-04-12OG	G1/4"X19	M12x1.5	22	28.3	14	17	
1BH4-04-14OG	G1/4"X19	M14x1.5	22	28.3	14	19	
1BH4-04-16OG	G1/4"X19	M16x1.5	22	29.3	17	22	
1BH4-06-14OG	G3/8"X19	M14x1.5	22	28.8	17	19	
1BH4-06-16OG	G3/8"X19	M16x1.5	22	29.3	17	22	
1BH4-06-18OG	G3/8"X19	M18x1.5	25	31	19	24	
1BH4-08-18OG	G1/2"X14	M18x1.5	27	33.3	22	24	
1BH4-08-22OG	G1/2"X14	M22x1.5	33	33.3	27	27	
1BH4-10-22OG	G5/8"X14	M22x1.5	33	33.3	27	27	
1BH4-12-22OG	G3/4"X14	M22x1.5	33	34.5	27	27	
1BH4-12-27OG	G3/4"X14	M27x1.5	33	39.5	27	32	
1BH4-16-27OG	G1"X11	M27x1.5	37	40.5	33	32	



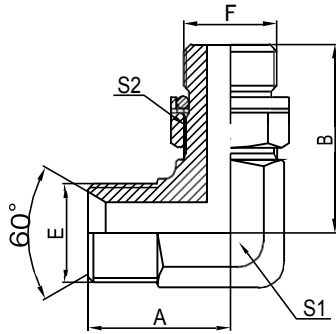

# 1BH9-OG

90° 英管外螺纹60° 内锥/  
公制外螺纹轻系列 90°  
BSP MALE 60° SEAT/  
METRIC MALE O-RING

代号 PART NO.	螺纹 THREADE		尺寸 DIMENSIONS				
	E	F	A	B	S1	S2	
1BH9-02-10OG	G1/8"X28	M10x1	25	26.5	11	14	
1BH9-02-12OG	G1/8"X28	M12x1.5	25	30.5	11	17	
1BH9-04-12OG	G1/4"X19	M12x1.5	29	32	14	17	
1BH9-04-14OG	G1/4"X19	M14x1.5	29	32.5	14	19	
1BH9-04-16OG	G1/4"X19	M16x1.5	30	34.8	17	22	
1BH9-06-14OG	G3/8"X19	M14x1.5	30	34	17	19	
1BH9-06-16OG	G3/8"X19	M16x1.5	30	34.8	17	22	
1BH9-06-18OG	G3/8"X19	M18x1.5	33	37	19	24	
1BH9-08-18OG	G1/2"X14	M18x1.5	37	39.5	22	24	
1BH9-08-22OG	G1/2"X14	M22x1.5	40	40.2	27	27	
1BH9-10-22OG	G5/8"X14	M22x1.5	40	40.2	27	27	
1BH9-12-22OG	G3/4"X14	M22x1.5	40	43.5	27	27	
1BH9-12-27OG	G3/4"X14	M27x1.5	40	48.5	27	32	
1BH9-16-27OG	G1"X11	M27x1.5	49	52	33	32	

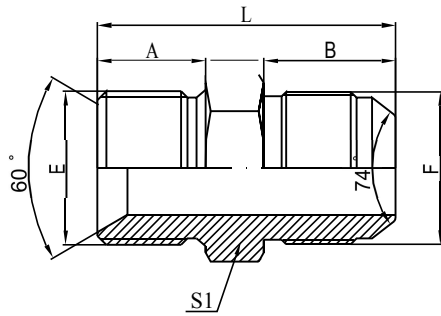

# 1BJ

英管外螺纹60°内锥或六角端面组  
合垫密封/美制JIC外螺纹74°外锥  
BSP MALE DOUBLE FOR 60° SEAT  
BONDED SEAL/JIC MALE 74° CONE

代号 PART NO.	螺纹 THREADS		尺寸 DIMENSIONS				
	E	F	A	B	S1	L	
1BJ-02-04	G1/8"X28	U7/16"X20	10	14	14	30	
1BJ-02-05	G1/8"X28	U1/2"X20	10	14	14	30	
1BJ-02-06	G1/8"X28	U9/16"X18	10	14	14	30	
1BJ-04	G1/4"X19	U7/16"X20	12	14	19	32	
1BJ-04-05	G1/4"X19	U1/2"X20	12	14	19	32	
1BJ-04-06	G1/4"X19	U9/16"X18	12	14	19	32	
1BJ-04-08	G1/4"X19	U3/4"X16	12	16.7	19	37	
1BJ-04-10	G1/4"X19	U7/8"X14	12	19.5	22	39.5	
1BJ-06	G3/8"X19	U9/16"X18	13.5	14	22	35	
1BJ-06-04	G3/8"X19	U7/16"X20	13.5	14	22	35	
1BJ-06-05	G3/8"X19	U1/2"X20	13.5	14	22	35	
1BJ-06-08	G3/8"X19	U3/4"X16	13.5	16.7	22	38	
1BJ-06-10	G3/8"X19	U7/8"X14	13.5	19.5	22	41	
1BJ-06-12	G3/8"X19	U1.1/16"X12	13.5	22	30	44.5	
1BJ-08	G1/2"X14	U3/4"X16	16	16.7	27	42	
1BJ-08-04	G1/2"X14	U7/16"X20	16	14	27	40	
1BJ-08-05	G1/2"X14	U1/2"X20	16	14	27	40	
1BJ-08-06	G1/2"X14	U9/16"X18	16	14	27	40	
1BJ-08-10	G1/2"X14	U7/8"X14	16	19.5	27	45.5	
1BJ-08-12	G1/2"X14	U1.1/16"X12	16	22	30	47	
1BJ-08-16	G1/2"X14	U1.5/16"X12	16	23	36	50	
1BJ-10	G5/8"X14	U7/8"X14	17.5	19.5	30	46	
1BJ-10-08	G5/8"X14	U3/4"X16	17.5	16.7	30	43	
1BJ-10-12	G5/8"X14	U1.1/16"X12	17.5	22	30	48.5	
1BJ-10-16	G5/8"X14	U1.5/16"X12	17.5	23	36	51.5	
1BJ-12	G3/4"X14	U1.1/16"X12	18.5	22	32	50	
1BJ-12-06	G3/4"X14	U9/16"X18	18.5	14	32	42	
1BJ-12-08	G3/4"X14	U3/4"X16	18.5	16.7	32	46	
1BJ-12-10	G3/4"X14	U7/8"X14	18.5	19.5	32	49	

接上页

代号 PART NO.	螺纹 THREADS		尺寸 DIMENSIONS				
	E	F	A	B	S1	L	
1BJ-12-16	G3/4"X14	U1.5/16"X12	18.5	23	36	52	
1BJ-12-20	G3/4"X14	U1.5/8"X12	18.5	24.5	46	56	
1BJ-16	G1"X11	U1.5/16"X12	20.5	23	41	56	
1BJ-16-08	G1"X11	U3/4"X16	20.5	16.7	41	49	
1BJ-16-10	G1"X11	U7/8"X14	20.5	19.5	41	52	
1BJ-16-12	G1"X11	U1.1/16"X12	20.5	22	41	54	
1BJ-16-20	G1"X11	U1.5/8"X12	20.5	24.5	46	59.5	
1BJ-20	G1.1/4"X11	U1.5/8"X12	20.5	24.5	50	62	
1BJ-20-12	G1.1/4"X11	U1.1/16"X12	20.5	22	50	59	
1BJ-20-16	G1.1/4"X11	U1.5/16"X12	20.5	23	50	60	
1BJ-20-24	G1.1/4"X11	U1.7/8"X12	20.5	27.5	50	65	
1BJ-24-16	G1.1/2"X11	U1.5/16"X12	23	23	55	63	
1BJ-24-20	G1.1/2"X11	U1.5/8"X12	23	24.5	55	64	
1BJ-24	G1.1/2"X11	U1.7/8"X12	23	27.5	55	67	
1BJ-24-32	G1.1/2"X11	U2.1/2"X12	23	34	65	74	
1BJ-32	G2"X11	U2.1/2"X12	25.5	34	70	77	
1BJ-32-24	G2"X11	U1.7/8"X12	25.5	27.5	70	71	

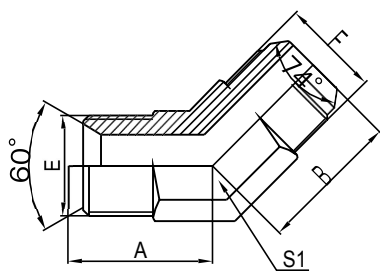

# 1BJ4

45° 英管外螺纹60° 内锥/  
 美制JIC外螺纹74° 外锥  
 45° BSP MALE 60° SEAT/  
 JIC MALE 74° CONE

代号 PART NO.	螺纹 THREADE		尺寸 DIMENSIONS				
	E	F	A	B	S1		
1BJ4-04	G1/4"X19	U7/16"X20	22	22	14		
1BJ4-04-05	G1/4"X19	U1/2"X20	22	22	14		
1BJ4-04-06	G1/4"X19	U9/16"X18	22	22	14		
1BJ4-06	G3/8"X19	U9/16"X18	22	22	17		
1BJ4-06-08	G3/8"X19	U3/4"X16	25	25	19		
1BJ4-08	G1/2"X14	U3/4"X16	27	27	22		
1BJ4-08-10	G1/2"X14	U7/8"X14	27	27	22		
1BJ4-10	G5/8"X14	U7/8"X14	33	33	27		
1BJ4-12	G3/4"X14	U1.1/16"X12	33	33	27		
1BJ4-16	G1"X11	U1.5/16"X12	37	37	33		
1BJ4-16-20	G1"X11	U1.5/8"X12	40	40	44		
1BJ4-20	G1.1/4"X11	U1.5/8"X12	40	40	44		
1BJ4-24	G1.1/2"X11	U1.7/8"X12	47	47	53		
1BJ4-32	G2"X11	U2.1/2"X12	55	55	65		

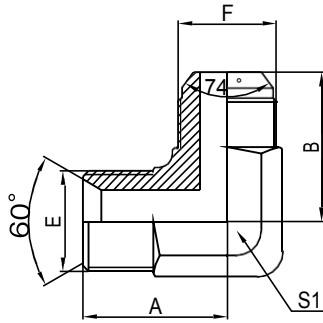

# 1BJ9

90° 英管外螺纹60° 内锥/  
美制JIC外螺纹74° 外锥  
90° BSP MALE 60° SEAT/  
JIC MALE 74° CONE

代号 PART NO.	螺纹 THREADE		尺寸 DIMENSIONS				
	E	F	A	B	S1		
1BJ9-04	G1/4"X19	U7/16"X20	27	29	14		
1BJ9-04-05	G1/4"X19	U1/2"X20	27	29	14		
1BJ9-04-06	G1/4"X19	U9/16"X18	27	29	14		
1BJ9-06	G3/8"X19	U9/16"X18	29	30	17		
1BJ9-06-08	G3/8"X19	U3/4"X16	33	33	19		
1BJ9-08	G1/2"X14	U3/4"X16	37	37	22		
1BJ9-08-10	G1/2"X14	U7/8"X14	37	37	22		
1BJ9-10	G5/8"X14	U7/8"X14	40	40	27		
1BJ9-12	G3/4"X14	U1.1/16"X12	40	40	27		
1BJ9-16	G1"X11	U1.5/16"X12	49	49	33		
1BJ9-16-20	G1"X11	U1.5/8"X12	57	57	44		
1BJ9-20	G1.1/4"X11	U1.5/8"X12	57	57	44		
1BJ9-24	G1.1/2"X11	U1.7/8"X12	57	57	48		
1BJ9-32	G2"X11	U2.1/2"X12	66	66	65		

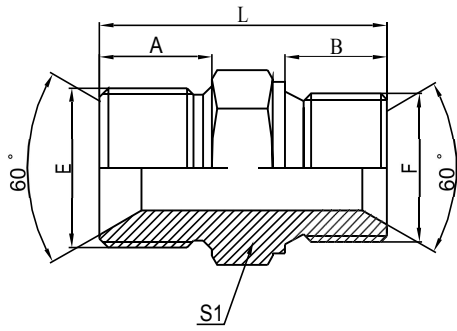

# 1BM

英管外螺纹60°内锥或六角端面组合垫密封/  
 公制外螺纹60°内锥或六角端面组合垫密封  
 BSP MALE 60° SEAT DOUBLE 60° SEAT  
 BONDED SEAL/METRIC MALE  
 DOUBLE 60° SEAT BONDED SEAL

代号 PART NO.	螺纹 THREADE		尺寸 DIMENSIONS				
	E	F	A	B	S1	L	
1BM-02-12	G1/8"X28	M12x1.5	10	10	17	28	
1BM-04-12	G1/4"X19	M12x1.5	12	10	19	30	
1BM-04-14	G1/4"X19	M14x1.5	12	11	19	31	
1BM-04-16	G1/4"X19	M16x1.5	12	12	22	34	
1BM-04-18	G1/4"X19	M18x1.5	12	12	24	34	
1BM-06-12	G3/8"X19	M12x1.5	13.5	10	22	32.5	
1BM-06-14	G3/8"X19	M14x1.5	13.5	11	22	33.5	
1BM-06-16	G3/8"X19	M16x1.5	13.5	12	22	34.5	
1BM-06-18	G3/8"X19	M18x1.5	13.5	12	24	34.5	
1BM-06-22	G3/8"X19	M22x1.5	13.5	14	27	39.5	
1BM-08-14	G1/2"X14	M14x1.5	16	11	27	39	
1BM-08-16	G1/2"X14	M16x1.5	16	12	27	40	
1BM-08-18	G1/2"X14	M18x1.5	16	12	27	40	
1BM-08-22	G1/2"X14	M22x1.5	16	14	27	42	
1BM-10-22	G5/8"X14	M22x1.5	17.5	14	30	43.5	
1BM-12-18	G3/4"X14	M18x1.5	18.5	12	32	42.5	
1BM-12-22	G3/4"X14	M22x1.5	18.5	14	32	44.5	
1BM-16-14	G1"X11	M14x1.5	20.5	11	41	46	
1BM-16-22	G1"X11	M22x1.5	20.5	14	41	49	

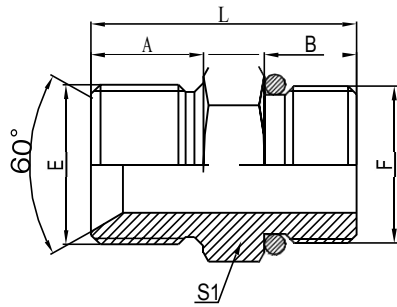

# 1BO

英管外螺纹60°内锥或六角端面组合垫密封  
 /美制SAE外螺纹带O型圈轻系列  
 BSP MALE 60° SEAT BONDED SEAL  
 /SAE O-RING BOSS L-SERIES

代号 PART NO.	螺纹 THREADS		尺寸 DIMENSIONS				
	E	F	A	B	S1	L	
1BO-04	G1/4"X19	U7/16"X20	12	10	19	28	
1BO-04-05	G1/4"X19	U1/2"X20	12	10	19	28	
1BO-04-06	G1/4"X19	U9/16"X18	12	12	19	30	
1BO-04-08	G1/4"X19	U3/4"X16	12	12	22	32	
1BO-06	G3/8"X19	U9/16"X18	13.5	12	22	33.5	
1BO-06-04	G3/8"X19	U7/16"X20	13.5	10	22	31.5	
1BO-06-08	G3/8"X19	U3/4"X16	13.5	12	24	33.5	
1BO-06-10	G3/8"X19	U7/8"X14	13.5	13.5	27	37	
1BO-08	G1/2"X14	U3/4"X16	16	12	27	38	
1BO-08-06	G1/2"X14	U9/16"X18	16	12	27	38	
1BO-08-10	G1/2"X14	U7/8"X14	16	13.5	27	39.5	
1BO-08-12	G1/2"X14	U1.1/16"X12	16	16	32	42	
1BO-10	G5/8"X14	U7/8"X14	17.5	13.5	30	41	
1BO-10-08	G5/8"X14	U7/8"X14	17.5	12	30	39.5	
1BO-10-12	G5/8"X14	U1.1/16"X12	17.5	16	32	43.5	
1BO-12	G3/4"X14	U1.1/16"X12	18.5	16	32	44.5	
1BO-12-08	G3/4"X14	U3/4"X16	18.5	12	32	40.5	
1BO-12-10	G3/4"X14	U7/8"X14	18.5	13.5	32	42	
1BO-12-16	G3/4"X14	U1.5/16"X12	18.5	17	41	47.5	
1BO-16	G1"X11	U1.5/16"X12	20.5	17	41	49.5	
1BO-16-10	G1"X11	U7/8"X14	20.5	13.5	41	46	
1BO-16-12	G1"X11	U1.1/16"X12	20.5	16	41	48.5	
1BO-16-20	G1"X11	U1.5/8"X12	20.5	18	50	55.5	
1BO-20	G1.1/4"X11	U1.5/8"X12	20.5	18	50	55.5	
1BO-20-16	G1.1/4"X11	U1.5/16"X12	20.5	17	50	54.5	
1BO-24	G1.1/2"X11	U1.7/8"X12	23	18.5	55	58.5	

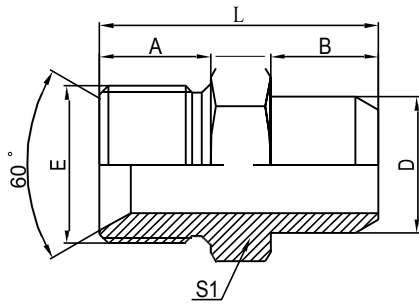

# 1BW

英管外螺纹60°内锥或六角  
端面组合垫密封/焊接管BSP  
MALE 60° SEAT BONDED SEAL  
/ BUTT-WELD TUBE

代号 PART NO.	螺纹 THREADE		管子外径 TUBE O.D.		尺寸 DIMENSIONS				
	E		D		A	B	S1	L	
1BW-04-10	G1/4"X19		10		12	7	19	25	
1BW-06-14	G3/8"X19		14		13.5	8	22	29.5	
1BW-08-18	G1/2"X14		18		16	10	27	36	
1BW-12-22	G3/4"X14		22		18.5	10	32	38.5	
1BW-12-28	G3/4"X14		28		18.5	12	32	40.5	
1BW-16-28	G1"X11		28		20.5	12	41	44.5	
1BW-16-30	G1"X11		30		20.5	12	41	44.5	
1BW-20-34	G1.1/4"X11		34		20.5	14	50	51.5	
1BW-20-36	G1.1/4"X11		36		20.5	14	50	51.5	
1BW-20-42	G1.1/4"X11		42		20.5	16	50	53.5	
1BW-24-36	G1.1/2"X11		36		23	14	55	54	
1BW-24-42	G1.1/4"X11		42		23	16	55	56	
1BW-24-50	G1.1/2"X11		50		23	16	55	56	

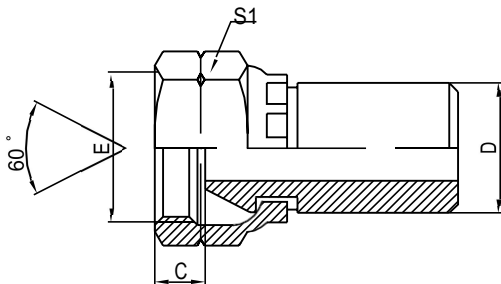

# 2WB

焊接管/ 英管内螺纹60°外锥  
BUTT-WELD TUBE/BSP FEMALE 60° CONE

代号 PART NO.	螺纹 THREADE		管子外径 TUBE O.D.		尺寸 DIMENSIONS				
	E		D		C		S1		
2WB-10-04	G1/4"X19		10		5.5		19		
2WB-14-06	G3/8"X19		14		6.5		22		
2WB-18-08	G1/2"X14		18		8		27		
2WB-22-08	G1/2"X14		22		8		27		
2WB-22-12	G3/4"X14		22		11.5		32		
2WB-28-16	G1"X11		28		11.5		41		
2WB-34-20	G1.1/4"X11		34		12		50		
2WB-42-20	G1.1/4"X11		42		12		50		
2WB-50-24	G1.1/2"X11		50		13		55		



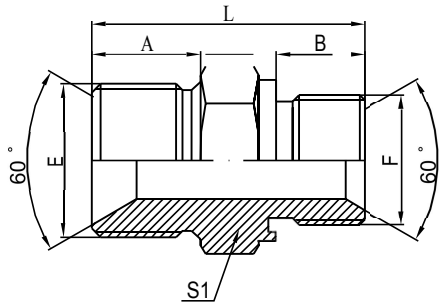

# 1B-WD

英管外螺纹60°内锥或六角端面组合垫密封  
 /英管外螺纹胶垫密封  
 BSP MALE 60° SEAT BONDED SEAL  
 /BSP MALE CAPTIVE SEAL

代号 PART NO.	螺纹 THREADE		尺寸 DIMENSIONS				
	E	F	A	B	S1	L	
1B-04WD	G1/4"X19	G1/4"X19	12	12	19	32	
1B-04-06WD	G1/4"X19	G3/8"X19	12	13.5	22	36	
1B-04-08WD	G1/4"X19	G1/2"X14	12	16	27	41	
1B-06WD	G3/8"X19	G3/8"X19	13.5	13.5	22	35.5	
1B-06-08WD	G3/8"X19	G1/2"X14	13.5	16	27	42.5	
1B-08WD	G1/2"X14	G1/2"X14	16	16	27	45	
1B-08-12WD	G1/2"X14	G3/4"X14	16	18.5	32	48.5	
1B-12WD	G3/4"X14	G3/4"X14	18.5	18.5	32	49	
1B-12-16WD	G3/4"X14	G1"X11	18.5	20.5	41	55	
1B-16WD	G1"X11	G1"X11	20.5	20.5	41	57	
1B-16-20WD	G1"X11	G1.1/4"X11	20.5	20.5	50	59	
1B-20WD	G1.1/4"X11	G1.1/4"X11	20.5	20.5	50	59	

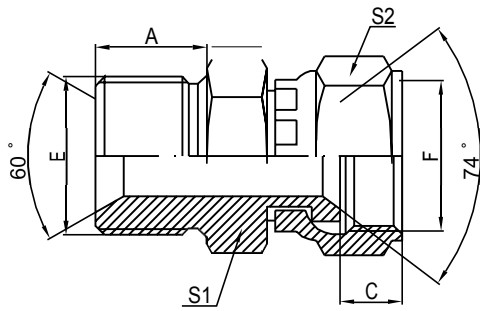

# 2BJ

英管外螺纹60°内锥或六角端面组合垫密封/美制JIC内螺纹74°内锥  
 BSP MALE DOUBLE FOR 60° SEAT  
 BONDED SEAL/JIC FEMALE 74° SEAT

代号 PART NO.	螺纹 THREADS		尺寸 DIMENSIONS				
	E	F	A	C	S1	S2	
2BJ-02-04	G1/8"X28	U7/16"X20	10	8.5	14	17	
2BJ-02-06	G1/8"X28	U9/16"X18	10	10	14	19	
2BJ-04	G1/4"X19	U7/16"X20	12	8.5	19	17	
2BJ-04-05	G1/4"X19	U1/2"X20	12	9.5	19	19	
2BJ-04-06	G1/4"X19	U9/16"X18	12	10	19	19	
2BJ-04-08	G1/4"X19	U3/4"X16	12	11	19	24	
2BJ-06	G3/8"X19	U9/16"X18	13.5	10	22	19	
2BJ-06-08	G3/8"X19	U3/4"X16	13.5	11	22	24	
2BJ-06-10	G3/8"X19	U7/8"X14	13.5	11	22	27	
2BJ-08	G1/2"X14	U3/4"X16	16	11	27	24	
2BJ-08-06	G1/2"X14	U9/16"X18	16	10	27	19	
2BJ-08-10	G1/2"X14	U7/8"X14	16	11	27	27	
2BJ-10	G5/8"X14	U7/8"X14	17.5	11	30	27	
2BJ-12	G3/4"X14	U1.1/16"X12	18.5	13.5	32	32	
2BJ-12-08	G3/4"X14	U3/4"X16	18.5	11	32	24	
2BJ-12-10	G3/4"X14	U7/8"X14	18.5	11	32	27	
2BJ-12-16	G3/4"X14	U1.5/16"X12	18.5	14.5	32	41	
2BJ-16	G1"X11	U1.5/16"X12	20.5	14.5	41	41	
2BJ-16-20	G1"X11	U1.5/8"X12	20.5	15.5	41	50	
2BJ-20	G1.1/4"X11	U1.5/8"X12	20.5	15.5	50	50	
2BJ-20-24	G1.1/4"X11	U1.7/8"X12	20.5	18.5	50	55	
2BJ-24	G1.1/2"X11	U1.7/8"X12	23	18.5	55	55	
2BJ-32	G2"X11	U2.1/2"X12	25.5	24.5	70	75	

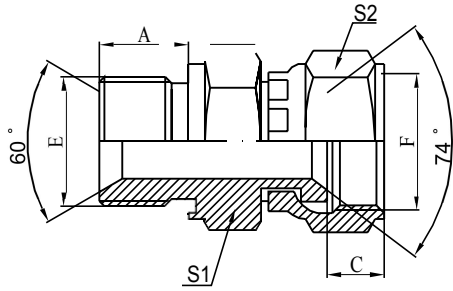

## 2BJ-WD

英管外螺纹胶垫密封/  
美制JIC内螺纹74°内锥  
BSP MALE CAPTIVE SEAL/  
JIC FEMALE 74° SEAT

代号 PART NO.	螺纹 THREADE		尺寸 DIMENSIONS				
	E	F	A	C	S1	S2	
2BJ-02-04WD	G1/8"X28	U7/16"X20	10	8.5	14	17	
2BJ-04-05WD	G1/4"X19	U1/2"X20	12	9.5	19	19	
2BJ-04-06WD	G1/4"X19	U9/16"X18	12	10	19	19	
2BJ-04-08WD	G1/4"X19	U3/4"X16	12	11	19	24	
2BJ-04WD	G1/4"X19	U7/16"X20	12	8.5	19	17	
2BJ-06-08WD	G3/8"X19	U3/4"X16	13.5	11	22	24	
2BJ-06WD	G3/8"X19	U9/16"X18	13.5	10	22	19	
2BJ-08-06WD	G1/2"X14	U9/16"X18	16	10	27	19	
2BJ-08-10WD	G1/2"X14	U7/8"X14	16	11	27	27	
2BJ-08WD	G1/2"X14	U3/4"X16	16	11	27	24	
2BJ-12-16WD	G3/4"X14	U1.5/16"X12	18.5	14.5	32	41	
2BJ-12WD	G3/4"X14	U1.1/16"X12	18.5	13.5	32	32	
2BJ-16WD	G1"X11	U1.5/16"X12	20.5	14.5	41	41	
2BJ-20-16WD	G1.1/4"X11	U1.5/16"X12	20.5	14.5	50	41	
2BJ-20WD	G1.1/4"X11	U1.5/8"X12	20.5	15.5	50	50	
2BJ-24WD	G1.1/2"X11	U1.7/8"X12	23	18.5	55	55	

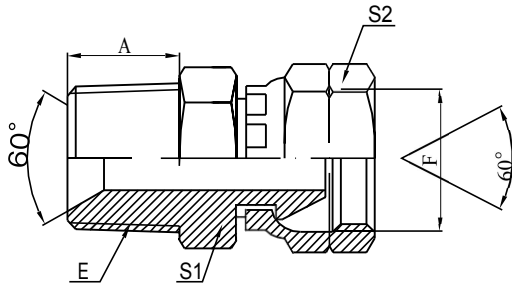

# 2TB

英锥管外螺纹/ 英管内螺纹60° 外锥  
BSPT MALE/BSP FEMALE 60° CONE

代号 PART NO.	螺纹 THREADE		尺寸 DIMENSIONS				
	E	F	A	C	S1	S2	
2TB-02	ZG1/8"X28	G1/8"X28	10	5.5	12	14	
2TB-02-04	ZG1/8"X28	G1/4"X19	10	5.5	14	19	
2TB-04	ZG1/4"X19	G1/4"X19	14	5.5	17	19	
2TB-04-06	ZG1/4"X19	G3/8"X19	14	6.5	17	22	
2TB-04-08	ZG1/4"X19	G1/2"X14	14	8	19	27	
2TB-06	ZG3/8"X19	G3/8"X19	14	6.5	19	22	
2TB-06-08	ZG3/8"X19	G1/2"X14	14	8	22	27	
2TB-08	ZG1/2"X14	G1/2"X14	19	8	22	27	
2TB-08-06	ZG1/2"X14	G3/8"X19	19	6.5	22	24	
2TB-08-12	ZG1/2"X14	G3/4"X14	19	11.5	27	32	
2TB-12	ZG3/4"X14	G3/4"X14	19.5	11.5	30	32	
2TB-12-16	ZG3/4"X14	G1"X11	19.5	11.5	32	41	
2TB-16	ZG1"X11	G1"X11	24	11.5	36	41	
2TB-16-20	ZG1"X11	G1.1/4"X11	24	12	41	50	
2TB-20	ZG1.1/4"X11	G1.1/4"X11	25	12	46	50	
2TB-24	ZG1.1/2"X11	G1.1/2"X11	25	13	50	55	
2TB-32	ZG2"X11	G2"X11	29	16	70	70	

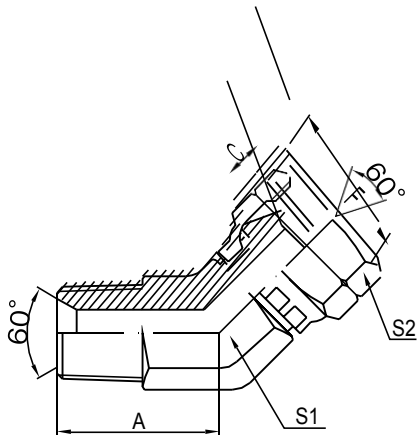

## 2TB4

45° 英锥管外螺纹/ 英管内螺纹60° 外锥  
45° BSPT MALE/BSP FEMALE 60° CONE

代号 PART NO.	螺纹 THREADS		尺寸 DIMENSIONS				
	E	F	A	C	S1	S2	
2TB4-02	ZG1/8"X28	G1/8"X28	20	5.5	11	14	
2TB4-04	ZG1/4"X19	G1/4"X19	22	5.5	14	19	
2TB4-06	ZG3/8"X19	G3/8"X19	22	6.5	17	22	
2TB4-08	ZG1/2"X14	G1/2"X14	27	8	22	27	
2TB4-12	ZG3/4"X14	G3/4"X14	33	11.5	27	32	
2TB4-16	ZG1"X11	G1"X11	37	11.5	33	41	
2NB4-20	ZG1.1/4"X11	G1.1/4"X11	40	12	44	50	
2NB4-24	ZG1.1/2"X11	G1.1/2"X11	47	13	53	55	

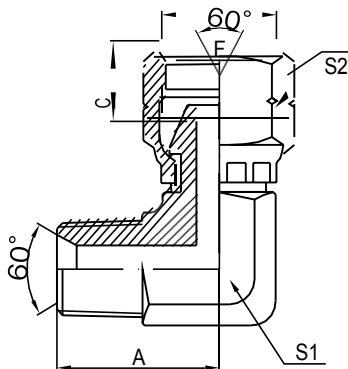

## 2TB9

90° 英锥管外螺纹/ 英管内螺纹60° 外锥  
90° BSPT MALE/BSP FEMALE 60° CONE

代号 PART NO.	螺纹 THREADS		尺寸 DIMENSIONS				
	E	F	A	C	S1	S2	
2TB9-02	ZG1/8"X28	G1/8"X28	23	5.5	11	14	
2TB9-04	ZG1/4"X19	G1/4"X19	29	5.5	14	19	
2TB9-06	ZG3/8"X19	G3/8"X19	30	6.5	17	22	
2TB9-08	ZG1/2"X14	G1/2"X14	37	8	22	27	
2TB9-12	ZG3/4"X14	G3/4"X14	40	11.5	27	32	
2TB9-16	ZG1"X11	G1"X11	49	11.5	33	41	
2NB9-20	ZG1.1/4"X11	G1.1/4"X11	57	12	44	50	
2NB9-24	ZG1.1/2"X11	G1.1/2"X11	57	13	48	55	

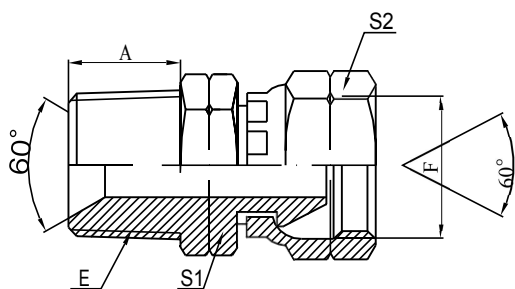

## 2NB

布锥管外螺纹/ 英管内螺纹60° 外锥  
NPT MALE/BSP FEMALE 60° CONE

代号 PART NO.	螺纹 THREADE		尺寸 DIMENSIONS				
	E	F	A	C	S1	S2	
2NB-02	Z1/8"X27	G1/8"X28	10	5.5	12	14	
2NB-02-04	Z1/8"X27	G1/4"X19	10	5.5	14	19	
2NB-04	Z1/4"X18	G1/4"X19	14	5.5	17	19	
2NB-04-06	Z1/4"X18	G3/8"X19	14	6.5	17	22	
2NB-04-08	Z1/4"X18	G1/2"X14	14	8	19	27	
2NB-06	Z3/8"X18	G3/8"X19	14	6.5	19	22	
2NB-06-08	Z3/8"X18	G1/2"X14	14	8	22	27	
2NB-08	Z1/2"X14	G1/2"X14	19	8	22	27	
2NB-08-06	Z1/2"X14	G3/8"X19	19	6.5	22	24	
2NB-08-12	Z1/2"X14	G3/4"X14	19	11.5	27	32	
2NB-12	Z3/4"X14	G3/4"X14	19.5	11.5	30	32	
2NB-12-16	Z3/4"X14	G1"X11	19.5	11.5	32	41	
2NB-16	Z1"X11.5	G1"X11	24	11.5	36	41	
2NB-16-20	Z1"X11.5	G1.1/4"X11	24	12	41	50	
2NB-20	Z1.1/4"X11.5	G1.1/4"X11	25	12	46	50	
2NB-24	Z1.1/2"X11.5	G1.1/2"X11	25	13	50	55	
2NB-32	Z2"X11.5	G2"X11	29	16	70	70	

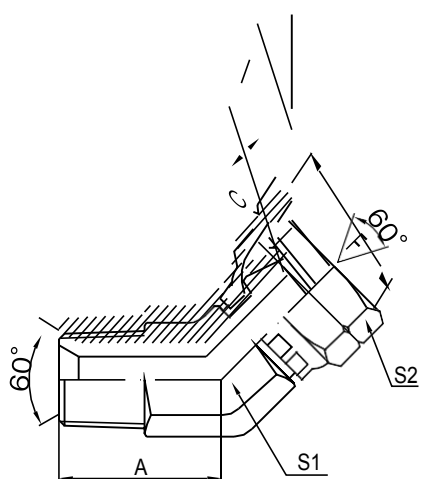

# 2NB4

45° 布锥管外螺纹/ 英管内螺纹60° 外锥  
45° NPT MALE/BSP FEMALE 60° CONE

代号 PART NO.	螺纹 THREADS		尺寸 DIMENSIONS				
	E	F	A	C	S1	S2	
2NB4-02	Z1/8"X27	G1/8"X28	20	5.5	11	14	
2NB4-04	Z1/4"X18	G1/4"X19	22	5.5	14	19	
2NB4-04-06	Z1/4"X18	G3/8"X19	22	6.5	17	22	
2NB4-06	Z3/8"X18	G3/8"X19	22	6.5	17	22	
2NB4-06-04	Z3/8"X18	G1/4"X19	22	5.5	17	19	
2NB4-06-08	Z3/8"X18	G1/2"X14	25	8	19	27	
2NB4-08	Z1/2"X14	G1/2"X14	27	8	22	27	
2NB4-08-06	Z1/2"X14	G3/8"X19	27	6.5	22	22	
2NB4-12	Z3/4"X14	G3/4"X14	33	11.5	27	32	
2NB4-12-08	Z3/4"X14	G1/2"X14	33	8	27	27	
2NB4-12-16	Z3/4"X14	G1"X11	37	11.5	33	41	
2NB4-16	Z1"X11.5	G1"X11	37	11.5	33	41	
2NB4-16-12	Z1"X11.5	G3/4"X14	37	11.5	33	32	
2NB4-20	Z1.1/4"X11.5	G1.1/4"X11	40	12	44	50	
2NB4-24	Z1.1/2"X11.5	G1.1/2"X11	47	13	53	55	
2NB4-32	Z2"X11.5	G2"X11	55	16	65	70	

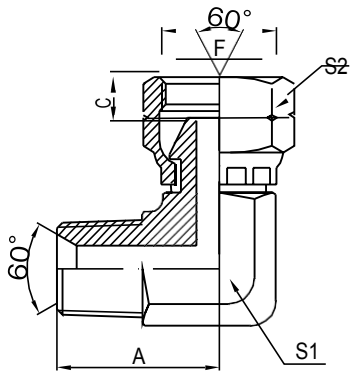

# 2NB9

90° 布锥管外螺纹/ 英管内螺纹60° 外锥  
90° NPT MALE/BSP FEMALE 60° CONE

代号 PART NO.	螺纹 THREADE		尺寸 DIMENSIONS				
	E	F	A	C	S1	S2	
2NB9-02	Z1/8"X27	G1/8"X28	23	5.5	11	14	
2NB9-04	Z1/4"X18	G1/4"X19	29	5.5	14	19	
2NB9-04-06	Z1/4"X18	G3/8"X19	30	6.5	17	22	
2NB9-06	Z3/8"X18	G3/8"X19	30	6.5	17	22	
2NB9-06-04	Z3/8"X18	G1/4"X19	30	5.5	17	19	
2NB9-06-08	Z3/8"X18	G1/2"X14	33	8	19	27	
2NB9-08	Z1/2"X14	G1/2"X14	37	8	22	27	
2NB9-08-06	Z1/2"X14	G3/8"X19	37	6.5	22	22	
2NB9-12	Z3/4"X14	G3/4"X14	40	11.5	27	32	
2NB9-12-08	Z3/4"X14	G1/2"X14	40	8	27	27	
2NB9-12-16	Z3/4"X14	G1"X11	49	11.5	33	41	
2NB9-16	Z1"X11.5	G1"X11	49	11.5	33	41	
2NB9-16-12	Z1"X11.5	G3/4"X14	49	11.5	33	32	
2NB9-20	Z1.1/4"X11.5	G1.1/4"X11	57	12	44	50	
2NB9-24	Z1.1/2"X11.5	G1.1/2"X11	57	13	48	55	
2NB9-32	Z2"X11.5	G2"X11	66	16	65	70	



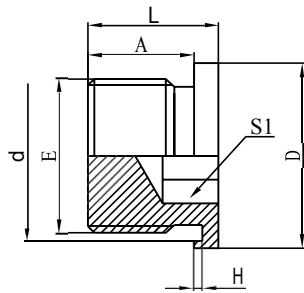

## 4BN-WD

英管外螺纹胶垫密封内六角堵头  
BSP MALE CAPTIVE SEAL HOLLOW HEX PLUG

代号 PART NO.	螺纹 THREADE			尺寸 DIMENSIONS					
	E			A	d	D	S1	H	L
4BN-04WD	G1/4"X19			12	16.3	19	6	1.2	17.3
4BN-06WD	G3/8"X19			12	18.7	22	8	1.2	17.3
4BN-08WD	G1/2"X14			14	23.7	27	10	1.2	19.3
4BN-12WD	G3/4"X14			16	29	32	12	1.2	21.3
4BN-16WD	G1"X11			16	35.5	40	14	1.6	22.8

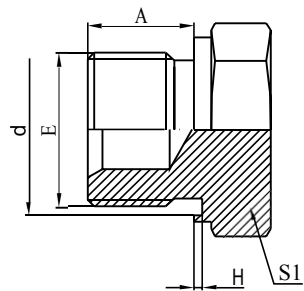

## 4B-WD

英管外螺纹胶垫密封堵头  
BSP MALE CAPTIVE SEAL PLUG

代号 PART NO.	螺纹 THREADE			尺寸 DIMENSIONS				
	E			A	d	S1	H	
4B-04WD	G1/4"X19			12	16.3	19	1.2	
4B-06WD	G3/8"X19			12	18.7	22	1.2	
4B-08WD	G1/2"X14			14	23.7	27	1.2	
4B-12WD	G3/4"X14			16	29	32	1.2	
4B-16WD	G1"X11			16	35.5	41	1.6	

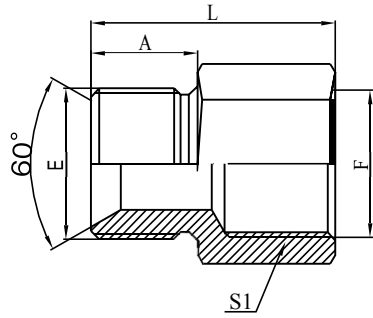

# 5B

英管外螺纹60°内锥或六角端面组合垫密封/英管内螺纹  
 BSP MALE DOUBLE FOR 60° SEAT  
 BONDED SEAL/BSP FEMALE

代号 PART NO.	螺纹 THREADS		尺寸 DIMENSIONS				
	E	F	A		S1		L
5B-02-04	G1/8"X28	G1/4"X19	10		19		28
5B-04-02	G1/4"X19	G1/8"X28	12		19		30
5B-04	G1/4"X19	G1/4"X19	12		19		30
5B-04-06	G1/4"X19	G3/8"X19	12		22		32
5B-06-04	G3/8"X19	G1/4"X19	13.5		22		33.5
5B-06	G3/8"X19	G3/8"X19	13.5		22		33.5
5B-06-08	G3/8"X19	G1/2"X14	13.5		27		33.5
5B-08-06	G1/2"X14	G3/8"X19	16		27		36
5B-08	G1/2"X14	G1/2"X14	16		27		36
5B-08-10	G1/2"X14	G5/8"X14	16		30		42
5B-08-12	G1/2"X14	G3/4"X14	16		32		40
5B-10-08	G5/8"X14	G1/2"X14	17.5		30		44
5B-12-08	G3/4"X14	G1/2"X14	18.5		32		43
5B-12	G3/4"X14	G3/4"X14	18.5		32		42.5
5B-12-16	G3/4"X14	G1"X11	18.5		41		52.5
5B-16-12	G1"X11	G3/4"X14	20.5		41		54.5
5B-16	G1"X11	G1"X11	20.5		41		54.5
5B-16-20	G1"X11	G1.1/4"X11	20.5		50		37.5
5B-20-16	G1.1/4"X11	G1"X11	20.5		50		57.5
5B-20	G1.1/4"X11	G1.1/4"X11	20.5		50		56.5
5B-20-24	G1.1/4"X11	G1.1/2"X11	20.5		55		57.5
5B-24	G1.1/2"X11	G1.1/2"X11	23		55		60
5B-32-24	G2"X11	G1.1/2"X11	23		70		60
5B-32	G2"X11	G2"X11	25.5		70		62.5

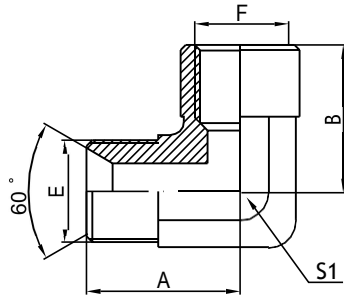

# 5B9

90° 英管外螺纹60° 内锥/ 英管内螺纹  
 90° BSP MALE 60° SEAT/BSP FEMALE

代号 PART NO.	螺纹 THREADE		尺寸 DIMENSIONS				
	E	F	A	B	S1		
5B9-02	G1/8"X28	G1/4"X19	22	17	14		
5B9-04	G1/4"X19	G1/4"X19	27	21	17		
5B9-06	G3/8"X19	G3/8"X19	32	27	22		
5B9-08	G1/2"X14	G1/2"X14	35	30	27		
5B9-12	G3/4"X14	G3/4"X14	40	32	33		
5B9-16	G1"X11	G1"X11	49	38	41		

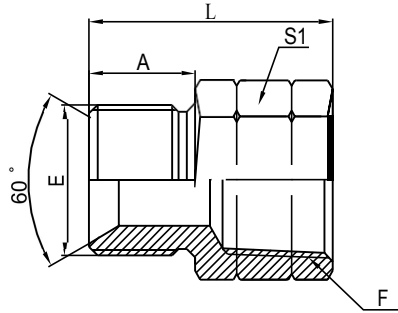

## 5BN

英管外螺纹60°内锥或六角端面组  
合垫密封/美制布锥管内螺纹  
BSP MALE DOUBLE FOR 60°EAT  
BONEDE SEAL/NPT FEMALE

代号 PART NO.	螺纹 THREADE		尺寸 DIMENSIONS				
	E	F	A	S1	L		
5BN-04	G1/4"X19	Z1/4"X18	12	19	30		
5BN-06	G3/8"X19	Z3/8"X18	13.5	22	33.5		
5BN-08	G1/2"X14	Z1/2"X14	16	27	36		
5BN-12	G3/4"X14	Z3/4"X14	18.5	32	42.5		
5BN-16	G1"X11	Z1"X11.5	20.5	41	54.5		
5BN-20	G1.1/4"X11	Z1.1 / 4"X11.5	20.5	50	57.5		
5BN-24	G1.1/2"X11	Z1.1 / 2"X11.5	23	55	60		
5BN-32	G2"X11	Z2"X11.5	25.5	70	62.5		

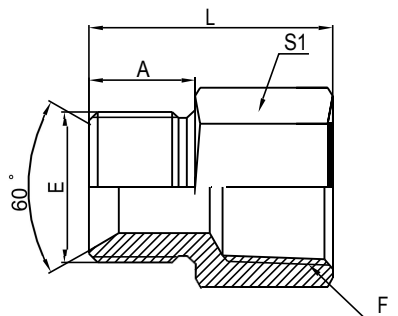

## 5BT

英管外螺纹60°内锥或六角端面组  
合垫密封/英锥管内螺纹  
BSP MALE DOUBLE FOR 60°EAT  
BONEDE SEAL/BSPT FEMALE

代号 PART NO.	螺纹 THREADE		尺寸 DIMENSIONS				
	E	F	A	S1	L		
5BT-04	G1/4"X19	ZG1/4"X19	12	19	30		
5BT-06	G3/8"X19	ZG3/8"X19	13.5	22	33.5		
5BT-08	G1/2"X14	ZG1/2"X14	16	27	36		
5BT-12	G3/4"X14	ZG3/4"X14	18.5	32	42.5		
5BT-16	G1"X11	ZG1"X11	20.5	41	54.5		
5BT-20	G1.1/4"X11	ZG1.1/4"X11	20.5	50	57.5		
5BT-24	G1.1/2"X11	ZG1.1/2"X11	23	55	60		
5BT-32	G2"X11	ZG2"X11	25.5	70	62.5		

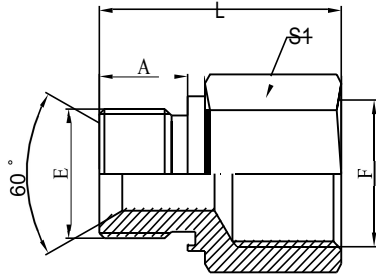

# 5B-WD

英管外螺纹胶垫密封/英管内螺纹  
BSP MALE CAPTIVE SEAL/BSP FEMALE

代号 PART NO.	螺纹 THREADS		尺寸 DIMENSIONS					
	E	F	A		S1		L	
5B-02-04WD	G1/8"X28	G1/4"X19	10		19		28	
5B-02-06WD	G1/8"X28	G3/8"X19	10		22		30	
5B-04-02WD	G1/4"X19	G1/8"X28	12		19		30	
5B-04-06WD	G1/4"X19	G3/8"X19	12		22		32	
5B-04-08WD	G1/4"X19	G1/2"X14	12		27		32	
5B-06-02WD	G3/8"X19	G1/8"X28	13.5		22		33.5	
5B-06-04WD	G3/8"X19	G1/4"X19	13.5		22		33.5	
5B-06-08WD	G3/8"X19	G1/2"X14	13.5		27		33.5	
5B-08-04WD	G1/2"X14	G1/4"X19	16		22		36	
5B-08-06WD	G1/2"X14	G3/8"X19	16		27		36	
5B-08-12WD	G1/2"X14	G3/4"X14	16		32		40	
5B-12-08WD	G3/4"X14	G1/2"X14	18.5		32		42.5	
5B-12-16WD	G3/4"X14	G1"X11	18.5		41		52.5	
5B-12-20WD	G3/4"X14	G1.1/4"X11	18.5		50		52.5	
5B-16-12WD	G1"X11	G3/4"X14	20.5		41		54.5	
5B-16-20WD	G1"X11	G1.1/4"X11	20.5		50		56.5	
5B-20-16WD	G1.1/4"X11	G1"X11	20.5		50		56.5	
5B-20-24WD	G1.1/4"X11	G1.1/2"X11	20.5		55		57.5	
5B-20-32WD	G1.1/4"X11	G2"X11	20.5		70		57.5	
5B-24-16WD	G1.1/2"X11	G1"X11	23		55		60	
5B-24-20WD	G1.1/2"X11	G1.1/4"X11	23		55		60	
5B-24-32WD	G1.1/2"X11	G2"X11	23		70		60	

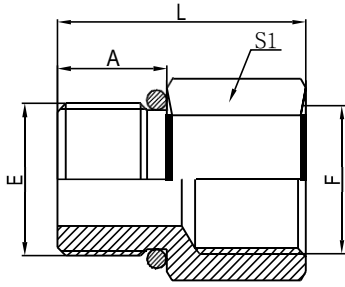

# 5GB

英管外螺纹O型圈/ 英管内螺纹  
BSP MALE O-RING/BSP FEMALE

代号 PART NO.	螺纹 THREADE		尺寸 DIMENSIONS				
	E	F	A	S1	L		
5GB-04	G1/4"X19	G1/4"X19	12	19	30		
5GB-04-06	G1/4"X19	G3/8"X19	12	22	32		
5GB-06	G3/8"X19	G3/8"X19	13.5	22	33.5		
5GB-06-08	G3/8"X19	G1/2"X14	13.5	27	33.5		
5GB-08	G1/2"X14	G1/2"X14	16	27	36		
5GB-08-12	G3/4"X14	G3/4"X14	16	32	40		
5GB-12	G3/4"X14	G3/4"X14	18.5	32	42.5		
5GB-12-16	G3/4"X14	G1"X11	18.5	41	52.5		
5GB-16-12	G1"X11	G3/4"X14	20.5	41	33		
5GB-16	G1"X11	G1"X11	20.5	41	54.5		

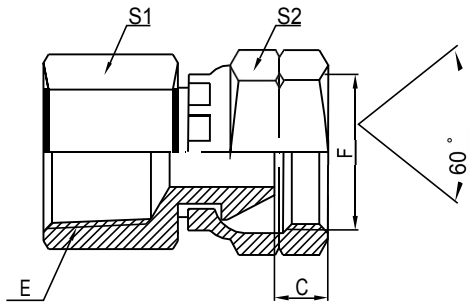

# 7TB

英锥管内螺纹/ 英管内螺纹60°外锥  
BSPT FEMALE/BSP FEMALE 60° CONE

代号 PART NO.	螺纹 THREADE		尺寸 DIMENSIONS				
	E	F	C	S1	S2		
7TB-02-04	ZG1/8"X28	G1/4"X19	5.5	17	19		
7TB-04	ZG1/4"X19	G1/4"X19	5.5	19	19		
7TB-04-06	ZG1/4"X19	G3/8"X19	6.5	22	22		
7TB-06	ZG3/8"X19	G3/8"X19	6.5	22	22		
7TB-06-08	ZG3/8"X19	G1/2"X14	8	27	27		
7TB-08-06	ZG1/2"X14	G3/8"X19	6.5	27	22		
7TB-08	ZG1/2"X14	G1/2"X14	8	27	27		
7TB-12	ZG3/4"X14	G3/4"X14	11.5	32	32		
7TB-16	ZG1"X11	G1"X11	11.5	41	41		

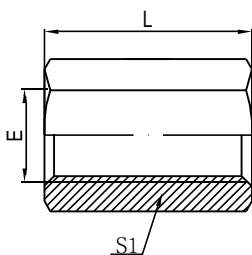

# 7B

英管内螺纹  
BSP FEMALE

代号 PART NO.	螺纹 THREADE		尺寸 DIMENSIONS						
	E	F				L		S1	
7B-02	G1/8"X28	G1/8"X28				22		14	
7B-04	G1/4"X19	G1/4"X19				24		19	
7B-06	G3/8"X19	G3/8"X19				26		22	
7B-08	G1/2"X14	G1/2"X14				32		27	
7B-10	G5/8"X14	G5/8"X14				36		30	
7B-12	G3/4"X14	G3/4"X14				36		32	
7B-16	G1"X11	G1"X11				40		41	
7B-20	G1.1/4"X11	G1.1/4"X11				44		50	
7B-24	G1.1/2"X11	G1.1/2"X11				45		55	
7B-32	G2"X11	G2"X11				54		70	

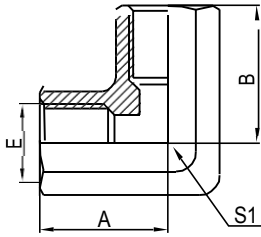

# 7B9

90° 英管内螺纹  
90° BSP FEMALE

代号 PART NO.	螺纹 THREADE				尺寸 DIMENSIONS B				
	E				A		S1		
7B9-02	G1/8"X28				17	17	14		
7B9-04	G1/4"X19				21	21	17		
7B9-06	G3/8"X19				24	24	22		
7B9-08	G1/2"X14				27	27	26		
7B9-12	G3/4"X14				33	33	34		
7B9-16	G1"X11				38	38	41		
7B9-20	G1.1/4"X11				45	45	54		
7B9-24	G1.1/2"X11				47	47	56		
7B9-32	G2"X11				60	60	68		

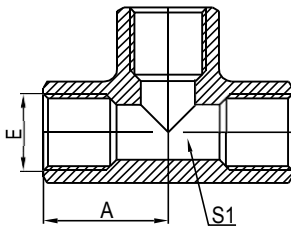

# GB

英管内螺纹三通  
BSP FEMALE TEE

代号 PART NO.	螺纹 THREADE				尺寸 DIMENSIONS				
	E				A		S1		
GB-02	G1/8"X28				17		14		
GB-04	G1/4"X19				21		17		
GB-06	G3/8"X19				24		22		
GB-08	G1/2"X14				27		26		
GB-12	G3/4"X14				33		34		
GB-16	G1"X11				38		41		
GB-20	G1.1/4"X11				45		54		
GB-24	G1.1/2"X11				47		56		
GB-32	G2"X11				60		68		



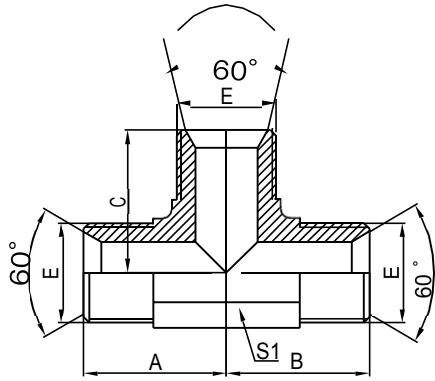

# AB

英管外螺纹60°内锥三通  
BSP MALE 60° SEAT TEE

代号 PART NO.	螺纹 THREADE			尺寸 DIMENSIONS				
	E	F	G	A	B	C	S1	
AB-02	G1/8"X28	G1/8"X28	G1/8"X28AB-	24	24	24	11	
04	G1/4"X19	G1/4"X19	G1/4"X19AB-	27	27	27	14	
06	G3/8"X19	G3/8"X19	G3/8"X19AB-	28	28	28	17	
08	G1/2"X14	G1/2"X14	G1/2"X14AB-	33	33	33	22	
10	G5/8"X14	G5/8"X14	G5/8"X14AB-	33	33	33	22	
12	G3/4"X14	G3/4"X14	G3/4"X14AB-	40	40	40	27	
16	G1"X11	G1"X11	G1"X11	49	49	49	33	
AB-20	G1.1/4"X11	G1.1/4"X11	G1.1/4"X11	57	57	57	44	

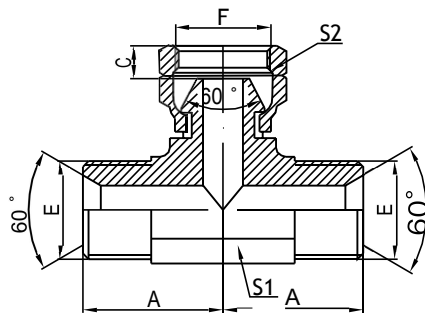

# BB

英管外螺纹60°内锥/  
英管内螺纹外锥分支三通  
BSP MALE 60° SEAT/  
BSP FEMALE 60° CONE BRANCH TEE

代号 PART NO.	螺纹 THREADE			尺寸 DIMENSIONS				
	E	F		A	C	S1	S2	
BB-02	G1/8"X28	G1/8"X28		24	5.5	11	14	
BB-04	G1/4"X19	G1/4"X19		27	5.5	14	19	
BB-06	G3/8"X19	G1/4"X19		28	6.5	17	22	
BB-08	G1/2"X14	G1/2"X14		33	8	22	27	
BB-12	G3/4"X14	G3/4"X14		40	11.5	27	32	
BB-16	G1"X11	G1"X11		49	11.5	33	41	
BB-20	G1.1/4"X11	G1.1/4"X11		57	12	44	50	

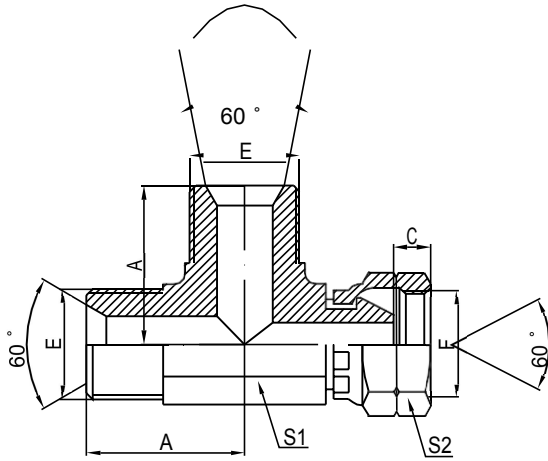

# CB

英管外螺纹60°内锥/  
 英管内螺纹外锥主支三通  
 BSP MALE 60° SEAT/  
 BSP FEMALE 60° CONE RUN TEE

代号 PART NO.	螺纹 THREADE			尺寸 DIMENSIONS			
	E	F		A	C	S1	S2
CB-02	G1/8"X28	G1/8"X28		24	5.5	11	14
CB-04	G1/4"X19	G1/4"X19		27	5.5	14	19
CB-06	G3/8"X19	G1/4"X19		28	6.5	17	22
CB-08	G1/2"X14	G1/2"X14		33	8	22	27
CB-12	G3/4"X14	G3/4"X14		40	11.5	27	32
CB-16	G1"X11	G1"X11		49	11.5	33	41
CB-20	G1.1/4"X11	G1.1/4"X11		57	12	44	50

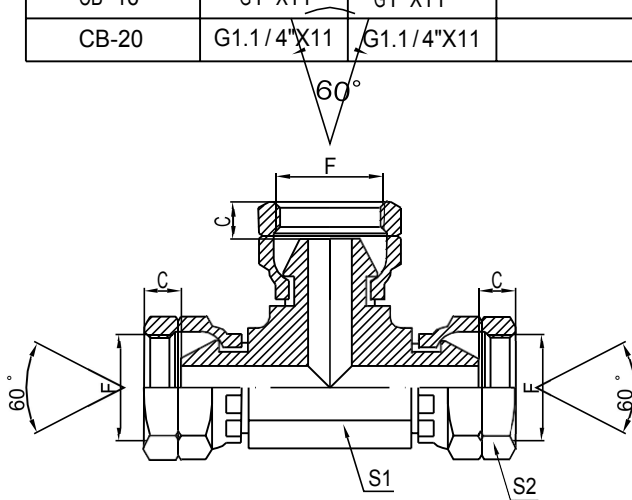

# DB

英管内螺纹外锥三通  
 BSP FEMALE 60° CONE TEE

代号 PART NO.	螺纹 THREADE			尺寸 DIMENSIONS			
	E	F		C	S1	S2	
DB-02	G1/8"X28	G1/8"X28		5.5	11	14	
DB-04	G1/4"X19	G1/4"X19		5.5	14	19	
DB-06	G3/8"X19	G1/4"X19		6.5	17	22	
DB-08	G1/2"X14	G1/2"X14		8	22	27	
DB-12	G3/4"X14	G3/4"X14		11.5	27	32	
DB-16	G1"X11	G1"X11		11.5	33	41	
DB-20	G1.1/4"X11	G1.1/4"X11		12	44	50	

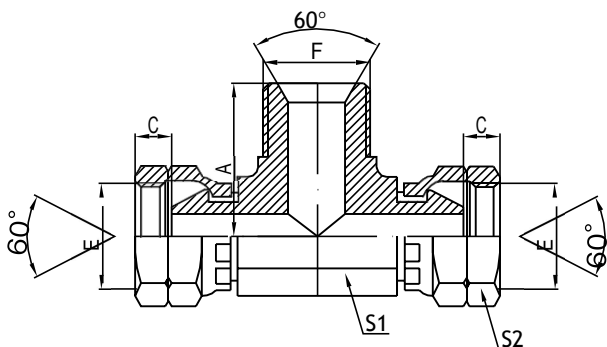

# EB

英管内螺纹60°外锥/  
 英管外螺纹60°内锥分支三通  
 BSP FEMALE 60° CONE/  
 BSP MALE 60° BRANCH TEE

代号 PART NO.	螺纹 THREADE		尺寸 DIMENSIONS				
	E	F	A	C	S1	S2	
EB-02	G1/8"X28	G1/8"X28	24	5.5	11	14	
EB-04	G1/4"X19	G1/4"X19	27	5.5	14	19	
EB-06	G3/8"X19	G1/4"X19	28	6.5	17	22	
EB-08	G1/2"X14	G1/2"X14	33	8	22	27	
EB-12	G3/4"X14	G3/4"X14	40	11.5	27	32	
EB-16	G1"X11	G1"X11	49	11.5	33	41	
EB-20	G1.1/4"X11	G1.1/4"X11	57	12	44	50	

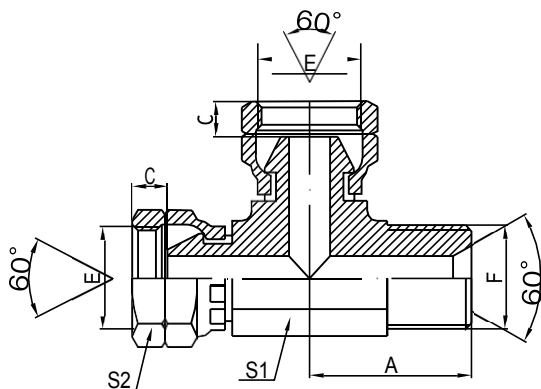

# FB

英管内螺纹60°外锥/  
 英管外螺纹60°内锥分支三通  
 BSP FEMALE 60° CONE/  
 BSP MALE 60° BRANCH TEE

代号 PART NO.	螺纹 THREADE		尺寸 DIMENSIONS				
	E	F	A	C	S1	S2	
FB-02	G1/8"X28	G1/8"X28	24	5.5	11	14	
FB-04	G1/4"X19	G1/4"X19	27	5.5	14	19	
FB-06	G3/8"X19	G1/4"X19	28	6.5	17	22	
FB-08	G1/2"X14	G1/2"X14	33	8	22	27	
FB-12	G3/4"X14	G3/4"X14	40	11.5	27	32	
FB-16	G1"X11	G1"X11	49	11.5	33	41	
FB-20	G1.1/4"X11	G1.1/4"X11	57	12	44	50	

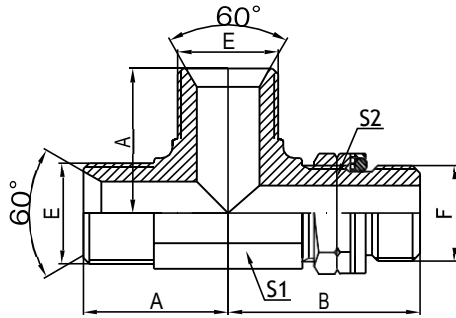

# ABBG-OG

英管外螺纹60°内锥/ 英管外螺纹O型圈可调向柱端主支三通  
 BSP MALE 60° SEAT/BSP MALE  
 O-RING ADJUSTABLE STUD END RUN TEE

代号 PART NO.	螺纹 THREADE			尺寸 DIMENSIONS				
	E	F	G	A	B	S1	S2	
ABBG-04OG	G1/4"X19	G1/4"X19	G1/4"X19	27	24.5	14	19	
ABBG-04-04-06OG	G1/4"X19	G1/4"X19	G3/8"X19	28	26.5	17	19	
ABBG-06OG	G3/8"X19	G3/8"X19	G3/8"X19	28	27.5	17	22	
ABBG-06-06-08OG	G3/8"X19	G3/8"X19	G1/2"X19	33	31	22	22	
ABBG-08OG	G1/2"X14	G1/2"X14	G1/2"X14	33	34.5	22	27	
ABBG-12OG	G3/4"X14	G3/4"X14	G3/4"X14	33	40	24	32	
ABBG-16OG	G1"X11	G1"X11	G1"X11	49	46	33	41	

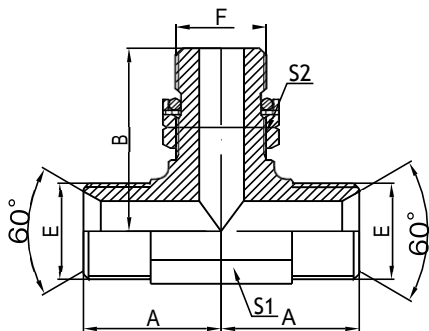

# ABGB-OG

英管外螺纹60°内锥/ 英管外螺纹O型圈可调向柱端分支三通  
 BSP MALE 60° SEAT/BSP MALE  
 O-RING ADJUSTABLE STUD END BRANCH TEE

代号 PART NO.	螺纹 THREADE			尺寸 DIMENSIONS				
	E	F	G	A	B	S1	S2	
ABGB-04OG	G1/4"X19	G1/4"X19	G1/4"X19	27	31.8	14	19	
ABGB-06-04-06OG	G1/4"X19	G1/4"X19	G3/8"X19	28	33.5	17	19	
ABGB-06OG	G3/8"X19	G3/8"X19	G3/8"X19	28	36.8	17	22	
ABGB-08-06-08OG	G3/8"X19	G3/8"X19	G1/2"X19	33	39.5	22	22	
ABGB-08OG	G1/2"X14	G1/2"X14	G1/2"X14	33	43.2	22	27	
ABGB-12-08-12OG	G3/4"X14	G1/2"X14	G3/4"X14	33	46.5	24	27	
ABGB-12OG	G3/4"X14	G3/4"X14	G3/4"X14	33	49.3	24	32	
ABGB-16OG	G1"X11	G1"X11	G1"X11	49	53	33	41	

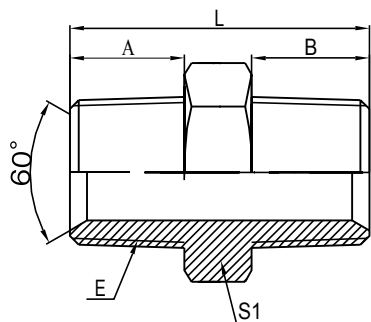

# 1T

英锥管外螺纹  
BSPT MALE

代号 PART NO.	螺纹 THREADS		尺寸 DIMENSIONS				
	E	F	A	B	S1	L	
1T-02	ZG1/8"X28	ZG1/8"X28	10	10	12	26	
1T-02-04	ZG1/8"X28	ZG1/4"X19	10	14	14	30	
1T-02-06	ZG1/8"X28	ZG3/8"X19	10	14	17	30	
1T-04	ZG1/4"X19	ZG1/4"X19	14	14	14	34	
1T-04-06	ZG1/4"X19	ZG3/8"X19	14	14	17	34	
1T-04-08	ZG1/4"X19	ZG1/2"X14	14	19	22	41.5	
1T-06	ZG3/8"X19	ZG3/8"X19	14	14	17	34	
1T-06-08	ZG3/8"X19	ZG1/2"X14	14	19	22	41	
1T-08	ZG1/2"X14	ZG1/2"X14	19	19	22	46	
1T-08-12	ZG1/2"X14	ZG3/4"X14	19	19.5	27	47	
1T-12	ZG3/4"X14	ZG3/4"X14	19.5	19.5	27	48	
1T-12-16	ZG3/4"X14	ZG1"X11	19.5	24	36	53	
1T-16	ZG1"X11	ZG1"X11	24	24	36	58	
1T-16-20	ZG1"X11	ZG1.1/4"X11	24	25	46	62	
1T-20	ZG1.1/4"X11	ZG1.1/4"X11	25	25	46	63	
1T-20-24	ZG1.1/4"X11	ZG1.1/2"X11	25	25	50	65	
1T-24	ZG1.1/2"X11	ZG1.1/2"X11	25	25	50	65	
1T-24-32	ZG1.1/2"X11	ZG2"X11	25	29	70	72	
1T-32	ZG2"X11	ZG2"X11	29	29	70	75	

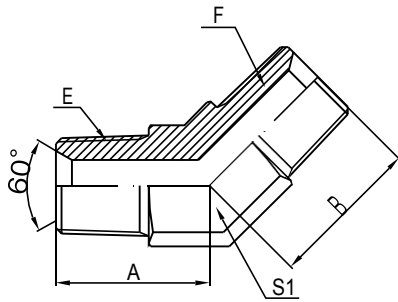

# 1T4

45° 英锥管外螺纹  
45° BSPT MALE

代号 PART NO.	螺纹 THREADE		尺寸 DIMENSIONS				
	E	F	A	B	S1		
1T4-02	ZG1/8"X28	ZG1/8"X28	19	21	11		
1T4-04	ZG1/4"X19	ZG1/4"X19	22	27	14		
1T4-06	ZG3/8"X19	ZG3/8"X19	22	29	17		
1T4-08	ZG1/2"X14	ZG1/2"X14	27	37	22		
1T4-12	ZG3/4"X14	ZG3/4"X14	33	43	27		
1T4-16	ZG1"X11	ZG1"X11	37	47	33		
1T4-20	ZG1.1/4"X11	ZG1.1/4"X11	40	56	44		
1T4-24	ZG1.1/2"X11	ZG1.1/2"X11	47	57	53		
1T4-32	ZG2"X11	ZG2"X11	55	63	65		

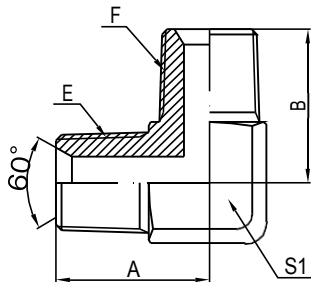

# 1T9

90° 英锥管外螺纹  
90° BSPT MALE

代号 PART NO.	螺纹 THREADE		尺寸 DIMENSIONS				
	E	F	A	B	S1		
1T9-02	ZG1/8"X28	ZG1/8"X28	22	22	11		
1T9-04	ZG1/4"X19	ZG1/4"X19	29	27	14		
1T9-06	ZG3/8"X19	ZG3/8"X19	30	29	17		
1T9-08	ZG1/2"X14	ZG1/2"X14	37	37	22		
1T9-12	ZG3/4"X14	ZG3/4"X14	40	40	27		
1T9-16	ZG1"X11	ZG1"X11	49	49	33		
1T9-20	ZG1.1/4"X11	ZG1.1/4"X11	57	57	44		
1T9-24	ZG1.1/2"X11	ZG1.1/2"X11	57	57	48		
1T9-32	ZG2"X11	ZG2"X11	66	66	65		

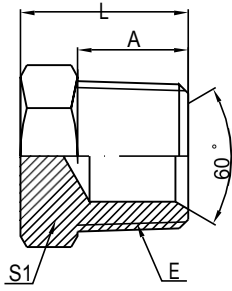

# 4T

英锥管外螺纹堵头  
BSPT MALE PLUG

代号 PART NO.	螺纹 THREADE				尺寸 DIMENSIONS				
	E				A		S1		L
4T-02	ZG1/8"X28				10		12		16
4T-04	ZG1/4"X19				14		17		20
4T-06	ZG3/8"X19				14		19		21
4T-08	ZG1/2"X14				19		22		27
4T-12	ZG3/4"X14				19.5		30		29
4T-16	ZG1"X11				24		36		36
4T-20	ZG1.1/4"X11				25		46		38
4T-24	ZG1.1/2"X11				25		50		41
4T-32	ZG2"X11				29		65		46

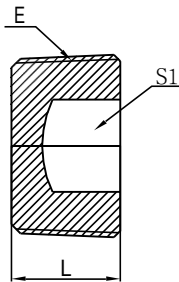

# 4TN

英锥管外螺纹内六角堵头  
BSPT MALE HOLLOW HEX PLUG

代号 PART NO.	螺纹 THREADE				尺寸 DIMENSIONS				
	E				L		S1		
4TN-02	ZG1/8"X28				8		5		
4TN-04	ZG1/4"X19				10		6		
4TN-06	ZG3/8"X19				12		8		
4TN-08	ZG1/2"X14				15		10		
4TN-12	ZG3/4"X14				18		12		
4TN-16	ZG1"X11				20		17		
4TN-20	ZG1.1/4"X11				22		22		

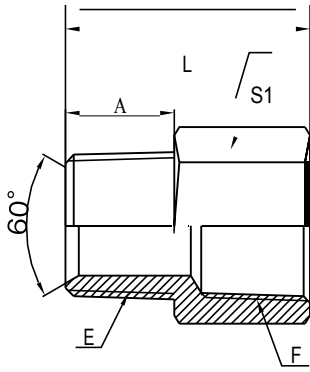

# 5T

英锥管外螺纹/ 英锥管内螺纹  
BSPT MALE/BSPT FEMALE

代号 PART NO.	螺纹 THREADE		尺寸 DIMENSIONS				
	E	F	A	S1	L		
5T-02	ZG1/8"X28	ZG1/8"X28	10	14	25		
5T-02-04	ZG1/8"X28	ZG1/4"X19	10	19	28		
5T-04-02	ZG1/4"X19	ZG1/8"X28	14	17	20		
5T-04	ZG1/4"X19	ZG1/4"X19	14	19	32		
5T-04-06	ZG1/4"X19	ZG3/8"X19	14	22	34		
5T-06-02	ZG3/8"X19	ZG1/8"X28	14	19	21		
5T-06-04	ZG3/8"X19	ZG1/4"X19	14	19	21		
5T-06-06	ZG3/8"X19	ZG3/8"X19	14	24	34		
5T-06-08	ZG3/8"X19	ZG1/2"X14	14	30	40		
5T-08-02	ZG1/2"X14	ZG3/4"X14	19	24	27		
5T-08-04	ZG1/2"X14	ZG1/4"X19	19	24	27		
5T-08-06	ZG1/2"X14	ZG3/8"X19	19	24	27		
5T-08-12	ZG1/2"X14	ZG3/4"X14	19	36	49		
5T-12-04	ZG3/4"X14	ZG1/4"X19	19.5	27	29		
5T-12-06	ZG3/4"X14	ZG3/8"X19	19.5	27	29		
5T-12-08	ZG3/4"X14	ZG1/2"X14	19.5	30	29		
5T-12-16	ZG3/4"X14	ZG1"X11	19.5	41	54		
5T-12-20	ZG3/4"X14	ZG1.1/4"X11	19.5	50	56		
5T-16-06	ZG1"X11	ZG3/8"X19	24	36	34		
5T-16-08	ZG1"X11	ZG1/2"X14	24	36	34		
5T-16-12	ZG1"X11	ZG3/4"X14	24	36	34		
5T-16-16	ZG1"X11	ZG1"X11	24	41	58		
5T-20-12	ZG1.1/4"X11	ZG3/4"X14	25	46	38		
5T-20-16	ZG1.1/4"X11	ZG1"X11	25	46	38		
5T-24-16	ZG1.1/2"X11	ZG1"X11	25	50	42		
5T-24-20	ZG1.1/2"X11	ZG1.1/4"X11	25	50	42		
5T-32-16	ZG2"X11	ZG1"X11	29	65	47		
5T-32-20	ZG2"X11	ZG1.1/4"X11	29	65	47		
5T-32-24	ZG2"X11	ZG1.1/2"X11	29	65	47		



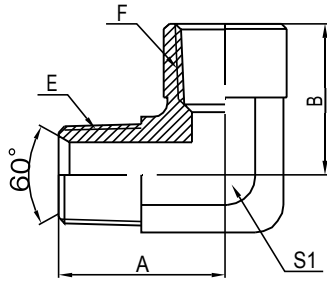

# 5T9

90° 英锥管外螺纹/ 英锥管内螺纹  
90° BSPT MALE/BSPT FEMALE

代号 PART NO.	螺纹 THREADE		尺寸 DIMENSIONS				
	E	F	A	B	S1		
5T9-02	ZG1/8"X28	ZG1/8"X28	30	23	17		
5T9-04	ZG1/4"X19	ZG1/4"X19	33	25	19		
5T9-06	ZG3/8"X19	ZG3/8"X19	37	25	22		
5T9-08	ZG1/2"X14	ZG1/2"X14	43	31.5	27		
5T9-12	ZG3/4"X14	ZG3/4"X14	52	37	33		
5T9-16	ZG1"X11	ZG1"X11	59	43	44		
5T9-20	ZG1.1/4"X11	ZG1.1/4"X11	61	50	50		
5T9-24	ZG1.1/2"X11	ZG1.1/2"X11	65	55	65		

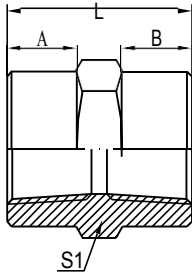

# 7T

英锥管内螺纹  
BSPT FEMALE

代号 PART NO.	螺纹 THREADE		尺寸 DIMENSIONS				
	E	F	A	B	S1	L	
7T-02	ZG1/8"X28	ZG1/8"X28	8	8	14	22	
7T-04-02	ZG1/4"X19	ZG1/8"X28	10	8	19	26	
7T-04	ZG1/4"X19	ZG1/4"X19	10	10	19	28	
7T-06-04	ZG3/8"X19	ZG1/4"X19	10	8	19	26	
7T-06	ZG3/8"X19	ZG3/8"X19	11	11	19	28	
7T-08-04	ZG1/2"X14	ZG1/4"X19	14	10	27	34	
7T-08	ZG1/2"X14	ZG1/2"X14	14	14	27	38	
7T-12	ZG3/4"X14	ZG3/4"X14	15.5	15.5	36	42	
7T-16	ZG1"X11	ZG1"X11	17	17	41	50	
7T-20	ZG1.1/4"X11	ZG1.1/4"X11	19	19	50	55	
7T-24	ZG1.1/2"X11	ZG1.1/2"X11	19	19	55	55	
7T-32	ZG2"X11	ZG2"X11	21	21	70	60	

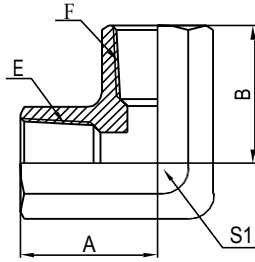

# 7T9

90° 英锥管内螺纹  
90° BSPT FEMALE

代号 PART NO.	螺纹 THREADE		尺寸 DIMENSIONS				
	E	F	A	B	S1		
7T9-02	ZG1/8"X28	ZG1/8"X28	17	17	14		
7T9-02-04	ZG1/8"X28	ZG1/4"X19	21	21	17		
7T9-04	ZG1/4"X19	ZG1/4"X19	21	21	17		
7T9-06	ZG3/8"X19	ZG3/8"X19	24	24	22		
7T9-08	ZG1/2"X14	ZG1/2"X14	27	27	26		
7T9-12	ZG3/4"X14	ZG3/4"X14	33	33	34		
7T9-16	ZG1"X11	ZG1"X11	38	38	41		
7T9-20	ZG1.1/4"X11	ZG1.1/4"X11	45	45	54		
7T9-24	ZG1.1/2"X11	ZG1.1/2"X11	47	47	56		
7T9-32	ZG2"X11	ZG2"X11	60	60	68		

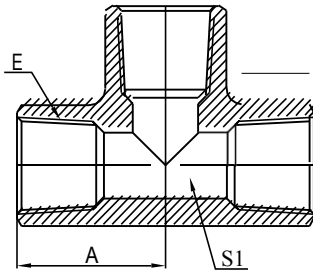

# GT

英锥管内螺纹三通  
BSPT FEMALE TEE

代号 PART NO.	螺纹 THREADE		尺寸 DIMENSIONS				
	E		A		S1		
GT-02	ZG1/8"X28		17		14		
GT-04	ZG1/4"X19		21		17		
GT-06	ZG3/8"X19		24		22		
GT-08	ZG1/2"X14		27		26		
GT-12	ZG3/4"X14		33		34		
GT-16	ZG1"X11		38		41		
GT-20	ZG1.1/4"X11		45		54		
GT-24	ZG1.1/2"X11		47		56		
GT-32	ZG2"X11		60		68		

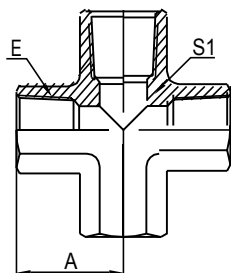

# ZT

英锥管内螺纹四通  
BSPT FEMALE CROSS

代号 PART NO.	螺纹 THREADE				尺寸 DIMENSIONS				
	E				A		S1		
ZT-02	ZG1/8"X28				17		14		
ZT-04	ZG1/4"X19				21		17		
ZT-06	ZG3/8"X19				24		22		
ZT-08	ZG1/2"X14				27		26		
ZT-12	ZG3/4"X14				33		34		
ZT-16	ZG1"X11				38		41		
ZT-20	ZG1.1/4"X11				45		54		

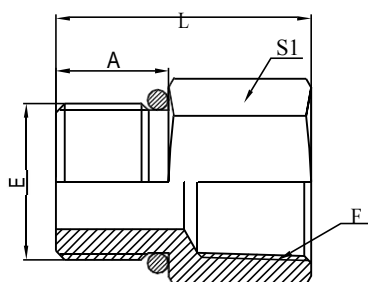

# 5GT

英管外螺纹O型圈/ 英锥管内螺纹  
BSP MALE O-RING/BSPT FEMALE

代号 PART NO.	螺纹 THREADE		尺寸 DIMENSIONS				
	E	F			A	S1	L
5GT-02	G1/8"X28	ZG1/8"X28			9	14	24
5GT-04	G1/4"X19	ZG1/4"X19			12	19	30
5GT-06	G3/8"X19	ZG3/8"X19			13.5	22	33.5
5GT-08-06	G1/2"X14	ZG3/8"X19			16	27	36
5GT-08	G1/2"X14	ZG1/2"X14			16	27	36
5GT-12	G3/4"X14	ZG3/4"X14			18.5	36	49
5GT-16	G1"X11	ZG1"X11			20.5	41	55

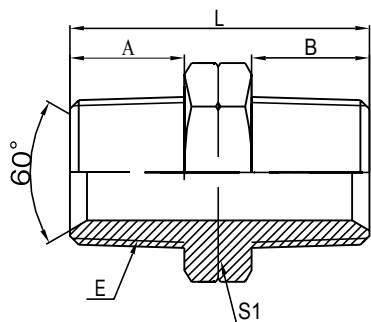

# 1N

美制布锥管外螺纹  
NPT MALE

代号 PART NO.	螺纹 THREADS		尺寸 DIMENSIONS				
	E	F	A	B	S1	L	
1N-02	Z1/8"X27	Z1/8"X27	10	10	12	26	
1N-02-04	Z1/8"X27	Z1/4"X18	10	14	14	30	
1N-02-06	Z1/8"X27	Z3/8"X18	10	14	17	30	
1N-04	Z1/4"X18	Z1/4"X18	14	14	14	34	
1N-04-06	Z1/4"X18	Z3/8"X18	14	14	17	34	
1N-04-08	Z1/4"X18	Z1/2"X14	14	19	22	41.5	
1N-06	Z3/8"X18	Z3/8"X18	14	14	17	34	
1N-06-08	Z3/8"X18	Z1/2"X14	14	19	22	41	
1N-08	Z1/2"X14	Z1/2"X14	19	19	22	46	
1N-08-12	Z1/2"X14	Z3/4"X14	19	19.5	27	47	
1N-12	Z3/4"X14	Z3/4"X14	19.5	19.5	27	48	
1N-12-16	Z3/4"X14	Z1"X11.5	19.5	24	36	53	
1N-16	Z1"X11.5	Z1"X11.5	24	24	36	58	
1N-16-20	Z1"X11.5	Z1.1/4"X11.5	24	25	46	62	
1N-20	Z1.1/4"X11.5	Z1.1/4"X11.5	25	25	46	63	
1N-20-24	Z1.1/4"X11.5	Z1.1/2"X11.5	25	25	50	65	
1N-24	Z1.1/2"X11.5	Z1.1/2"X11.5	25	25	50	65	
1N-24-32	Z1.1/2"X11.5	Z2"X11.5	25	29	70	72	
1N-32	Z2"X11.5	Z2"X11.5	29	29	70	75	

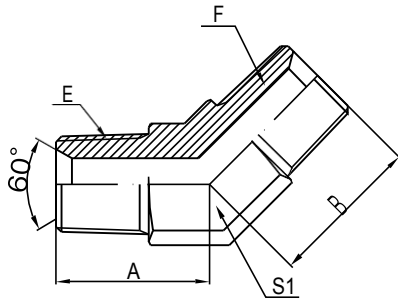

# 1N4

45° 美制布锥管外螺纹  
45° NPT MALE

代号 PART NO.	螺纹 THREADE		尺寸 DIMENSIONS				
	E	F	A	B	S1		
1N4-02	Z1/8"X27	Z1/8"X27	19	21	11		
1N4-04	Z1/4"X18	Z1/4"X18	22	27	14		
1N4-06	Z3/8"X18	Z3/8"X18	22	29	17		
1N4-08	Z1/2"X14	Z1/2"X14	27	37	22		
1N4-12	Z3/4"X14	Z3/4"X14	33	43	27		
1N4-16	Z1"X11.5	Z1"X11.5	37	47	33		
1N4-20	Z1.1/4"X11.5	Z1.1/4"X11.5	40	56	44		
1N4-24	Z1.1/2"X11.5	Z1.1/2"X11.5	47	57	53		
1N4-32	Z2"X11.5	Z2"X11.5	55	63	65		

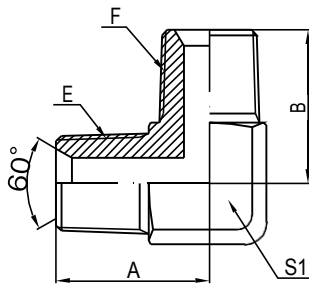

# 1N9

90° 美制布锥管外螺纹  
90° NPT MALE

代号 PART NO.	螺纹 THREADE		尺寸 DIMENSIONS				
	E	F	A	B	S1		
1N9-02	Z1/8"X27	Z1/8"X27	22	22	11		
1N9-04	Z1/4"X18	Z1/4"X18	29	27	14		
1N9-06	Z3/8"X18	Z3/8"X18	30	29	17		
1N9-08	Z1/2"X14	Z1/2"X14	37	37	22		
1N9-12	Z3/4"X14	Z3/4"X14	40	40	27		
1N9-16	Z1"X11.5	Z1"X11.5	49	49	33		
1N9-20	Z1.1/4"X11.5	Z1.1/4"X11.5	57	57	44		
1N9-24	Z1.1/2"X11.5	Z1.1/2"X11.5	57	57	48		
1N9-32	Z2"X11.5	Z2"X11.5	66	66	65		

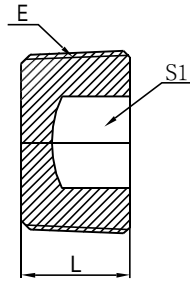

# 4NN

美制布锥管外螺纹内六角堵头  
NPT MALE HOLLOW HEX PLUG

代号 PART NO.	螺纹 THREADE				尺寸 DIMENSIONS				
	E				L		S1		
4NN-02	Z1/8"X27				8		5		
4NN-04	Z1/4"X18				10		6		
4NN-06	Z3/8"X18				12		8		
4NN-08	Z1/2"X14				15		10		
4NN-12	Z3/4"X14				18		12		
4NN-16	Z1"X11.5				20		17		

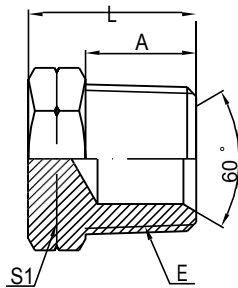

# 4N

美制布锥管外螺纹堵头  
NPT MALE PLUG

代号 PART NO.	螺纹 THREADE				尺寸 DIMENSIONS				
	E				A		S1		L
4N-02	Z1/8"X27				10		12		16
4N-04	Z1/4"X18				14		17		20
4N-06	Z3/8"X18				14		19		21
4N-08	Z1/2"X14				19		22		27
4N-12	Z3/4"X14				19.5		30		29
4N-16	Z1"X11.5				24		36		36
4N-20	Z1.1/4"X11.5				25		46		38
4N-24	Z1.1/2"X11.5				25		50		41
4N-32	Z2"X11.5				29		65		46

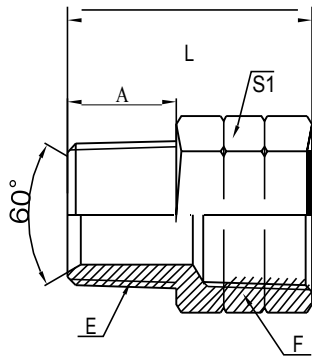

# 5N

美制布锥管外螺纹/布锥管内螺纹  
NPT MALE/NPT FEMALE

代号 PART NO.	螺纹 THREADE		尺寸 DIMENSIONS				
	E	F	A	S1	L		
5N-02	Z1/8"X27	Z1/8"X27	10	14	25		
5N-02-04	Z1/8"X27	Z1/4"X18	10	19	28		
5N-04-02	Z1/4"X18	Z1/8"X27	14	17	20		
5N-04	Z1/4"X18	Z1/4"X18	14	19	32		
5N-04-06	Z1/4"X18	Z3/8"X18	14	22	34		
5N-06-02	Z3/8"X18	Z1/8"X28	14	19	21		
5N-06-04	Z3/8"X18	Z1/4"X18	14	19	21		
5N-06-06	Z3/8"X18	Z3/8"X18	14	24	34		
5N-06-08	Z3/8"X18	Z1/2"X14	14	30	40		
5N-08-02	Z1/2"X14	Z3/4"X14	19	24	27		
5N-08-04	Z1/2"X14	Z1/4"X18	19	24	27		
5N-08-06	Z1/2"X14	Z3/8"X18	19	24	27		
5N-08-12	Z1/2"X14	Z3/4"X14	19	36	49		
5N-12-04	Z3/4"X14	Z1/4"X18	19.5	27	29		
5N-12-06	Z3/4"X14	Z3/8"X18	19.5	27	29		
5N-12-08	Z3/4"X14	Z1/2"X14	19.5	30	29		
5N-12-16	Z3/4"X14	Z1"X11.5	19.5	41	54		
5N-12-20	Z3/4"X14	Z1.1/4"X11.5	19.5	50	56		
5N-16-06	Z1"X11.5	Z3/8"X18	24	36	34		
5N-16-08	Z1"X11.5	Z1/2"X14	24	36	34		
5N-16-12	Z1"X11.5	Z3/4"X14	24	36	34		
5N-16-16	Z1"X11.5	Z1"X11.5	24	41	58		
5N-20-12	Z1.1/4"X11.5	Z3/4"X14	25	46	38		
5N-20-16	Z1.1/4"X11.5	Z1"X11.5	25	46	38		
5N-24-16	Z1.1/2"X11.5	Z1"X11.5	25	50	42		
5N-24-20	Z1.1/2"X11.5	Z1.1/4"X11.5	25	50	42		
5N-32-16	Z2"X11.5	Z1"X11.5	29	65	47		
5N-32-20	Z2"X11.5	Z1.1/4"X11.5	29	65	47		
5N-32-24	Z2"X11.5	Z1.1/2"X11.5	29	65	47		



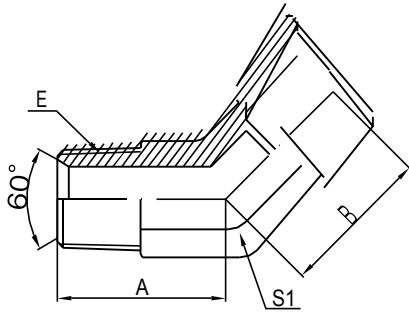

# 5N4

45° 美制布锥管外螺纹/ 布锥管内螺纹  
45° NPT MALE/NPT FEMALE

代号 PART NO.	螺纹 THREADE			尺寸 DIMENSIONS				
	E			A	B	S1		
5N4-02	Z1/8"X27			22	17	17		
5N4-04	Z1/4"X18			25	20	19		
5N4-06	Z3/8"X18			27	19	22		
5N4-08	Z1/2"X14			33	28	27		
5N4-12	Z3/4"X14			37	30	33		
5N4-16	Z1"X11.5			40	37.5	44		
5N4-20	Z1.1/4"X11.5			47	30	50		
5N4-24	Z1.1/2"X11.5			55	36	65		

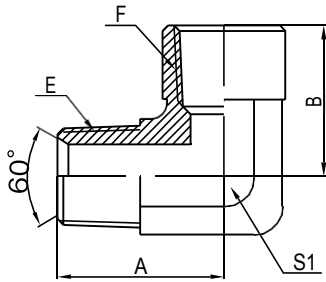

# 5N9

90° 美制布锥管外螺纹/ 布锥管内螺纹  
90° NPT MALE/NPT FEMALE

代号 PART NO.	螺纹 THREADE		尺寸 DIMENSIONS				
	E	F	A	B	S1		
5N9-02	Z1/8"X27	Z1/8"X27	22	17	14		
5N9-04-02	Z1/4"X18	Z1/8"X27	27	21	17		
5N9-04	Z1/4"X18	Z1/4"X18	27	21	17		
5N9-04-06	Z1/4"X18	Z3/8"X18	32	27	22		
5N9-06	Z3/8"X18	Z3/8"X18	32	27	22		
5N9-08	Z1/2"X14	Z1/2"X14	35	30	27		
5N9-12-08	Z3/4"X14	Z1/2"X14	40	32	33		
5N9-12	Z3/4"X14	Z3/4"X14	40	32	33		
5N9-16	Z1"X11.5	Z1"X11.5	49	38	41		
5N9-20	Z1.1/4"X11.5	Z1.1/4"X11.5	61	43.2	50		
5N9-24	Z1.1/2"X11.5	Z1.1/2"X11.5	65	52.8	65		
5N9-32	Z2"X11.5	Z2"X11.5	65	62	65		

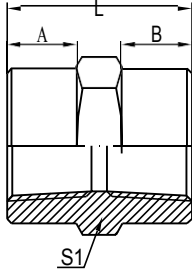

# 7N

美制布锥管内螺纹  
NPT FEMALE

代号 PART NO.	螺纹 THREADE		尺寸 DIMENSIONS					
	E	F			A	B	S1	L
7N-02	Z1/8"X27	Z1/8"X27			8	8	14	22
7N-04-02	Z1/4"X18	Z1/8"X27			10	8	19	26
7N-04	Z1/4"X18	Z1/4"X18			10	10	19	28
7N-06-04	Z3/8"X18	Z1/4"X18			10	8	19	26
7N-06	Z3/8"X18	Z3/8"X18			11	11	19	28
7N-08-04	Z1/2"X14	Z1/4"X18			14	10	27	34
7N-08	Z1/2"X14	Z1/2"X14			14	14	27	38
7N-12	Z3/4"X14	Z3/4"X14			15.5	15.5	36	42
7N-16	Z1"X11.5	Z1"X11.5			17	17	41	50
7N-20	Z1.1/4"X11.5	Z1.1/4"X11.5			19	19	50	55
7N-24	Z1.1/2"X11.5	Z1.1/2"X11.5			19	19	55	55
7N-32	Z2"X11.5	Z2"X11.5			21	21	70	60

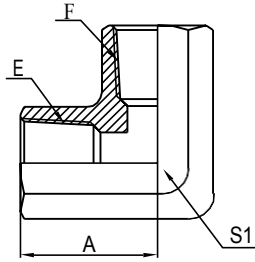

# 7N9

90° 美制布锥管内螺纹  
90° NPT FEMALE

代号 PART NO.	螺纹 THREADE		尺寸 DIMENSIONS			
	E	F	A	S1		
7N9-02	Z1/8"X27	Z1/8"X27	17	14		
7N9-02-04	Z1/8"X27	Z1/4"X18	21	17		
7N9-04	Z1/4"X18	Z1/4"X18	21	17		
7N9-06	Z3/8"X18	Z3/8"X18	24	22		
7N9-08	Z1/2"X14	Z1/2"X14	27	26		
7N9-12	Z3/4"X14	Z3/4"X14	33	34		
7N9-16	Z1"X11.5	Z1"X11.5	38	41		
7N9-20	Z1.1/4"X11.5	Z1.1/4"X11.5	45	54		
7N9-24	Z1.1/2"X11.5	Z1.1/2"X11.5	47	56		
7N9-32	Z2"X11.5	Z2"X11.5	60	68		

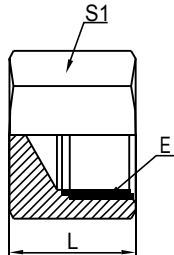

# 9N-CAP

美制布锥管内螺纹堵头  
NPT FEMALE PLUG

代号 PART NO.	螺纹 THREADE		尺寸 DIMENSIONS			
	E		A	S1		
9N-02CAP	Z1/8"X27		17.5	17		
9N-04CAP	Z1/4"X18		23	19		
9N-06CAP	Z3/8"X18		24	24		
9N-08CAP	Z1/2"X14		28	30		
9N-12CAP	Z3/4"X14		28	36		
9N-16CAP	Z1"X11.5		34	46		
9N-20CAP	Z1.1/4"X11.5		37	55		
9N-24CAP	Z1.1/2"X11.5		37	65		
9N-32CAP	Z2"X11.5		40.5	75		

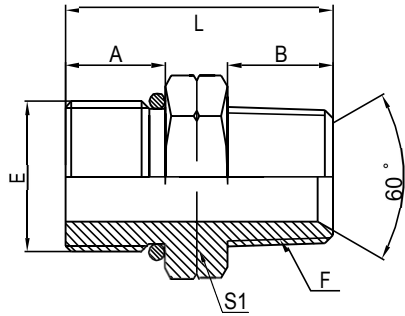

# 1NO

美制SAE外螺纹带O型圈/ 美制布锥管外螺纹  
NPT MALE/SAE O-RING BOSS

代号 PART NO.	螺纹 THREADE		尺寸 DIMENSIONS				
	E	F	A	B	S1	L	
1ON-04	U7/16"X20	Z1/4"X18	10	14	19	30	
1ON-04-06	U9/16"X18	Z1/4"X18	12	14	22	32	
1ON-06-04	U7/16"X20	Z3/8"X18	10	14	19	30	
1ON-06	U9/16"X18	Z3/8"X18	12	14	22	34	
1ON-06-08	U3/4"X16	Z3/8"X18	12	14	27	36	
1ON-08	U3/4"X16	Z1/2"X14	12	19	27	41	
1ON-08-10	U7/8"X14	Z1/2"X14	13.5	19	30	42.5	
1ON-08-12	U1.1/16"X12	Z1/2"X14	16	19	32	45	
1ON-12-10	U7/8"X14	Z3/4"X14	13.5	19.5	30	43	
1ON-12	U1.1/16"X12	Z3/4"X14	16	19.5	32	45.5	
1ON-16	U1.5/16"X12	Z1"X11.5	16	24	41	52	
1ON-20-16	U1.5/16"X12	Z1.1/4"X11.5	16	25	46	54	
1ON-20	U1.5/8"X12	Z1.1/4"X11.5	18	25	50	60	
1ON-24	U1.7/8"X12	Z1.1/2"X11.5	18.5	25	55	60.5	

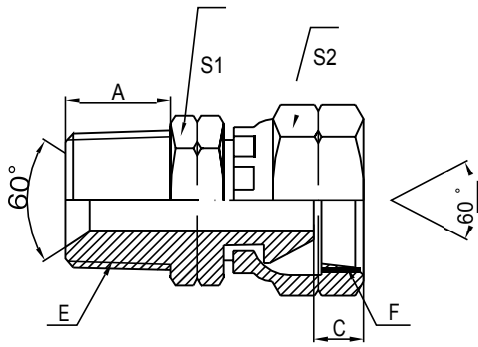

# 2NU

布锥管外螺纹/美制NPSM内螺纹60°外锥  
NPT MALE/NPSM FEMALE 60° CONE

代号 PART NO.	螺纹 THREADE		尺寸 DIMENSIONS				
	E	F	A	C	S1	S2	
2NU-02	Z1/8"X27	Z1/8"X27	10	5.5	12	14	
2NU-02-04	Z1/8"X27	Z1/4"X18	10	5.5	12	19	
2NU-04-02	Z1/4"X18	Z1/8"X27	14	5.5	14	14	
2NU-04	Z1/4"X18	Z1/4"X18	14	5.5	14	19	
2NU-04-06	Z1/4"X18	Z3/8"X18	14	6.5	17	22	
2NU-04-08	Z1/4"X18	Z1/2"X14	14	8	19	27	
2NU-06	Z3/8"X18	Z3/8"X18	14	6.5	19	22	
2NU-06-04	Z3/8"X18	Z1/4"X18	14	5.5	19	19	
2NU-06-08	Z3/8"X18	Z1/2"X14	14	8	19	27	
2NU-08	Z1/2"X14	Z1/2"X14	19	8	22	27	
2NU-08-04	Z1/2"X14	Z1/4"X18	19	5.5	22	19	
2NU-08-06	Z1/2"X14	Z3/8"X18	19	6.5	22	22	
2NU-12	Z3/4"X14	Z3/4"X14	19.5	11.5	27	32	
2NU-12-06	Z3/4"X14	Z3/8"X18	19.5	6.5	27	22	
2NU-12-08	Z3/4"X14	Z1/2"X14	19.5	8	27	27	
2NU-12-16	Z3/4"X14	Z1"X11.5	19.5	11.5	36	41	
2NU-16-12	Z1"X11.5	Z3/4"X14	24	11.5	36	32	
2NU-16	Z1"X11.5	Z1"X11.5	24	11.5	36	41	
2NU-16-20	Z1"X11.5	Z1.1/4"X11.5	24	12	41	50	
2NU-20-16	Z1.1/4"X11.5	Z1"X11.5	25	11.5	46	41	
2NU-20	Z1.1/4"X11.5	Z1.1/4"X11.5	25	12	46	50	
2NU-20-24	Z1.1/4"X11.5	Z1.1/2"X11.5	25	13	41	55	
2NU-24-20	Z1.1/2"X11.5	Z1.1/4"X11.5	25	12	46	50	
2NU-24	Z1.1/2"X11.5	Z1.1/2"X11.5	25	13	50	55	
2NU-32	Z2"X11.5	Z2"X11.5	29	16	65	70	

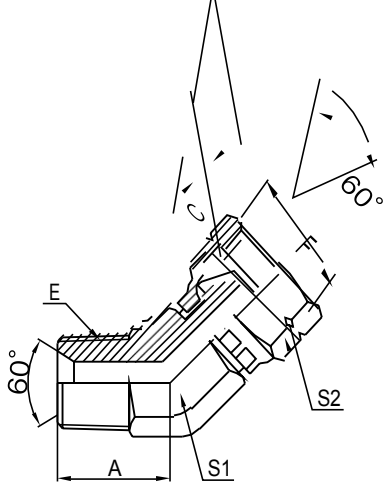

# 2NU4

45° 布锥管外螺纹/美制NPSM内螺纹60° 外锥  
45° NPT MALE/NPSM FEMALE 60° CONE

代号 PART NO.	螺纹 THREADE		尺寸 DIMENSIONS				
	E	F	A	C	S1	S2	
2NU4-02	Z1/8"X27	Z1/8"X27	17	5.5	11	14	
2NU4-04	Z1/4"X18	Z1/4"X18	22	5.5	14	19	
2NU4-04-06	Z1/4"X18	Z3/8"X18	22	6.5	17	22	
2NU4-06	Z3/8"X18	Z3/8"X18	22	6.5	17	22	
2NU4-06-04	Z3/8"X18	Z1/4"X18	22	5.5	17	19	
2NU4-06-08	Z3/8"X18	Z1/2"X14	25	8	19	27	
2NU4-08	Z1/2"X14	Z1/2"X14	27	8	22	27	
2NU4-08-06	Z1/2"X14	Z3/8"X18	27	6.5	22	22	
2NU4-08-12	Z1/2"X14	Z3/4"X14	33	11.5	27	32	
2NU4-12	Z3/4"X14	Z3/4"X14	33	11.5	27	32	
2NU4-12-08	Z3/4"X14	Z1/2"X14	33	8	27	27	
2NU4-12-16	Z3/4"X14	Z1"X11.5	37	11.5	33	41	
2NU4-16	Z1"X11.5	Z1"X11.5	37	11.5	33	41	
2NU4-16-12	Z1"X11.5	Z3/4"X14	37	11.5	33	32	
2NU4-20	Z1.1/4"X11.5	Z1.1/4"X11.5	40	12	44	50	
2NU4-24	Z1.1/2"X11.5	Z1.1/2"X11.5	47	13	50	55	
2NU4-32	Z2"X11.5	Z2"X11.5	55	16	65	70	

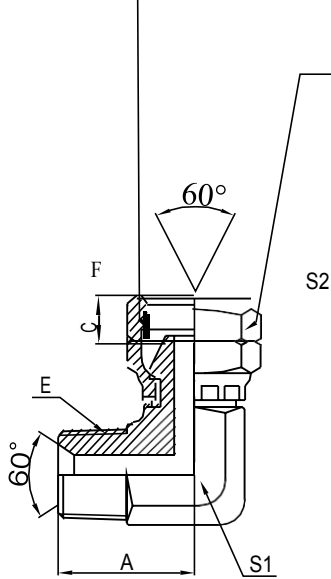

# 2NU9

90° 布锥管外螺纹/美制NPSM内螺纹60° 外锥  
90° NPT MALE/NPSM FEMALE 60° CONE

代号 PART NO.	螺纹 THREADS		尺寸 DIMENSIONS				
	E	F	A	C	S1	S2	
2NU9-02	Z1/8"X27	Z1/8"X27	21	5.5	11	14	
2NU9-02-04	Z1/8"X27	Z1/4"X18	21	5.5	11	19	
2NU9-04-02	Z1/4"X18	Z1/8"X27	29	5.5	14	14	
2NU9-04	Z1/4"X18	Z1/4"X18	29	5.5	14	19	
2NU9-04-06	Z1/4"X18	Z3/8"X18	30	6.5	17	22	
2NU9-06	Z3/8"X18	Z3/8"X18	30	6.5	17	22	
2NU9-06-04	Z3/8"X18	Z1/4"X18	30	5.5	17	19	
2NU9-06-08	Z3/8"X18	Z1/2"X14	33	8	19	27	
2NU9-08	Z1/2"X14	Z1/2"X14	37	8	22	27	
2NU9-08-06	Z1/2"X14	Z3/8"X18	37	6.5	22	22	
2NU9-08-12	Z1/2"X14	Z3/4"X14	43	11.5	27	32	
2NU9-12	Z3/4"X14	Z3/4"X14	43	11.5	27	32	
2NU9-12-08	Z3/4"X14	Z1/2"X14	43	8	27	27	
2NU9-12-16	Z3/4"X14	Z1"X11.5	52	11.5	33	41	
2NU9-16	Z1"X11.5	Z1"X11.5	52	11.5	33	41	
2NU9-16-12	Z1"X11.5	Z3/4"X14	52	11.5	33	32	
2NU9-20-16	Z1.1/4"X11.5	Z1"X11.5	59	11.5	44	41	
2NU9-20	Z1.1/4"X11.5	Z1.1/4"X11.5	59	12	44	50	
2NU9-24	Z1.1/2"X11.5	Z1.1/2"X11.5	61	13	50	55	
2NU9-32	Z2"X11.5	Z2"X11.5	66	16	65	70	

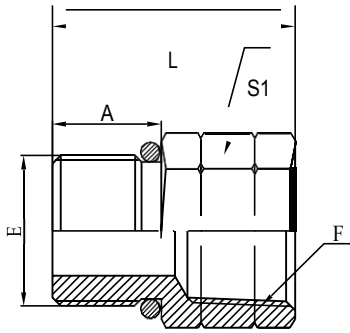

# 5GN

美制外螺纹O型圈/ 美制布锥管内螺纹  
BSP MALE O-RING/NPT FEMALE

代号 PART NO.	螺纹 THREADE		尺寸 DIMENSIONS				
	E	F	A	S1	L		
5GN-02	G1/8"X28	Z1/8"X27	9	17	24		
5GN-02-04	G1/8"X28	Z1/4"X18	9	19	27		
5GN-04-02	G1/4"X19	Z1/8"X27	12	19	30		
5GN-04	G1/4"X19	Z1/4"X18	12	19	30		
5GN-04-06	G1/4"X19	Z3/8"X18	12	22	32		
5GN-06-04	G3/8"X19	Z1/4"X18	13.5	22	33.5		
5GN-06	G3/8"X19	Z3/8"X18	13.5	22	33.5		
5GN-08-04	G1/2"X14	Z1/4"X18	16	27	36		
5GN-08-06	G1/2"X14	Z3/8"X18	16	27	36		
5GN-08	G1/2"X14	Z1/2"X14	16	30	42		
5GN-12	G3/4"X14	Z3/4"X14	18.5	36	48.5		
5GN-16	G1"X11	Z1"X11.5	20.5	41	54.5		
5GN-20	G1.1/4"X11	Z1.1/4"X11.5	20.5	50	57.5		
5GN-24	G1.1/2"X11	Z1.1/2"X11.5	23	60	60		



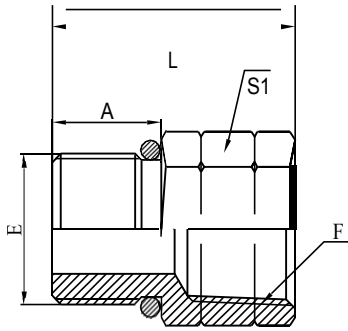

# 5HN

公制外螺纹轻系列/美制布锥管内螺纹  
METRIC MALE L-SERIES/NPT FEMALE

代号 PART NO.	螺纹 THREADE		尺寸 DIMENSIONS				
	E	F	A	S1	L		
5HN-10-02	M10x1	Z1/8"X27	8.5	14	23		
5HN-12-02	M12x1.5	Z1 / 8"X27	11	17	26		
5HN-12-04	M12x1.5	Z1 / 4"X18	11	19	29		
5HN-14-04	M14x1.5	Z1 / 4"X18	11	19	29		
5HN-16-06	M16x1.5	Z3 / 8"X18	11	22	31		
5HN-16-08	M16x1.5	Z1 / 2"X14	11	30	37		
5HN-18-06	M18x1.5	Z3 / 8"X18	11	24	31		
5HN-18-08	M18x1.5	Z1 / 2"X14	11	30	37		
5HN-22-08	M22x1.5	Z1/2"X14	12	30	38		
5HN-27-12	M27x2	Z3/4"X14	13	36	43		

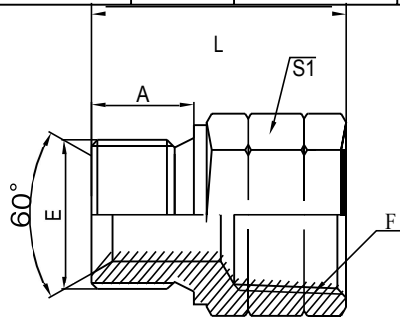

# 5MN

公制外螺纹组合垫圈/美制布锥管内螺纹  
METRIC MALE WITH BONDED SEAL/NPT FEMALE

代号 PART NO.	螺纹 THREADE		尺寸 DIMENSIONS				
	E	F	A	S1	L		
5MN-12-02	M12x1.5	Z1/8"X27	10	19	30		
5MN-14-04	M14x1.5	Z1/4"X18	11	19	31		
5MN-16-06	M16x1.5	Z3/8"X18	12	22	34		
5MN-18-06	M18x1.5	Z3/8"X18	12	24	34		
5MN-22-06	M22x1.5	Z3/8"X18	14	27	36		
5MN-22-08	M22x1.5	Z1/2"X14	14	30	43		

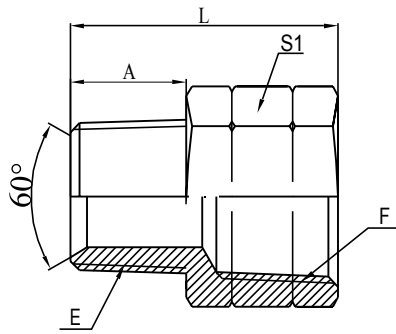

# 5NO

美制布锥管外螺纹/ 美制SAE内螺纹  
NPT MALE/SAE FEMALE

代号 PART NO.	螺纹 THREADS		尺寸 DIMENSIONS				
	E	F	A	S1	L		
5NO-02-04	Z1/8"X27	U7/16"X20	10	17	25		
5NO-02-05	Z1/8"X27	U1/2"X20	10	17	25		
5NO-04	Z1/4"X18	U7/16"X20	14	17	29		
5NO-04-06	Z1/4"X18	U9/16"X18	14	19	32		
5NO-04-08	Z1/4"X18	U3/4"X16	14	27	34		
5NO-06-04	Z3/8"X18	U7/16"X20	14	19	20		
5NO-06	Z3/8"X18	U9/16"X18	14	19	32		
5NO-06-08	Z3/8"X18	U3/4"X16	14	24	34		
5NO-08-06	Z1/2"X14	U9/16"X18	19	24	27		
5NO-08	Z1/2"X14	U3/4"X16	19	27	39		
5NO-08-10	Z1/2"X14	U7/8"X14	19	30	45		
5NO-12-08	Z3/4"X14	U3/4"X16	19.5	30	30		
5NO-12-10	Z3/4"X14	U7/8"X14	19.5	30	30		
5NO-12	Z3/4"X14	U1.1/16"X12	19.5	36	49		
5NO-16-12	Z1"X11.5	U1.1/16"X12	24	36	35		
5NO-16	Z1"X11.5	U1.5/16"X12	24	41	58		
5NO-20	Z1.1/4"X11.5	U1.5/8"X12	25	50	62		

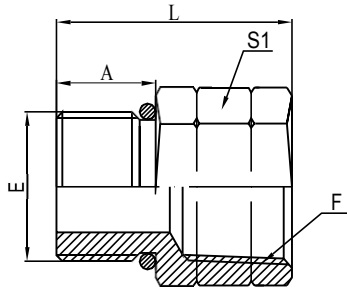

# 50N

美制SAE外螺纹O型圈轻系列/  
美制布锥管内螺纹  
SAE O-RING BOSS L-SERIES/  
NPT FEMALE

代号 PART NO.	螺纹 THREADS		尺寸 DIMENSIONS				
	E	F	A	S1	L		
50N-04-02	U7/16"X20	Z1/8"X27	10	17	25		
50N-04	U7/16"X20	Z1/4"X18	10	19	28		
50N-04-06	U7/16"X20	Z3/8"X18	10	24	30		
50N-05-02	U1/2"X20	Z1/8"X27	10	17	25		
50N-06-04	U9/16"X18	Z1/4"X18	12	19	30		
50N-08-04	U3/4"X16	Z1/4"X18	12	22	32		
50N-08-06	U3/4"X16	Z3/8"X18	12	22	32		
50N-08	U3/4"X16	Z1/2"X14	12	30	38		
50N-08-12	U3/4"X16	Z3/4"X14	12	36	42		
50N-10-08	U7/8"X14	Z1/2"X14	13.5	30	39		
50N-10-06	U7/8"X14	Z3/8"X18	13.5	27	33		
50N-10-12	U7/8"X14	Z3/4"X14	13.5	36	43		
50N-12-08	U1.1/16"X12	Z1/2"X14	16	32	40		
50N-12	U1.1/16"X12	Z3/4"X14	16	36	46		
50N-12-16	U1.1/16"X12	Z1"X11.5	16	41	50		
50N-16-12	U1.5/16"X12	Z3/4"X14	17	41	51		
50N-16	U1.5/16"X12	Z1"X11.5	17	41	51		
50N-20-16	U1.5/8"X12	Z1"X11.5	18	50	54		
50N-20	U1.5/8"X12	Z1.1/4"X11.5	18	50	54		
50N-24-16	U1.7/8"X12	Z1"X11.5	18.5	55	56		
50N-24-20	U1.7/8"X12	Z1.1/4"X11.5	18.5	55	56		
50N-24	U1.7/8"X12	Z1.1/2"X11.5	18.5	60	56		
50N-32	U1.1/2"X12	Z2"X11.5	22	70	59		

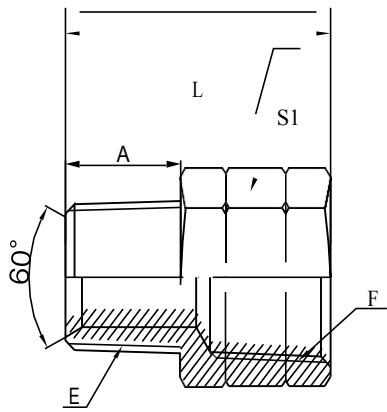

# 5TN

英锥管外螺纹/美制布锥管内螺纹  
BSPT MALE/NPT FEMALE

代号 PART NO.	螺纹 THREADS		尺寸 DIMENSIONS				
	E	F	A	S1	L		
5TN-02	ZG1/8"X28	Z1/8"X27	10	17	25		
5TN-04-02	ZG1/4"X19	Z1/8"X27	14	14	20		
5TN-04	ZG1/4"X19	Z1/4"X18	14	19	32		
5TN-06-04	ZG3/8"X19	Z1/4"X18	14	19	20		
5TN-06	ZG3/8"X19	Z3/8"X18	14	24	34		
5TN-08-06	ZG1/2"X14	Z3/8"X18	19	24	27		
5TN-08	ZG1/2"X14	Z1/2"X14	19	30	45		
5TN-12-08	ZG3/4"X14	Z1/2"X14	19.5	32	29		
5TN-12	ZG3/4"X14	Z3/4"X14	19.5	36	49		
5TN-16-12	ZG1"X11	Z3/4"X14	19.5	36	31		
5TN-16	ZG1"X11	Z1"X11.5	24	41	58		

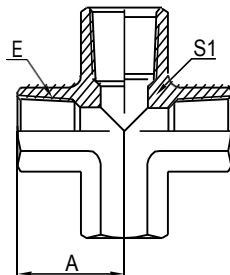

# ZN

美制布锥管内螺纹四通  
NPT FEMALE CROSS

代号 PART NO.	螺纹 THREADS		尺寸 DIMENSIONS				
	E		A	S1			
ZN-04	Z1/4"X18		21	17			
ZN-06	Z3/8"X18		24	22			
ZN-08	Z1/2"X14		27	26			
ZN-12	Z3/4"X14		33	34			
ZN-16	Z1"X11.5		38	41			
ZN-20	Z1.1/4"X11.5		45	54			

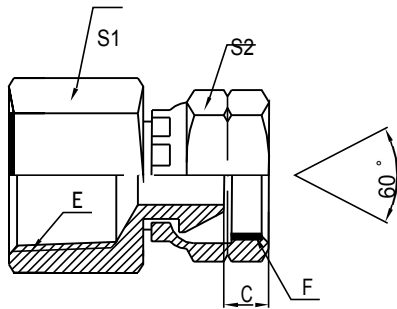

# 7NU

布锥管内螺纹/美制NPSM内螺纹60°外锥  
NPT FEMALE/NPSM FEMALE 60° CONE

代号 PART NO.	螺纹 THREADS		尺寸 DIMENSIONS				
	E	F	A	C	S1	S2	
7NU-02	Z1/8"X27	Z1/8"X27	10	5.5	17	14	
7NU-04-02	Z1/4"X18	Z1/8"X27	14	5.5	19	14	
7NU-04	Z1/4"X18	Z1/4"X18	14	5.5	19	19	
7NU-04-06	Z1/4"X18	Z3/8"X18	14	6.5	19	22	
7NU-06	Z3/8"X18	Z3/8"X18	14	6.5	22	22	
7NU-06-08	Z3/8"X18	Z1/2"X14	14	8	22	27	
7NU-08-06	Z1/2"X14	Z3/8"X18	19	6.5	30	22	
7NU-08	Z1/2"X14	Z1/2"X14	19	8	30	27	
7NU-12	Z3/4"X14	Z3/4"X14	19.5	11.5	36	32	
7NU-16	Z1"X11.5	Z1"X11.5	24	11.5	41	41	
7NU-20	Z1.1/4"X11.5	Z1.1/4"X11.5	25	12	50	50	
7NU-24	Z1.1/2"X11.5	Z1.1/2"X11.5	25	13	60	55	
7NU-32	Z2"X11.5	Z2"X11.5	29	16	70	70	

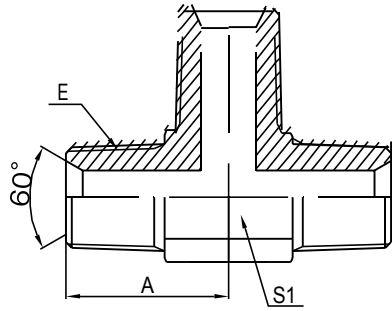

# AN

美制布锥管外螺纹三通  
NPT MALE TEE

代号 PART NO.	螺纹 THREADE				尺寸 DIMENSIONS			
	E				A		S1	
AN-02	Z1/8"X27				24		11	
AN-04	Z1/4"X18				27		14	
AN-06	Z3/8"X18				28		17	
AN-08	Z1/2"X14				33		22	
AN-12	Z3/4"X14				40		27	
AN-16	Z1"X11.5				49		33	
AN-20	Z1.1/4"X11.5				57		44	

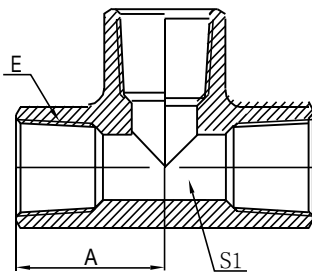

# GN

布锥管内螺纹三通  
NPT FEMALE TEE

代号 PART NO.	螺纹 THREADE				尺寸 DIMENSIONS			
	E				A		S1	
GN-02	Z1/8"X27				17		14	
GN-04	Z1/4"X18				21		17	
GN-06	Z3/8"X18				24		22	
GN-08	Z1/2"X14				27		26	
GN-12	Z3/4"X14				33		34	
GN-16	Z1"X11.5				38		41	
GN-20	Z1.1/4"X11.5				45		54	
GN-24	Z1.1/2"X11.5				47		56	
GN-32	Z2"X11.5				60		68	

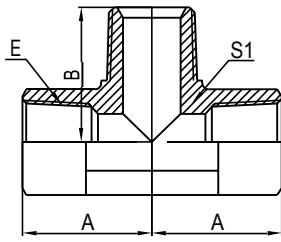

# JN

美制布锥管内螺纹/布锥管外螺纹分支三通  
NPT FEMALE/NPT MALE BRANCH TEE

代号 PART NO.	螺纹 THREADE		尺寸 DIMENSIONS				
	E	F	A	B	S1		
JN-02	Z1/8"X27	Z1/8"X27	17	17	14		
JN-04	Z1/4"X18	Z1/4"X18	21	21	17		
JN-06	Z3/8"X18	Z3/8"X18	24	24	22		
JN-08	Z1/2"X14	Z1/2"X14	27	27	26		
JN-12	Z3/4"X14	Z3/4"X14	33	33	34		
JN-16	Z1"X11.5	Z1"X11.5	38	38	41		

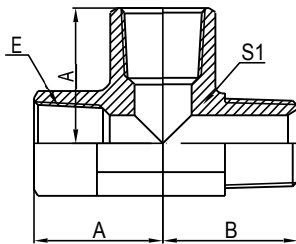

# HN

美制布锥管内螺纹/布锥管外螺纹主支三通  
NPT FEMALE/NPT MALE RUN TEE

代号 PART NO.	螺纹 THREADE		尺寸 DIMENSIONS				
	E	F	A	B	S1		
HN-02	Z1/8"X27	Z1/8"X27	17	17	14		
HN-04	Z1/4"X18	Z1/4"X18	21	21	17		
HN-06	Z3/8"X18	Z3/8"X18	24	24	22		
HN-08	Z1/2"X14	Z1/2"X14	27	27	26		
HN-12	Z3/4"X14	Z3/4"X14	33	33	34		
HN-16	Z1"X11.5	Z1"X11.5	38	38	41		

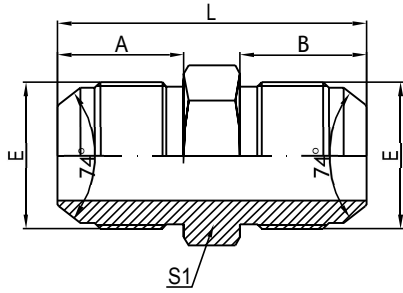

# 1J

美制JIC外螺纹74°外锥  
JIC MALE 74° CONE

代号 PART NO.	螺纹 THREADE		尺寸 DIMENSIONS				
	E	F	A	B	S1	L	
1J-02	U5/16"X24	U5/16"X24	11.5	11.5	12	29	
1J-04	U7/16"X20	U7/16"X20	14	14	14	34	
1J-04-05	U7/16"X20	U1/2"X20	14	14	14	34	
1J-04-06	U7/16"X20	U9/16"X18	14	14	17	34	
1J-04-08	U7/16"X20	U3/4"X16	14	16.7	22	39	
1J-05	U1/2"X20	U1/2"X20	14	14	14	34	
1J-05-06	U1/2"X20	U9/16"X18	14	14	17	35	
1J-05-08	U1/2"X20	U3/4"X16	14	16.7	22	39	
1J-05-10	U1/2"X20	U7/8"X14	14	19.5	24	42	
1J-06	U9/16"X18	U9/16"X18	14	14	17	35.5	
1J-06-08	U9/16"X18	U3/4"X16	14	16.7	22	38	
1J-06-10	U9/16"X18	U7/8"X14	14	19.5	24	42	
1J-06-12	U9/16"X18	U1.1/16"X12	14	22	30	46	
1J-08	U3/4"X16	U3/4"X16	16.7	16.7	22	42	
1J-08-10	U3/4"X16	U7/8"X14	16.7	19.5	24	44	
1J-08-12	U3/4"X16	U1.1/16"X12	16.7	22	30	49	
1J-08-16	U3/4"X16	U1.5/16"X12	16.7	23	36	51	
1J-10	U7/8"X14	U7/8"X14	19.5	19.5	24	47.5	
1J-10-12	U7/8"X14	U1.1/16"X12	19.5	22	30	52	
1J-10-16	U7/8"X14	U1.5/16"X12	19.5	23	36	53.5	
1J-12	U1.1/16"X12	U1.1/16"X12	22	22	30	55	
1J-12-16	U1.1/16"X12	U1.5/16"X12	22	23	36	56	
1J-16	U1.5/16"X12	U1.5/16"X12	23	23	36	57	
1J-16-20	U1.5/16"X12	U1.5/8"X12	23	24.5	46	60	
1J-20	U1.5/8"X12	U1.5/8"X12	24.5	24.5	46	61.5	
1J-20-24	U1.5/8"X12	U1.7/8"X12	24.5	27.5	50	66.5	
1J-20-32	U1.5/8"X12	U2.1/2"X12	24.5	34	70	75.5	
1J-24	U1.7/8"X12	U1.7/8"X12	27.5	27.5	50	69.5	
1J-24-32	U1.7/8"X12	U2.1/2"X12	27.5	34	70	78.5	
1J-32	U2.1/2"X12	U2.1/2"X12	34	34	70	85	



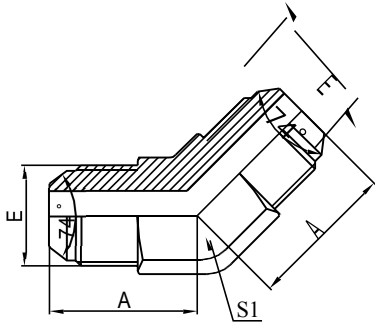

# 1J4

45° 美制JIC外螺纹74° 外锥  
45° JIC MALE 74° CONE

代号 PART NO.	螺纹 THREADE			尺寸 DIMENSIONS B				
	E			A		S1		
1J4-04	U7/16"X20			20	20	11		
1J4-05	U1/2"X20			22	22	14		
1J4-06	U9/16"X18			22	22	14		
1J4-08	U3/4"X16			25	25	19		
1J4-10	U7/8"X14			27	27	22		
1J4-12	U1.1/16"X12			33	33	27		
1J4-16	U1.5/16"X12			37	37	33		
1J4-20	U1.5/8"X12			40	40	44		
1J4-24	U1.7/8"X12			47	47	53		
1J4-32	U2.1/2"X12			55	55	65		

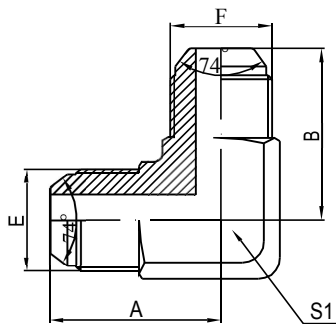

# 1J9

90° 美制JIC外螺纹74° 外锥  
90° JIC MALE 74° CONE

代号 PART NO.	螺纹 THREADE		尺寸 DIMENSIONS				
	E		A	B	S1		
1J9-04	U7/16"X20	U7/16"X20	22	22	11		
1J9-05	U1/2"X20	U1/2"X20	29	27	14		
1J9-06	U9/16"X18	U9/16"X18	29	27	14		
1J9-08	U3/4"X16	U3/4"X16	33	33	19		
1J9-10	U7/8"X14	U7/8"X14	37	37	22		
1J9-12	U1.1/16"X12	U1.1/16"X12	40	40	27		
1J9-16	U1.5/16"X12	U1.5/16"X12	49	49	33		
1J9-20	U1.5/8"X12	U1.5/8"X12	57	57	44		
1J9-24	U1.7/8"X12	U1.7/8"X12	57	57	48		
1J9-32	U2.1/2"X12	U2.1/2"X12	66	66	65		

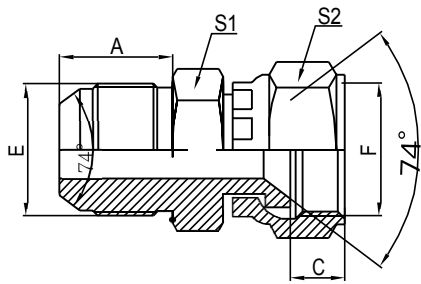

# 2J

美制JIC外螺纹74°外锥/  
JIC内螺纹74°内锥 JIC  
MALE 74° CONE/ JIC  
FEMALE 74° SEAT

代号 PART NO.	螺纹 THREADE		尺寸 DIMENSIONS				
	E	F	A	C	S1	S2	
2J-04	U7/16"X20	U7/16"X20	14	8.5	14	17	
2J-04-05	U7/16"X20	U1/2"X20	14	9.5	14	19	
2J-04-06	U7/16"X20	U9/16"X18	14	10	17	19	
2J-04-08	U7/16"X20	U3/4"X16	14	11	22	24	
2J-05	U1/2"X20	U1/2"X20	14	9.5	14	19	
2J-05-06	U1/2"X20	U9/16"X18	14	10	17	19	
2J-05-08	U1/2"X20	U3/4"X16	14	11	22	24	
2J-06	U9/16"X18	U9/16"X18	14	10	17	19	
2J-06-08	U9/16"X18	U3/4"X16	14	11	22	24	
2J-06-10	U9/16"X18	U7/8"X14	14	11	22	27	
2J-08	U3/4"X16	U3/4"X16	16.7	11	22	24	
2J-08-10	U3/4"X16	U7/8"X14	16.7	11	22	27	
2J-08-12	U3/4"X16	U1.1/16"X12	16.7	13.5	30	32	
2J-10	U7/8"X14	U7/8"X14	19.5	11	22	27	
2J-10-08	U7/8"X14	U3/4"X16	19.5	11	22	24	
2J-10-12	U7/8"X14	U1.1/16"X12	19.5	13.5	30	32	
2J-12	U1.1/16"X12	U1.1/16"X12	22	13.5	30	32	
2J-12-10	U1.1/16"X12	U7/8"X14	22	11	30	27	
2J-12-16	U1.1/16"X12	U1.5/16"X12	22	14.5	36	41	
2J-16	U1.5/16"X12	U1.5/16"X12	23	14.5	36	41	
2J-16-20	U1.5/16"X12	U1.5/8"X12	23	15.5	41	50	
2J-20	U1.5/8"X12	U1.5/8"X12	24.5	15.5	46	50	
2J-20-24	U1.5/8"X12	U1.7/8"X12	24.5	18.5	46	55	
2J-24	U1.7/8"X12	U1.7/8"X12	27.5	18.5	50	55	
2J-24-32	U1.7/8"X12	U2.1/2"X12	27.5	24.5	65	75	
2J-32	U2.1/2"X12	U2.1/2"X12	34	24.5	65	75	

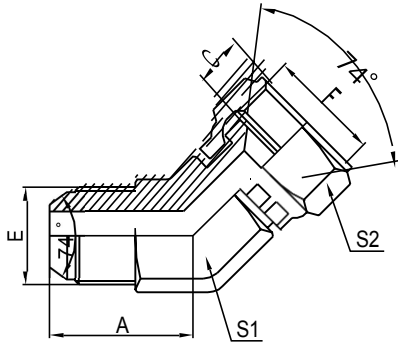

# 2J4

45° 美制JIC外螺纹74° 外锥/  
 JIC内螺纹74° 内锥 45°  
 JIC MALE 74° CONE/ JIC  
 FEMALE 74° SEAT

代号 PART NO.	螺纹 THREADE		尺寸 DIMENSIONS				
	E	F	A	C	S1	S2	
2J4-04	U7/16"X20	U7/16"X20	20	8.5	11	17	
2J4-05	U1/2"X20	U1/2"X20	22	9.5	14	19	
2J4-06	U9/16"X18	U9/16"X18	22	10	14	19	
2J4-08	U3/4"X16	U3/4"X16	25	11	19	24	
2J4-10	U7/8"X14	U7/8"X14	27	11	22	27	
2J4-12	U1.1/16"X12	U1.1/16"X12	33	13.5	27	32	
2J4-16	U1.5/16"X12	U1.5/16"X12	37	14.5	33	41	
2J4-20	U1.5/8"X12	U1.5/8"X12	40	15.5	44	50	
2J4-24	U1.7/8"X12	U1.7/8"X12	47	18.5	53	55	
2J4-32	U2.1/2"X12	U2.1/2"X12	55	24.5	65	75	

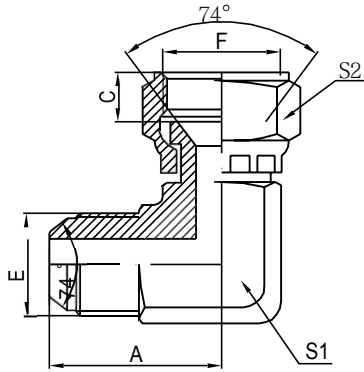

# 2J9

90° 美制JIC外螺纹74° 外锥/  
 JIC内螺纹74° 内锥 90°  
 JIC MALE 74° CONE/ JIC  
 FEMALE 74° SEAT

代号 PART NO.	螺纹 THREADS		尺寸 DIMENSIONS				
	E	F	A	C	S1	S2	
2J9-04	U7/16"X20	U7/16"X20	22	8.5	11	17	
2J9-05	U1/2"X20	U1/2"X20	29	9.5	14	19	
2J9-06	U9/16"X18	U9/16"X18	29	10	14	19	
2J9-06-08	U9/16"X18	U3/4"X16	33	11	19	24	
2J9-08-06	U3/4"X16	U9/16"X18	33	10	19	19	
2J9-08	U3/4"X16	U3/4"X16	33	11	19	24	
2J9-08-10	U3/4"X16	U7/8"X14	37	11	22	27	
2J9-10	U7/8"X14	U7/8"X14	37	11	22	27	
2J9-10-08	U7/8"X14	U3/4"X16	37	11	22	24	
2J9-10-12	U7/8"X14	U1.1/16"X12	40	13.5	27	32	
2J4-12	U1.1/16"X12	U1.1/16"X12	40	13.5	27	32	
2J4-12-10	U1.1/16"X12	U7/8"X14	40	11	27	27	
2J4-12-16	U1.1/16"X12	U1.5/16"X12	49	14.5	33	41	
2J9-16	U1.5/16"X12	U1.5/16"X12	49	14.5	33	41	
2J9-16-20	U1.5/16"X12	U1.5/8"X12	57	15.5	44	50	
2J9-20-16	U1.5/8"X12	U1.5/16"X12	57	14.5	44	41	
2J9-20	U1.5/8"X12	U1.5/8"X12	57	15.5	44	50	
2J9-20-24	U1.5/8"X12	U1.7/8"X12	57	18.5	48	55	
2J9-24-20	U1.7/8"X12	U1.5/8"X12	57	15.5	48	50	
2J9-24	U1.7/8"X12	U1.7/8"X12	57	18.5	48	55	
2J9-32	U2.1/2"X12	U2.1/2"X12	66	24.5	65	75	

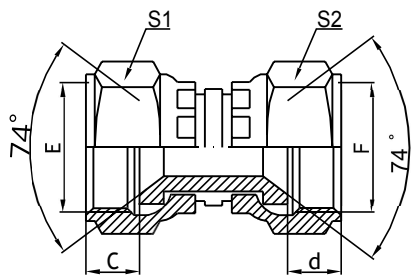

# 3J

美制JIC内螺纹74°内锥  
JIC FEMALE 74° SEAT

代号 PART NO.	螺纹 THREADE		尺寸 DIMENSIONS				
	E	F	C	d	S1	S2	
3J-04	U7/16"X20	U7/16"X20	8.5	8.5	17	17	
3J-05	U1/2"X20	U1/2"X20	9.5	9.5	19	19	
3J-06	U9/16"X18	U9/16"X18	10	10	19	19	
3J-06-08	U9/16"X18	U3/4"X16	10	11	19	24	
3J-08	U3/4"X16	U3/4"X16	11	11	24	24	
3J-10	U7/8"X14	U7/8"X14	11	11	27	27	
3J-12	U1.1/16"X12	U1.1/16"X12	13.5	13.5	32	32	
3J-16	U1.5/16"X12	U1.5/16"X12	14.5	14.5	41	41	
3J-20	U1.5/8"X12	U1.5/8"X12	15.5	15.5	50	50	
3J-24	U1.7/8"X12	U1.7/8"X12	18.5	18.5	55	55	

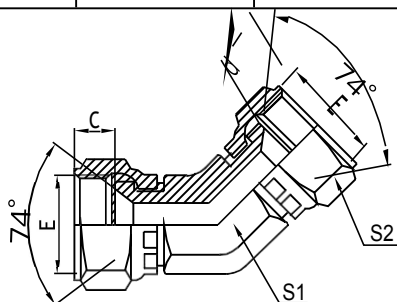

# 3J4

45°美制JIC内螺纹74°内锥  
45° JIC FEMALE 74° SEAT

代号 PART NO.	螺纹 THREADE		尺寸 DIMENSIONS				
	E	F	C	d	S1	S2	
3J4-04	U7/16"X20	U7/16"X20	8.5	8.5	17	17	
3J4-05	U1/2"X20	U1/2"X20	9.5	9.5	19	19	
3J4-06	U9/16"X18	U9/16"X18	10	10	19	19	
3J4-06-08	U9/16"X18	U3/4"X16	10	11	19	24	
3J4-08	U3/4"X16	U3/4"X16	11	11	24	24	
3J4-10	U7/8"X14	U7/8"X14	11	11	27	27	
3J4-12	U1.1/16"X12	U1.1/16"X12	13.5	13.5	32	32	
3J4-16	U1.5/16"X12	U1.5/16"X12	14.5	14.5	41	41	
3J4-20	U1.5/8"X12	U1.5/8"X12	15.5	15.5	50	50	
3J4-24	U1.7/8"X12	U1.7/8"X12	18.5	18.5	55	55	

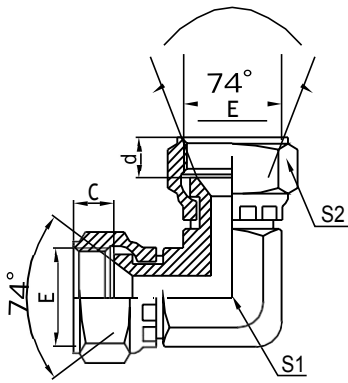

# 3J9

90° 美制JIC内螺纹74° 内锥  
90° JIC FEMALE 74° SEAT

代号 PART NO.	螺纹 THREADS		尺寸 DIMENSIONS				
	E	F	C	d	S1	S2	
3J9-04	U7/16"X20	U7/16"X20	8.5	8.5	17	17	
3J9-05	U1/2"X20	U1/2"X20	9.5	9.5	19	19	
3J9-06	U9/16"X18	U9/16"X18	10	10	19	19	
3J9-06-08	U9/16"X18	U3/4"X16	10	11	19	24	
3J9-08	U3/4"X16	U3/4"X16	11	11	24	24	
3J9-10	U7/8"X14	U7/8"X14	11	11	27	27	
3J9-12	U1.1/16"X12	U1.1/16"X12	13.5	13.5	32	32	
3J9-16	U1.5/16"X12	U1.5/16"X12	14.5	14.5	41	41	
3J9-20	U1.5/8"X12	U1.5/8"X12	15.5	15.5	50	50	
3J9-24	U1.7/8"X12	U1.7/8"X12	18.5	18.5	55	55	

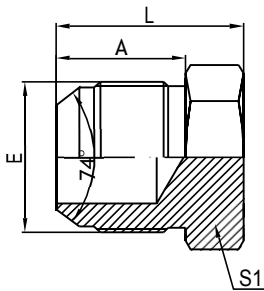

# 4J

美制JIC外螺纹74° 外锥堵头  
JIC MALE 74° CONE PLUG

代号 PART NO.	螺纹 THREADS		尺寸 DIMENSIONS			
	E		A	S1	L	
4J-04	U7/16"X20		14	14	20	
4J-05	U1/2"X20		14	14	20	
4J-06	U9/16"X18		14	17	20	
4J-08	U3/4"X16		16.7	22	25	
4J-10	U7/8"X14		19.5	24	28	
4J-12	U1.1/16"X12		22	30	31	
4J-16	U1.5/16"X12		23	36	34	
4J-20	U1.5/8"X12		24.5	46	38	
4J-24	U1.7/8"X12		27.5	50	44	
4J-32	U2.1/2"X12		34	65	52	

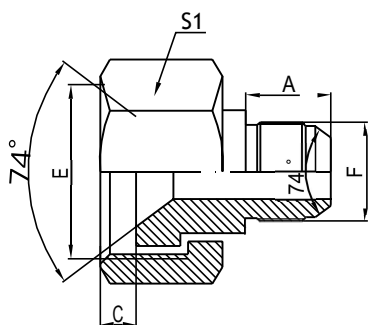

# 5J

美制JIC外螺纹/美制JIC内螺纹  
JIC MALE/JIC FEMALE

代号 PART NO.	螺纹 THREADS		尺寸 DIMENSIONS				
	E	F	A	C	S1		
5J-06-04	U9/16"X18	U7/16"X20	14	10	19		
5J-08-04	U3/4"X16	U7/16"X20	14	11	24		
5J-10-04	U7/8"X14	U7/16"X20	14	12	27		
5J-12-04	U1.1/16"X12	U7/16"X20	14	13	32		
5J-08-05	U3/4"X16	U1/2"X20	14	11	24		
5J-10-05	U7/8"X14	U1/2"X20	14	12	27		
5J-12-05	U1.1/16"X12	U1/2"X20	14	13	32		
5J-08-06	U3/4"X16	U9/16"X18	14	11	24		
5J-10-06	U7/8"X14	U9/16"X18	14	12	27		
5J-12-06	U1.1/16"X12	U9/16"X18	14	13	32		
5J-16-06	U1.5/16"X12	U9/16"X18	14	14	38		
5J-12-08	U1.1/16"X12	U3/4"X16	16.7	13	32		
5J-16-08	U1.5/16"X12	U3/4"X16	16.7	14	38		
5J-20-08	U1.5/8"X12	U3/4"X16	16.7	15	50		
5J-16-10	U1.5/16"X12	U7/8"X14	19.5	14	38		
5J-20-10	U1.5/8"X12	U7/8"X14	19.5	15	50		
5J-24-10	U1.7/8"X12	U7/8"X14	19.5	19	55		
5J-16-12	U1.5/16"X12	U1.1/16"X12	22	14	38		
5J-20-12	U1.5/8"X12	U1.1/16"X12	22	15	50		
5J-24-12	U1.7/8"X12	U1.1/16"X12	22	19	55		
5J-20-16	U1.5/8"X12	U1.5/16"X12	23	15	50		
5J-24-16	U1.7/8"X12	U1.5/16"X12	23	19	55		
5J-24-20	U1.7/8"X12	U1.5/8"X12	24.5	19	55		

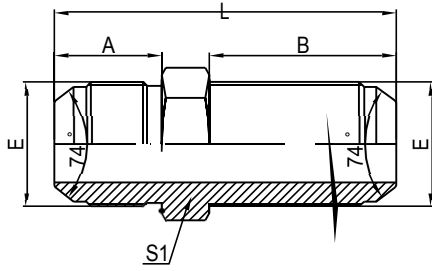

# 6J

美制JIC外螺纹74°外锥过板接头  
JIC MALE 74° CONE BULKHEAD

代号 PART NO.	螺纹 THREADE				尺寸 DIMENSIONS			
	E				A	B	S1	L
6J-04	U7/16"X20				14	32.5	17	53
6J-06	U9/16"X18				14	32.5	22	54
6J-08	U3/4"X16				16.7	36.5	24	61.5
6J-10	U7/8"X14				19.5	40	30	69.5
6J-12	U1.1/16"X12				22	44.5	36	78
6J-16	U1.5/16"X12				23	44.5	41	80
6J-20	U1.5/8"X12				24.5	45.7	50	84
6J-24	U1.7/8"X12				27.5	46	55	89
6J-32	U2.1/2"X12				34	53.1	70	105

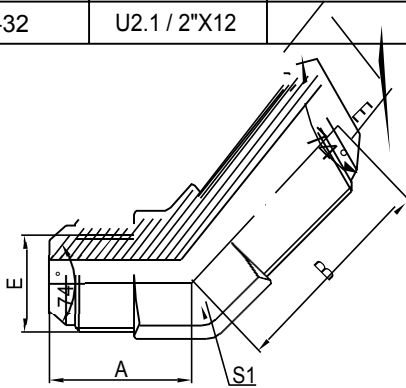

# 6J4

45°美制JIC外螺纹74°外锥过板接头  
45° JIC MALE 74° CONE BULKHEAD

代号 PART NO.	螺纹 THREADE				尺寸 DIMENSIONS			
	E				A	B	S1	
6J4-04	U7/16"X20				22	39	14	
6J4-06	U9/16"X18				22	42.5	14	
6J4-08	U3/4"X16				25	49.3	19	
6J4-10	U7/8"X14				27	55	22	
6J4-12	U1.1/16"X12				33	62	27	
6J4-16	U1.5/16"X12				37	65	33	
6J4-20	U1.5/8"X12				40	67.3	44	



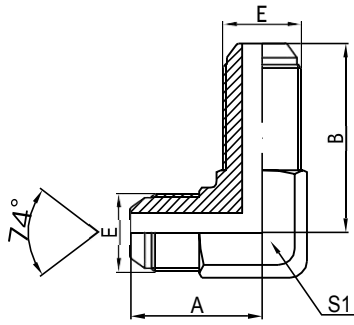

# 6J9

90° 美制JIC外螺纹74° 外锥过板接头  
90° JIC MALE 74° CONE BULKHEAD

代号 PART NO.	螺纹 THREADE				尺寸 DIMENSIONS				
	E				A	B	S1		
6J9-04	U7/16"X20				29	40.4	14		
6J9-06	U9/16"X18				29	46	14		
6J9-08	U3/4"X16				33	53.5	19		
6J9-10	U7/8"X14				37	60.7	22		
6J9-12	U1.1/16"X12				40	67.8	27		
6J9-16	U1.5/16"X12				49	71	33		
6J9-20	U1.5/8"X12				57	79.2	44		

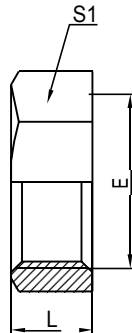

# 8J

美制JIC锁母  
JIC LOCK NUT

代号 PART NO.	螺纹 THREADE				尺寸 DIMENSIONS				
	E				L		S1		
8J-04	U7/16"X20				7		17		
8J-06	U9/16"X18				7		19		
8J-08	U3/4"X16				8		24		
8J-10	U7/8"X14				9		30		
8J-12	U1.1/16"X12				10.5		36		
8J-16	U1.5/16"X12				10.5		41		
8J-20	U1.5/8"X12				10.5		50		
8J-24	U1.7/8"X12				10.5		55		
8J-32	U2.1/2"X12				10.5		70		

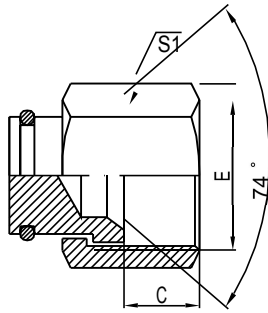

# 9J

美制JIC内螺纹74°内锥堵头  
JIC FEMALE 74° SEAT PLUG

代号 PART NO.	螺纹 THREADE		尺寸 DIMENSIONS				
	E	F	C		S1		
9J-04	U7/16"X20	U7/16"X20	9		17		
9J-06	U9/16"X18	U9/16"X18	10		19		
9J-08	U3/4"X16	U3/4"X16	11		24		
9J-10	U7/8"X14	U7/8"X14	12		27		
9J-12	U1.1/16"X12	U1.1/16"X12	13		32		
9J-16	U1.5/16"X12	U1.5/16"X12	14		38		
9J-20	U1.5/8"X12	U1.5/8"X12	15		50		
9J-24	U1.7/8"X12	U1.7/8"X12	19		55		
9J-32	U2.1/2"X12	U2.1/2"X12	24		75		

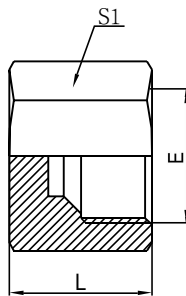

# 9J-CAP

JIC74°内螺纹堵头  
JIC 74° FEMALE PLUG

代号 PART NO.	螺纹 THREADE		尺寸 DIMENSIONS				
	E				S1	L	
9J-04CAP	U7/16"X20				14	15	
9J-06CAP	U9/16"X18				17	16	
9J-08CAP	U3/4"X16				22	19	
9J-10CAP	U7/8"X14				27	21.5	
9J-12CAP	U1.1/16"X12				32	23	
9J-16CAP	U1.5/16"X12				38	26	

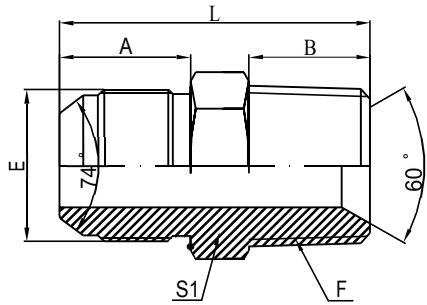

# 1JT

JIC外螺纹74°外锥/英锥管外螺纹  
JIC MALE 74° CONE/BSPT MALE

代号 PART NO.	螺纹 THREADE		尺寸 DIMENSIONS				
	E	F	A	B	S1	L	
1JT-04-02	U7/16"X20	ZG1/8"X28	14	10	14	30	
1JT-04	U7/16"X20	ZG1/4"X19	14	14	14	34	
1JT-04-06	U7/16"X20	ZG3/8"X19	14	14	19	34	
1JT-04-08	U7/16"X20	ZG1/2"X14	14	19	22	41.5	
1JT-05-04	U1/2"X20	ZG1/4"X19	14	14	14	34	
1JT-05-06	U1/2"X20	ZG3/8"X19	14	14	19	34	
1JT-05-08	U1/2"X20	ZG1/2"X14	14	19	22	41.5	
1JT-06-04	U9/16"X18	ZG1/4"X19	14	14	17	34	
1JT-06	U9/16"X18	ZG3/8"X19	14	14	19	34	
1JT-06-08	U9/16"X18	ZG1/2"X14	14	19	22	41	
1JT-08-04	U3/4"X16	ZG1/4"X19	16.7	14	22	39	
1JT-08-06	U3/4"X16	ZG3/8"X19	16.7	14	22	38	
1JT-08	U3/4"X16	ZG1/2"X14	16.7	19	22	44	
1JT-08-12	U3/4"X16	ZG3/4"X14	16.7	19.5	30	46	
1JT-10-06	U7/8"X14	ZG3/8"X19	19.5	14	24	42	
1JT-10-08	U7/8"X14	ZG1/2"X14	19.5	19	24	47	
1JT-10-12	U7/8"X14	ZG3/4"X14	19.5	19.5	30	48	
1JT-12-08	U1.1/16"X12	ZG1/2"X14	22	19	30	50	
1JT-12	U1.1/16"X12	ZG3/4"X14	22	19.5	30	50	
1JT-12-16	U1.1/16"X12	ZG1"X11	22	24	36	57	
1JT-12-20	U1.1/16"X12	ZG1.1/4"X11	22	25	46	60	
1JT-16-12	U1.5/16"X12	ZG3/4"X14	23	19.5	36	53	
1JT-16	U1.5/16"X12	ZG1"X11	23	24	36	58	
1JT-16-20	U1.5/16"X12	ZG1.1/4"X11	23	25	46	61	
1JT-16-24	U1.5/16"X12	ZG1.1/2"X11	23	25	50	64	
1JT-20-16	U1.5/8"X12	ZG1"X11	24.5	24	46	62	
1JT-20	U1.5/8"X12	ZG1.1/4"X11	24.5	25	46	63	
1JT-24	U1.7/8"X12	ZG1.1/2"X11	27.5	25	50	69	
1JT-24-32	U1.7/8"X12	ZG2"X11	27.5	29	70	74	
1JT-32	U2.1/2"X12	ZG2"X11	34	29	70	81	

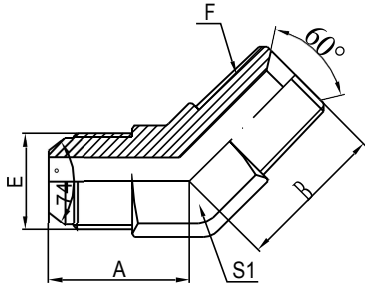

# 1JT4

45° JIC外螺纹74° 外锥/英锥管外螺纹  
45° JIC MALE 74° CONE/BSPT MALE

代号 PART NO.	螺纹 THREADE		尺寸 DIMENSIONS				
	E	F	A	B	S1		
1JT4-04-02	U7/16"X20	ZG1/8"X28	20	20	11		
1JT4-04	U7/16"X20	ZG1/4"X19	22	22	14		
1JT4-04-06	U7/16"X20	ZG3/8"X19	22	22	17		
1JT4-04-08	U7/16"X20	ZG1/2"X14	27	27	22		
1JT4-05-04	U1/2"X20	ZG1/4"X19	22	22	14		
1JT4-06-04	U9/16"X18	ZG1/4"X19	22	22	14		
1JT4-06	U9/16"X18	ZG3/8"X19	22	22	17		
1JT4-06-08	U9/16"X18	ZG1/2"X14	27	27	22		
1JT4-08-04	U3/4"X16	ZG1/4"X19	25	25	19		
1JT4-08-06	U3/4"X16	ZG3/8"X19	25	25	19		
1JT4-08	U3/4"X16	ZG1/2"X14	27	27	22		
1JT4-08-12	U3/4"X16	ZG3/4"X14	33	33	27		
1JT4-10-08	U7/8"X14	ZG1/2"X14	27	27	22		
1JT4-10-12	U7/8"X14	ZG3/4"X14	33	33	27		
1JT4-12-08	U1.1/16"X12	ZG1/2"X14	33	33	27		
1JT4-12	U1.1/16"X12	ZG3/4"X14	33	33	27		
1JT4-12-16	U1.1/16"X12	ZG1"X11	37	37	33		
1JT4-16-12	U1.5/16"X12	ZG3/4"X14	37	37	33		
1JT4-16	U1.5/16"X12	ZG1"X11	37	37	33		
1JT4-16-20	U1.5/16"X12	ZG1.1/4"X11	40	40	44		
1JT4-20-16	U1.5/8"X12	ZG1"X11	40	40	44		
1JT4-20	U1.5/8"X12	ZG1.1/4"X11	40	40	44		
1JT4-20-24	U1.7/8"X12	ZG1.1/2"X11	47	47	53		
1JT4-24	U1.7/8"X12	ZG1.1/2"X11	47	47	53		
1JT4-32	U2.1/2"X12	ZG2"X11	55	55	65		

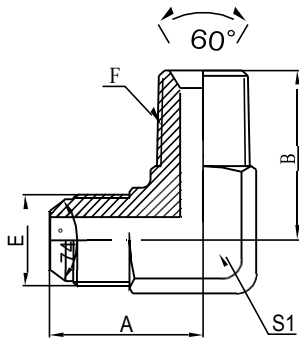

# 1JT9

90° JIC外螺纹 74° 外锥/英锥管外螺纹  
90° JIC MALE 74° CONE/BSPT MALE

代号 PART NO.	螺纹 THREADS		尺寸 DIMENSIONS				
	E	F	A	B	S1		
1JT9-04-02	U7/16"X20	ZG1/8"X28	22	22	11		
1JT9-04	U7/16"X20	ZG1/4"X19	29	27	14		
1JT9-04-06	U7/16"X20	ZG3/8"X19	29	30	17		
1JT9-05-02	U1/2"X20	ZG1/8"X28	29	27	14		
1JT9-05-04	U1/2"X20	ZG1/4"X19	29	27	14		
1JT9-05-06	U1/2"X20	ZG3/8"X19	29	30	17		
1JT9-06	U9/16"X18	ZG3/8"X19	22	22	17		
1JT9-06-04	U9/16"X18	ZG1/4"X19	29	27	14		
1JT9-06-08	U9/16"X18	ZG1/2"X14	37	37	22		
1JT9-08-04	U3/4"X16	ZG1/4"X19	33	33	19		
1JT9-08-06	U3/4"X16	ZG3/8"X19	33	33	19		
1JT9-08	U3/4"X16	ZG1/2"X14	37	37	22		
1JT9-08-12	U3/4"X16	ZG3/4"X14	40	40	27		
1JT9-10-06	U7/8"X14	ZG3/8"X19	37	37	22		
1JT9-10-08	U7/8"X14	ZG1/2"X14	37	37	22		
1JT9-10-12	U7/8"X14	ZG3/4"X14	40	40	27		
1JT9-12-08	U1.1/16"X12	ZG1/2"X14	40	40	27		
1JT9-12	U1.1/16"X12	ZG3/4"X14	40	40	27		
1JT9-12-16	U1.1/16"X12	ZG1"X11	49	49	33		
1JT9-16-12	U1.5/16"X12	ZG3/4"X14	49	49	33		
1JT9-16	U1.5/16"X12	ZG1"X11	49	49	33		
1JT9-16-20	U1.5/16"X12	ZG1.1/4"X11	57	57	44		
1JT9-16-24	U1.5/16"X12	ZG1.1/2"X11	57	57	48		
1JT9-20-16	U1.5/8"X12	ZG1"X11	57	57	44		
1JT9-20	U1.5/8"X12	ZG1.1/4"X11	57	57	44		
1JT9-20-24	U1.7/8"X12	ZG1.1/2"X11	57	57	48		
1JT9-24	U1.7/8"X12	ZG1.1/2"X11	57	57	48		
1JT9-24-20	U1.7/8"X12	ZG1.1/4"X11	57	57	48		
1JT9-32-24	U2.1/2"X12	ZG1.1/2"X11	66	66	65		
1JT9-32	U2.1/2"X12	ZG2"X11	66	66	65		

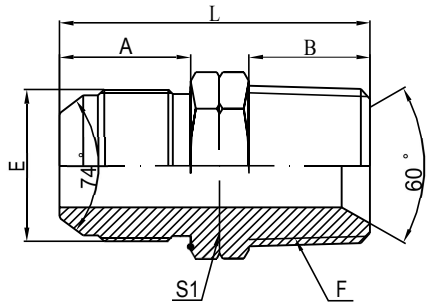

# 1JN

JIC外螺纹74°外锥/布锥管外螺纹  
JIC MALE 74° CONE/NPT MALE

代号 PART NO.	螺纹 THREADE		尺寸 DIMENSIONS				
	E	F	A	B	S1	L	
1JN-04-02	U7/16"X20	Z1/8"X27	14	10	14	30	
1JN-04	U7/16"X20	Z1/4"X18	14	14	14	34	
1JN-04-06	U7/16"X20	Z3/8"X18	14	14	19	34	
1JN-04-08	U7/16"X20	Z1/2"X14	14	19	22	41.5	
1JN-05-04	U1/2"X20	Z1/4"X18	14	14	14	34	
1JN-05-06	U1/2"X20	Z3/8"X18	14	14	19	34	
1JN-05-08	U1/2"X20	Z1/2"X14	14	19	22	41.5	
1JN-06-04	U9/16"X18	Z1/4"X18	14	14	17	34	
1JN-06	U9/16"X18	Z3/8"X18	14	14	19	34	
1JN-06-08	U9/16"X18	Z1/2"X14	14	19	22	41	
1JN-08-04	U3/4"X16	Z1/4"X18	16.7	14	22	39	
1JN-08-06	U3/4"X16	Z3/8"X18	16.7	14	22	38	
1JN-08	U3/4"X16	Z1/2"X14	16.7	19	22	44	
1JN-08-12	U3/4"X16	Z3/4"X14	16.7	19.5	30	46	
1JN-10-06	U7/8"X14	Z3/8"X18	19.5	14	24	42	
1JN-10-08	U7/8"X14	Z1/2"X14	19.5	19	24	47	
1JN-10-12	U7/8"X14	Z3/4"X14	19.5	19.5	30	48	
1JN-12-08	U1.1/16"X12	Z1/2"X14	22	19	30	50	
1JN-12	U1.1/16"X12	Z3/4"X14	22	19.5	30	50	
1JN-12-16	U1.1/16"X12	Z1"X11.5	22	24	36	57	
1JN-12-20	U1.1/16"X12	Z1.1/4"X11.5	22	25	46	60	
1JN-16-12	U1.5/16"X12	Z3/4"X14	23	19.5	36	53	
1JN-16	U1.5/16"X12	Z1"X11.5	23	24	36	58	
1JN-16-20	U1.5/16"X12	Z1.1/4"X11.5	23	25	46	61	
1JN-16-24	U1.5/16"X12	Z1.1/2"X11.5	23	25	50	64	
1JN-20-16	U1.5/8"X12	Z1"X11.5	24.5	24	46	62	
1JN-20	U1.5/8"X12	Z1.1/4"X11.5	24.5	25	46	63	
1JN-24	U1.7/8"X12	Z1.1/2"X11.5	27.5	25	50	69	
1JN-24-32	U1.7/8"X12	Z2"X11.5	27.5	29	70	74	
1JN-32	U2.1/2"X12	Z2"X11.5	34	29	70	81	

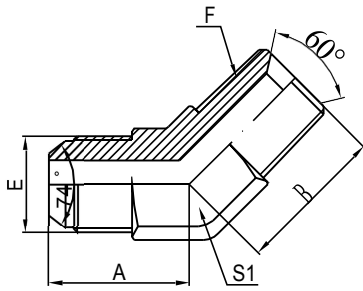

# 1JN4

45° JIC外螺纹74° 外锥/布锥管外螺纹  
45° JIC MALE 74° CONE/NPT MALE

代号 PART NO.	螺纹 THREADS		尺寸 DIMENSIONS				
	E	F	A	B	S1		
1JN4-04-02	U7/16"X20	Z1/8"X27	20	20	11		
1JN4-04	U7/16"X20	Z1/4"X18	22	22	14		
1JN4-04-06	U7/16"X20	Z3/8"X18	22	22	17		
1JN4-04-08	U7/16"X20	Z1/2"X14	27	27	22		
1JN4-05-04	U1/2"X20	Z1/4"X18	22	22	14		
1JN4-06-04	U9/16"X18	Z1/4"X18	22	22	14		
1JN4-06	U9/16"X18	Z3/8"X18	22	22	17		
1JN4-06-08	U9/16"X18	Z1/2"X14	27	27	22		
1JN4-08-04	U3/4"X16	Z1/4"X18	25	25	19		
1JN4-08-06	U3/4"X16	Z3/8"X18	25	25	19		
1JN4-08	U3/4"X16	Z1/2"X14	27	27	22		
1JN4-08-12	U3/4"X16	Z3/4"X14	33	33	27		
1JN4-10-08	U7/8"X14	Z1/2"X14	27	27	22		
1JN4-10-12	U7/8"X14	Z3/4"X14	33	33	27		
1JN4-12-08	U1.1/16"X12	Z1/2"X14	33	33	27		
1JN4-12	U1.1/16"X12	Z3/4"X14	33	33	27		
1JN4-12-16	U1.1/16"X12	Z1"X11.5	37	37	33		
1JN4-16-12	U1.5/16"X12	Z3/4"X14	37	37	33		
1JN4-16	U1.5/16"X12	Z1"X11.5	37	37	33		
1JN4-16-20	U1.5/16"X12	Z1.1/4"X11.5	40	40	44		
1JN4-20-16	U1.5/8"X12	Z1"X11.5	40	40	44		
1JN4-20	U1.5/8"X12	Z1.1/4"X11.5	40	40	44		
1JN4-20-24	U1.7/8"X12	Z1.1/2"X11.5	47	47	53		
1JN4-24	U1.7/8"X12	Z1.1/2"X11.5	47	47	53		
1JN4-32	U2.1/2"X12	Z2"X11.5	55	55	65		

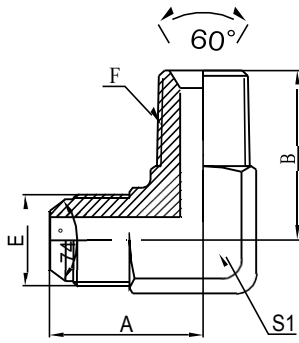

# 1JN9

90° JIC外螺纹 74° 外锥/布锥管外螺纹  
90° JIC MALE 74° CONE/NPT MALE

代号 PART NO.	螺纹 THREADS		尺寸 DIMENSIONS				
	E	F	A	B	S1		
1JN9-04-02	U7/16"X20	Z1/8"X27	22	22	11		
1JN9-04	U7/16"X20	Z1/4"X18	29	27	14		
1JN9-04-06	U7/16"X20	Z3/8"X18	29	30	17		
1JN9-05-02	U1/2"X20	Z1/8"X27	29	27	14		
1JN9-05-04	U1/2"X20	Z1/4"X18	29	27	14		
1JN9-05-06	U1/2"X20	Z3/8"X18	29	30	17		
1JN9-06	U9/16"X18	Z3/8"X18	22	22	17		
1JN9-06-04	U9/16"X18	Z1/4"X18	29	27	14		
1JN9-06-08	U9/16"X18	Z1/2"X14	37	37	22		
1JN9-08-04	U3/4"X16	Z1/4"X18	33	33	19		
1JN9-08-06	U3/4"X16	Z3/8"X18	33	33	19		
1JN9-08	U3/4"X16	Z1/2"X14	37	37	22		
1JN9-08-12	U3/4"X16	Z3/4"X14	40	40	27		
1JN9-10-06	U7/8"X14	Z3/8"X18	37	37	22		
1JN9-10-08	U7/8"X14	Z1/2"X14	37	37	22		
1JN9-10-12	U7/8"X14	Z3/4"X14	40	40	27		
1JN9-12-08	U1.1/16"X12	Z1/2"X14	40	40	27		
1JN9-12	U1.1/16"X12	Z3/4"X14	40	40	27		
1JN9-12-16	U1.1/16"X12	Z1"X11.5	49	49	33		
1JN9-16-12	U1.5/16"X12	Z3/4"X14	49	49	33		
1JN9-16	U1.5/16"X12	Z1"X11.5	49	49	33		
1JN9-16-20	U1.5/16"X12	Z1.1/4"X11.5	57	57	44		
1JN9-16-24	U1.5/16"X12	Z1.1/2"X11.5	57	57	48		
1JN9-20-16	U1.5/8"X12	Z1"X11.5	57	57	44		
1JN9-20	U1.5/8"X12	Z1.1/4"X11.5	57	57	44		
1JN9-20-24	U1.7/8"X12	Z1.1/2"X11.5	57	57	48		
1JN9-24	U1.7/8"X12	Z1.1/2"X11.5	57	57	48		
1JN9-24-20	U1.7/8"X12	Z1.1/4"X11.5	57	57	48		
1JN9-32-24	U2.1/2"X12	Z1.1/2"X11.5	66	66	65		
1JN9-32	U2.1/2"X12	Z2"X11.5	66	66	65		



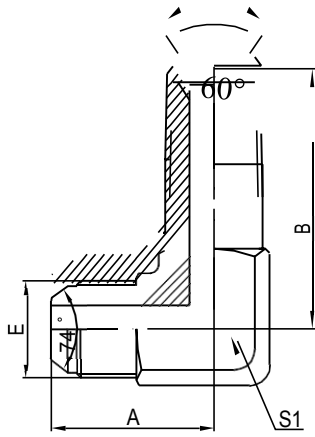

# 1JN9-L

90° JIC外螺纹74° 外锥/加长布锥管外螺纹  
90° JIC MALE 74° CONE/LONG NPT MALE

代号 PART NO.	螺纹 THREADS		尺寸 DIMENSIONS				
	E	F	A	B	S1		
1JN9-04-02L	U7/16"X20	Z1/8"X27	22	30	11		
1JN9-04L	U7/16"X20	Z1/4"X18	29	40.1	14		
1JN9-05-02L	U1/2"X20	Z1/8"X27	29	31	14		
1JN9-05-04L	U1/2"X20	Z1/4"X18	29	40.1	14		
1JN9-06-04L	U9/16"X18	Z1/4"X18	29	40.1	14		
1JN9-06-08L	U9/16"X18	Z1/2"X14	37	55.1	22		
1JN9-08-06L	U3/4"X16	Z3/8"X18	33	46.2	19		
1JN9-08L	U3/4"X16	Z1/2"X14	37	55.1	22		
1JN9-10-08L	U7/8"X14	Z1/2"X14	37	55.1	22		
1JN9-12-08L	U1.1/16"X12	Z1/2"X14	40	56.9	27		
1JN9-12L	U1.1/16"X12	Z3/4"X14	40	62	27		
1JN9-16-12L	U1.5/16"X12	Z3/4"X14	49	69.9	33		
1JN9-16L	U1.5/16"X12	Z1"X11.5	49	76.5	33		
1JN9-20L	U1.5/8"X12	Z1.1/4"X11.5	57	93.7	44		
1JN9-24L	U1.7/8"X12	Z1.1/2"X11.5	57	104.1	48		
1JN9-32L	U2.1/2"X12	Z2"X11.5	66	122.2	65		

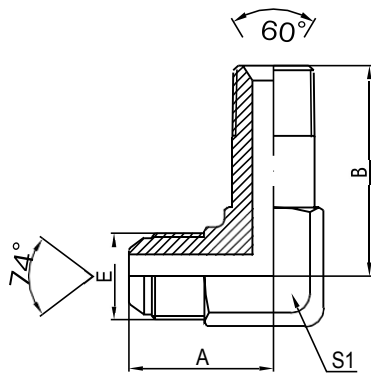

# 1JN9-LL

90° JIC外螺纹 74° 外锥/特长布锥管外螺纹  
 90° JIC MALE 74° CONE/LONGGER NPT MALE

代号 PART NO.	螺纹 THREADE		尺寸 DIMENSIONS							
	E	F				A	B	S1		
1JN9-04-02LL	U7/16"X20	Z1/8"X27				22	39.6	11		
1JN9-04LL	U7/16"X20	Z1/4"X18				29	52.6	14		
1JN9-05-04LL	U1/2"X20	Z1/4"X18				29	52.6	14		
1JN9-06-04LL	U9/16"X18	Z1/4"X18				29	52.6	14		
1JN9-06LL	U9/16"X18	Z3/8"X18				30	61.5	17		
1JN9-08-06LL	U3/4"X16	Z3/8"X18				33	61.5	19		
1JN9-10-08LL	U7/8"X14	Z1/2"X14				37	72.9	22		
1JN9-12LL	U1.1/16"X12	Z3/4"X14				40	83.3	27		
1JN9-16LL	U1.5/16"X12	Z1"X11.5				49	102.9	33		
1JN9-20LL	U1.5/8"X12	Z1.1/4"X11.5				57	127	44		
1JN9-24LL	U1.7/8"X12	Z1.1/2"X11.5				57	141	48		
1JN9-32LL	U2.1/2"X12	Z2"X11.5				66	168.4	65		

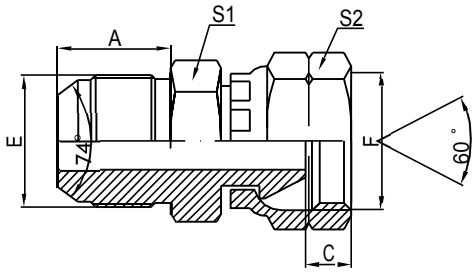

# 2JB

美制JIC外螺纹74°外锥  
 / 英管内螺纹60°外锥  
 JIC MALE 74° CONE/  
 BSP FEMALE 60° CONE

代号 PART NO.	螺纹 THREADS		尺寸 DIMENSIONS				
	E	F	A	C	S1	S2	
2JB-04	U7/16"X20	G1/4"X19	14	5.5	14	19	
2JB-04-06	U7/16"X20	G3/8"X19	14	6.5	17	22	
2JB-04-08	U7/16"X20	G1/2"X14	14	8	22	27	
2JB-06	U9/16"X18	G3/8"X19	14	6.5	17	22	
2JB-06-08	U9/16"X18	G1/2"X14	14	8	22	27	
2JB-06-10	U9/16"X18	G5/8"X14	14	10.5	22	30	
2JB-08	U3/4"X16	G1/2"X14	16.7	8	22	27	
2JB-08-06	U3/4"X16	G3/8"X19	16.7	6.5	22	22	
2JB-08-10	U3/4"X16	G5/8"X14	16.7	10.5	22	30	
2JB-10	U7/8"X16	G5/8"X14	19.5	10.5	22	30	
2JB-12	U1.1/16"X12	G3/4"X14	22	11.5	30	32	
2JB-12-08	U1.1/16"X12	G1/2"X14	22	8	30	27	
2JB-12-10	U1.1/16"X12	G5/8"X14	22	10.5	30	30	
2JB-12-16	U1.1/16"X12	G1"X11	22	11.5	32	41	
2JB-16	U1.5/16"X12	G1"X11	23	11.5	36	41	
2JB-16-20	U1.5/16"X12	G1.1/4"X11	23	12	41	50	
2JB-20	U1.5/8"X12	G1.1/4"X11	24.5	12	46	50	
2JB-20-24	U1.5/8"X12	G1.1/2"X11	24.5	13	46	55	
2JB-24	U1.7/8"X12	G1.1/2"X11	27.5	13	50	55	
2JB-32	U2.1/2"X12	G2"X11	34	16	70	70	

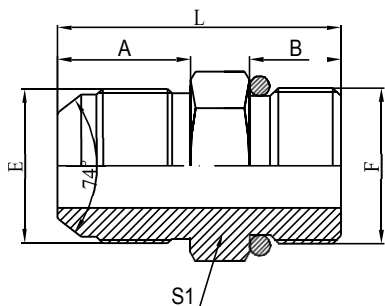

# 1JG

美制JIC外螺纹74°外锥/  
英管外螺纹O型圈  
JIC MALE 74° CONE/  
BSP MALE O-RING

代号 PART NO.	螺纹 THREADS		尺寸 DIMENSIONS				
	E	F	A	B	S1	L	
1JG-04-02	U7/16"X20	G1/8"X28	14	9	14	29	
1JG-04	U7/16"X20	G1/4"X19	14	12	19	33	
1JG-04-06	U7/16"X20	G3/8"X19	14	13.5	22	35	
1JG-04-08	U7/16"X20	G1/2"X14	14	16	27	39	
1JG-05-04	U1/2"X20	G1/4"X19	14	12	19	33	
1JG-05-06	U1/2"X20	G3/8"X19	14	13.5	22	35	
1JG-05-08	U1/2"X20	G1/2"X14	14	16	27	39	
1JG-06-04	U9/16"X18	G1/4"X19	14	12	19	32	
1JG-06	U9/16"X18	G3/8"X19	14	13.5	22	35	
1JG-06-08	U9/16"X18	G1/2"X14	14	16	27	39	
1JG-08-04	U3/4"X16	G1/4"X19	16.7	12	22	37	
1JG-08-06	U3/4"X16	G3/8"X19	16.7	13.5	22	38.5	
1JG-08	U3/4"X16	G1/2"X14	16.7	16	27	41	
1JG-08-12	U3/4"X16	G3/4"X14	16.7	18.5	32	46	
1JG-10-06	U7/8"X14	G3/8"X19	19.5	13.5	24	42	
1JG-10-08	U7/8"X14	G1/2"X14	19.5	16	27	45	
1JG-10-12	U7/8"X14	G3/4"X14	19.5	18.5	32	49	
1JG-12-08	U1.1/16"X12	G1/2"X14	22	16	30	47	
1JG-12	U1.1/16"X12	G3/4"X14	22	18.5	32	51	
1JG-12-16	U1.1/16"X12	G1"X11	22	20.5	19	54	
1JG-12-20	U1.1/16"X12	G1.1/4"X11	22	20.5	50	56	
1JG-16-12	U1.5/16"X12	G3/4"X14	23	18.5	36	52	
1JG-16	U1.5/16"X12	G1"X11	23	20.5	41	55	
1JG-16-20	U1.5/16"X12	G1.1/4"X11	23	20.5	50	57	
1JG-20-16	U1.5/8"X12	G1"X11	24.5	20.5	46	58	
1JG-20	U1.5/8"X12	G1.1/4"X11	24.5	20.5	50	58	
1JG-24-16	U1.7/8"X12	G1"X11	27.5	20.5	50	61	
1JG-24-20	U1.7/8"X12	G1.1/4"X11	27.5	20.5	50	61	
1JG-24	U1.7/8"X12	G1.1/2"X11	27.5	23	55	67	

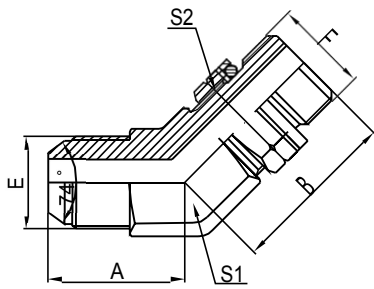

# 1JG4-OG

45° 美制JIC外螺纹74° 外锥/  
 英管外螺纹O型圈45°  
 JIC MALE 74° CONE/ BSP  
 MALE O-RING

代号 PART NO.	螺纹 THREADS		尺寸 DIMENSIONS				
	E	F	A	B	S1	S2	
1JG4-04OG	U7/16"X20	G1/4"X19	22	28	14	19	
1JG4-05-04OG	U1/2"X20	G1/4"X19	22	28	14	19	
1JG4-06-04OG	U9/16"X18	G1/4"X19	22	28	17	19	
1JG4-06OG	U9/16"X18	G3/8"X19	22	32	17	22	
1JG4-08-06OG	U3/4"X16	G3/8"X19	25	32	19	22	
1JG4-08OG	U3/4"X16	G1/2"X14	27	36	22	27	
1JG4-10-08OG	U7/8"X14	G1/2"X14	27	38	22	27	
1JG4-10OG	U7/8"X14	G5/8"X14	27	38	22	30	
1JG4-12-10OG	U1.1/16"X12	G5/8"X14	33	38.5	27	30	
1JG4-12-16OG	U1.1/16"X12	G1"X11	37	44	33	41	
1JG4-12OG	U1.1/16"X12	G3/4"X14	33	42	27	32	
1JG4-16-12OG	U1.5/16"X12	G3/4"X14	37	44	33	32	
1JG4-16OG	U1.5/16"X12	G1"X11	37	44	33	41	
1JG4-20OG	U1.5/8"X12	G1.1/4"X11	40	47.5	44	50	
1JG4-24OG	U1.7/8"X12	G1.1/2"X11	47	51.5	53	55	

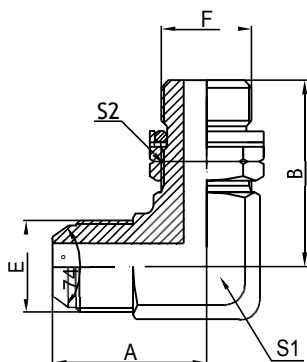

# 1JG9-OG

90° 美制JIC外螺纹74° 外锥/  
 英管外螺纹O型圈90°  
 JIC MALE 74° CONE/ BSP  
 MALE O-RING

代号 PART NO.	螺纹 THREADE		尺寸 DIMENSIONS				
	E	F	A	B	S1	S2	
1JG9-04-02OG	U7/16"X20	G1/8"X28	22	26.2	11	14	
1JG9-04-06OG	U7/16"X20	G3/8"X19	30	36.8	17	22	
1JG9-04OG	U7/16"X20	G1/4"X19	29	31.3	14	19	
1JG9-05-04OG	U1/2"X20	G1/4"X19	29	31.8	14	19	
1JG9-05-06OG	U1/2"X20	G3/8"X19	30	35.8	17	22	
1JG9-05-08OG	U1/2"X20	G1/2"X14	37	43.2	22	27	
1JG9-06-04OG	U9/16"X18	G1/4"X19	29	31.3	14	19	
1JG9-06-08OG	U9/16"X18	G1/2"X14	37	43.2	22	27	
1JG9-06OG	U9/16"X18	G3/8"X19	30	35.8	17	22	
1JG9-08-04OG	U3/4"X16	G1/4"X19	33	33.5	19	19	
1JG9-08-06OG	U3/4"X16	G3/8"X19	33	36.8	19	22	
1JG9-08OG	U3/4"X16	G1/2"X14	37	43.2	22	27	
1JG9-08-12OG	U3/4"X16	G3/4"X14	40	49.3	27	32	
1JG9-10-06OG	U7/8"X16	G3/8"X19	37	39.2	22	22	
1JG9-10-08OG	U7/8"X16	G1/2"X14	37	43.2	22	27	
1JG9-10-12OG	U7/8"X16	G3/4"X14	40	49.3	27	32	
1JG9-12OG	U1.1/16"X12	G3/4"X14	40	49.3	27	32	
1JG9-12-08OG	U1.1/16"X12	G1/2"X14	40	46.5	27	27	
1JG9-12-16OG	U1.1/16"X12	G1"X11	49	53	33	41	
1JG9-16OG	U1.5/16"X12	G1"X11	49	53	33	41	
1JG9-16-12OG	U1.5/16"X12	G3/4"X14	49	53	33	32	
1JG9-16-20OG	U1.5/16"X12	G1.1/4"X11	57	58	44	50	
1JG9-20OG	U1.5/8"X12	G1.1/4"X11	57	58	44	50	
1JG9-20-16OG	U1.5/8"X12	G1"X11	57	58	44	41	
1JG9-24-16OG	U1.7/8"X12	G1"X11	57	63	48	41	
1JG9-24-20OG	U1.7/8"X12	G1.1/4"X11	57	63	48	50	
1JG9-24OG	U1.7/8"X12	G1.1/2"X11	57	63	48	55	

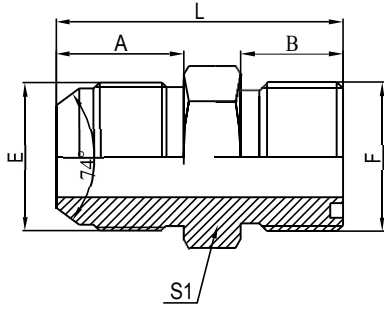

# 1JF

美制JIC外螺纹74°外锥/ORFS外螺纹  
JIC MALE 74° CONE/ORFS MALE

代号 PART NO.	螺纹 THREADE		尺寸 DIMENSIONS				
	E	F	A	B	S1	L	
1JF-04	U7/16"X20	U9/16"X18	14	12	17	32	
1JF-05-04	U1/2"X20	U9/16"X18	14	12	17	32	
1JF-05-06	U1/2"X20	U11/16"X16	14	14	19	34	
1JF-06-04	U9/16"X18	U9/16"X18	14	12	17	32	
1JF-08-06	U3/4"X16	U11/16"X16	16.7	14	19	37	
1JF-08	U3/4"X16	U13/16"X16	16.7	15	22	40	
1JF-10-08	U7/8"X16	U13/16"X16	19.5	15	24	43	
1JF-10	U7/8"X16	U1"X14	19.5	16.5	27	46	
1JF-12-10	U1.1/16"X12	U1"X14	22	16.5	30	49	
1JF-12	U1.1/16"X12	U1.3/16"X12	22	17	32	50	
1JF-16-12	U1.5/16"X12	U1.3/16"X12	23	17	36	51	
1JF-16	U1.5/16"X12	U1.7/16"X12	23	18.5	41	54	
1JF-20-16	U1.5/8"X12	U1.7/16"X12	24.5	18.5	46	56	
1JF-20	U1.5/8"X12	U1.11/16"X12	24.5	19.5	46	57	
1JF-24-20	U1.7/8"X12	U1.11/16"X12	27.5	19.5	50	64	

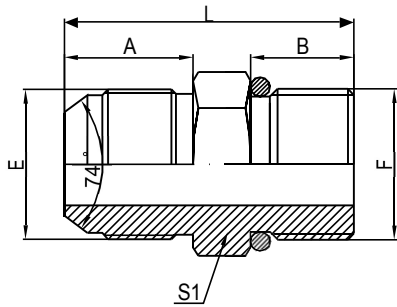

# 1JH

JIC外螺纹74°外锥/  
公制外螺纹O型圈密封  
JIC MALE 74° CONE/  
METRIC MALE END O-RING

代号 PART NO.	螺纹 THREADE		尺寸 DIMENSIONS				
	E	F	A	B	S1	L	
1JH-04-10	U7/16"X20	M10x1	14	11	14	31	
1JH-04-12	U7/16"X20	M12x1.5	14	11	17	31	
1JH-04-14	U7/16"X20	M14x1.5	14	11	19	32	
1JH-05-10	U1/2"X20	M10x1	14	11	14	31	
1JH-05-12	U1/2"X20	M12x1.5	14	11	17	31	
1JH-05-14	U1/2"X20	M14x1.5	14	11	19	31	
1JH-06-14	U9/16"X18	M14x1.5	14	11	19	32	
1JH-06-16	U9/16"X18	M16x1.5	14	11	22	33	
1JH-06-18	U9/16"X18	M18x1.5	14	11	24	33	
1JH-08-14	U3/4"X16	M14x1.5	16.7	11	22	36	
1JH-08-16	U3/4"X16	M16x1.5	16.7	11	22	36	
1JH-08-18	U3/4"X16	M18x1.5	16.7	11	24	36	
1JH-08-22	U3/4"X16	M22x1.5	16.7	12	27	37	
1JH-10-16	U7/8"X14	M16x1.5	13.5	11	24	33	
1JH-10-18	U7/8"X14	M18x1.5	13.5	11	24	33	
1JH-10-22	U7/8"X14	M22x1.5	13.5	12	27	33	
1JH-12-22	U1.1/16"X12	M22x1.5	16	12	30	38	
1JH-12-27	U1.1/16"X12	M27x2	16	13	32	39	
1JH-16-27	U1.5/16"X12	M27x2	16	13	36	40	



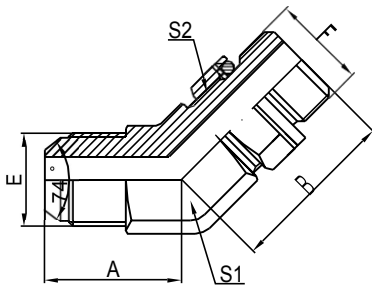

# 1JH4-OG

45° 美制JIC外螺纹74° 外锥/  
公制外螺纹可调向柱端  
45° JIC MALE 74° CONE/METRIC MALE  
ADJUSTABLE STUD END

代号 PART NO.	螺纹 THREADE		尺寸 DIMENSIONS				
	E	F	A	B	S1	S2	
1JH4-04-10OG	U7/16"X20	M10x1	20	23.5	11	14	
1JH4-04-12OG	U7/16"X20	M12x1.5	22	27.5	14	17	
1JH4-04-14OG	U7/16"X20	M14x1.5	22	28.3	14	19	
1JH4-05-12OG	U1/2"X20	M12x1.5	22	28.3	14	17	
1JH4-05-14OG	U1/2"X20	M14x1.5	22	28.3	14	19	
1JH4-06-14OG	U9/16"X18	M14x1.5	22	28.3	14	19	
1JH4-06-16OG	U9/16"X18	M16x1.5	22	29	17	22	
1JH4-08-16OG	U3/4"X16	M16x1.5	25	30	19	22	
1JH4-08-18OG	U3/4"X16	M18x1.5	25	31	19	24	
1JH4-10-16OG	U7/8"X14	M16x1.5	27	31	22	22	
1JH4-10-18OG	U7/8"X14	M18x1.5	27	32	22	24	
1JH4-10-22OG	U7/8"X14	M22x1.5	33	33	27	27	
1JH4-12-22OG	U1.1/16"X12	M22x1.5	33	34.5	27	27	
1JH4-12-27OG	U1.1/16"X12	M27x2	33	39.5	27	32	
1JH4-16-27OG	U1.5/16"X12	M27x2	37	41	33	32	

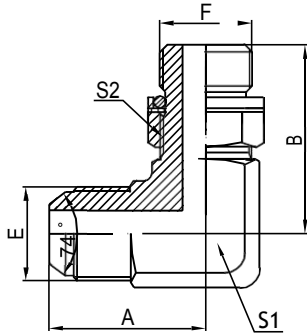

# 1JH9-OG

90° 美制JIC外螺纹74° 外锥/  
公制外螺纹可调向柱端  
90° JIC MALE 74° CONE/METRIC MALE  
ADJUSTABLE STUD END

代号 PART NO.	螺纹 THREADE		尺寸 DIMENSIONS				
	E	F	A	B	S1	S2	
1JH9-04-10OG	U7/16"X20	M10x1	22	27.5	11	14	
1JH9-04-12OG	U7/16"X20	M12x1.5	29	30.3	14	17	
1JH9-04-14OG	U7/16"X20	M14x1.5	29	32	14	19	
1JH9-05-12OG	U1/2"X20	M12x1.5	29	32	14	17	
1JH9-05-14OG	U1/2"X20	M14x1.5	29	32	14	19	
1JH9-06-14OG	U9/16"X18	M14x1.5	29	32	14	19	
1JH9-06-16OG	U9/16"X18	M16x1.5	30	34.8	17	22	
1JH9-08-16OG	U3/4"X16	M16x1.5	33	38	19	22	
1JH9-08-18OG	U3/4"X16	M18x1.5	33	38	19	24	
1JH9-10-16OG	U7/8"X14	M16x1.5	37	38	22	22	
1JH9-10-18OG	U7/8"X14	M18x1.5	37	39.5	22	24	
1JH9-10-22OG	U7/8"X14	M22x1.5	40	42.5	27	27	
1JH9-12-22OG	U1.1/16"X12	M22x1.5	40	44	27	27	
1JH9-12-27OG	U1.1/16"X12	M27x2	40	48.5	27	32	
1JH9-16-27OG	U1.5/16"X12	M27x2	49	41	33	32	

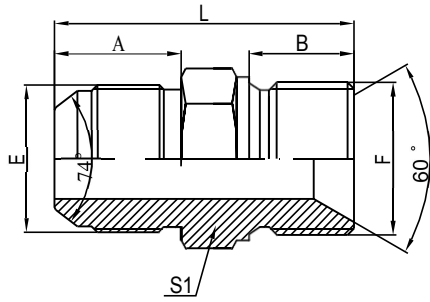

# 1JM

JIC外螺纹74°外锥/公制外螺纹  
 60°内锥或六角端面组合垫密封  
 JIC MALE 74° CONE/METRIC MALE DOUBLE  
 USE FOR 60° SEAT OR BONDED SEAL

代号 PART NO.	螺纹 THREADS		尺寸 DIMENSIONS				
	E	F	A	B	S1	L	
1JM-04-12	U7/16"X20	M12x1.5	14	10	17	32	
1JM-04-14	U7/16"X20	M14x1.5	14	11	19	33	
1JM-05-12	U1/2"X20	M12x1.5	14	10	17	32	
1JM-05-14	U1/2"X20	M14x1.5	14	11	19	33	
1JM-06-12	U9/16"X18	M12x1.5	14	10	17	32	
1JM-06-14	U9/16"X18	M14x1.5	14	11	19	33	
1JM-06-16	U9/16"X18	M16x1.5	14	12	22	35	
1JM-06-18	U9/16"X18	M18x1.5	14	12	24	50	
1JM-08-16	U3/4"X16	M16x1.5	16.7	12	22	38	
1JM-08-18	U3/4"X16	M18x1.5	16.7	12	24	38	
1JM-08-22	U3/4"X16	M22x1.5	16.7	14	27	41	
1JM-10-22	U7/8"X16	M22x1.5	19.5	14	27	44	
1JM-12-22	U1.1/16"X12	M22x1.5	22	14	30	48	

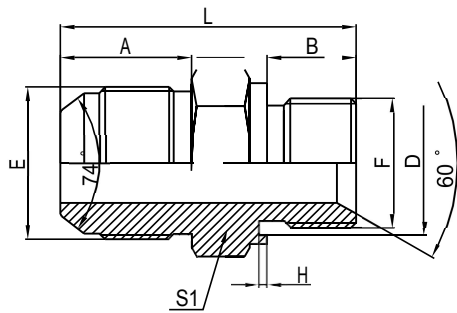

# 1JM-WD

JIC外螺纹74°外锥/  
公制外螺纹胶垫密封  
JIC MALE 74° CONE/  
METRIC MALE CAPTIVE SEAL

代号 PART NO.	螺纹 THREADE		尺寸 DIMENSIONS							
	E	F			A	B	D	H	S1	L
1JM-04-12WD	U7/16"X20	M12x1.5			14	10	14.2	1.2	17	32
1JM-05-14WD	U1/2"X20	M14x1.5			14	11	16.3	1.2	19	33
1JM-06-14WD	U9/16"X18	M14x1.5			14	11	16.3	1.2	19	33
1JM-06-18WD	U9/16"X18	M18x1.5			14	12	20.7	1.2	24	36.5
1JM-08-18WD	U3/4"X16	M18x1.5			16.7	12	20.7	1.2	24	39
1JM-08-22WD	U3/4"X16	M22x1.5			16.7	14	24.1	1.2	27	43.5
1JM-10-18WD	U7/8"X16	M18x1.5			19.5	12	20.7	1.2	24	41.5
1JM-10-22WD	U7/8"X16	M22x1.5			19.5	14	24.1	1.2	27	46
1JM-12-22WD	U1.1/16"X12	M22x1.5			22	14	24.1	1.2	30	49

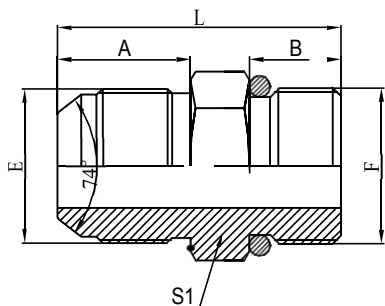

# 1JO

美制JIC外螺纹74°外锥/  
SAE外螺纹带O型圈  
JIC MALE 74° CONE/  
SAE O-RING BOSS

代号 PART NO.	螺纹 THREADS		尺寸 DIMENSIONS				
	E	F	A	B	S1	L	
1JO-04	U7/16"X20	U7/16"X20	14	10	14	31	
1JO-04-05	U7/16"X20	U1/2"X20	14	10	17	30	
1JO-04-06	U7/16"X20	U9/16"X18	14	12	17	32	
1JO-04-08	U7/16"X20	U3/4"X16	14	12	24	35	
1JO-05	U1/2"X20	U1/2"X20	14	10	17	30	
1JO-05-04	U1/2"X20	U7/16"X20	14	10	14	30	
1JO-05-06	U1/2"X20	U9/16"X18	14	12	17	32	
1JO-05-08	U1/2"X20	U3/4"X16	14	12	24	35	
1JO-06	U9/16"X18	U9/16"X18	14	12	17	33	
1JO-06-04	U9/16"X18	U7/16"X20	14	10	17	31	
1JO-06-05	U9/16"X18	U1/2"X20	14	10	17	30	
1JO-06-08	U9/16"X18	U3/4"X16	14	12	24	35	
1JO-06-10	U9/16"X18	U7/8"X14	14	13.5	27	36	
1JO-06-12	U9/16"X18	U1.1/16"X12	14	16	32	39	
1JO-08	U3/4"X16	U3/4"X16	16.7	12	24	37	
1JO-08-04	U3/4"X16	U7/16"X20	16.7	10	22	35	
1JO-08-06	U3/4"X16	U9/16"X18	16.7	12	22	37	
1JO-08-10	U3/4"X16	U7/8"X14	16.7	13.5	27	39	
1JO-08-12	U3/4"X16	U1.1/16"X12	16.7	16	32	42	
1JO-10	U7/8"X14	U7/8"X14	19.5	13.5	27	41.5	
1JO-10-08	U7/8"X14	U3/4"X16	19.5	12	24	40	
1JO-10-12	U7/8"X14	U1.1/16"X12	19.5	16	32	45	
1JO-12	U1.1/16"X12	U1.1/16"X12	22	16	32	47	
1JO-12-08	U1.1/16"X12	U3/4"X16	22	12	30	43	
1JO-12-10	U1.1/16"X12	U7/8"X14	22	13.5	30	45	
1JO-12-16	U1.1/16"X12	U1.5/16"X12	22	17	41	50	
1JO-16	U1.5/16"X12	U1.5/16"X12	23	17	41	51	
1JO-16-12	U1.5/16"X12	U1.1/16"X12	23	16	36	50	
1JO-16-20	U1.5/16"X12	U1.5/8"X12	23	18	50	55	
1JO-20	U1.5/8"X12	U1.5/8"X12	24.5	18	50	56	

接上页

代号 PART NO.	螺纹 THREADE		尺寸 DIMENSIONS				
	E	F	A	B	S1	L	
1JO-16-20	U1.5/16"X12	U1.5/8"X12	23	18	50	55	
1JO-20-16	U1.5/8"X12	U1.5/16"X12	24.5	17	46	55	
1JO-20-24	U1.5/8"X12	U1.7/8"X12	24.5	18.5	55	59	
1JO-24	U1.7/8"X12	U1.7/8"X12	27.5	18.5	55	62	
1JO-24-20	U1.7/8"X12	U1.5/8"X12	27.5	18	50	59	
1JO-24-32	U1.7/8"X12	U2.1/2"X12	27.5	22	70	67.5	
1JO-32	U2.1/2"X12	U2.1/2"X12	34	22	70	74	

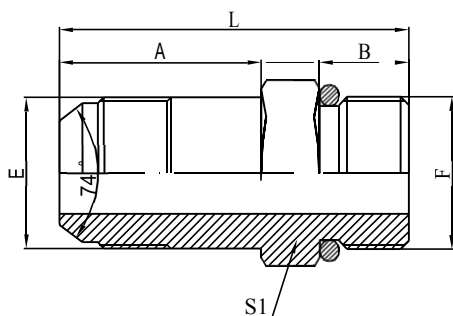

## 1JO-L

加长美制JIC外螺纹74°外锥/  
SAE外螺纹带O型圈  
LONG JIC MALE 74° CONE/  
SAE O-RING BOSS

代号 PART NO.	螺纹 THREADE		尺寸 DIMENSIONS				
	E	F	A	B	S1	L	
1JO-04L	U7/16"X20	U7/16"X20	35	10	14	51	
1JO-05L	U1/2"X20	U1/2"X20	37	10	17	53	
1JO-06L	U9/16"X18	U9/16"X18	39	12	17	57	
1JO-08L	U3/4"X16	U3/4"X16	48	12	24	69	
1JO-10L	U7/8"X14	U7/8"X14	53	13.5	27	75	
1JO-12L	U1.1/16"X12	U1.1/16"X12	63	16	32	88	
1JO-16L	U1.5/16"X12	U1.5/16"X12	72	17	41	100	
1JO-20L	U1.5/8"X12	U1.5/8"X12	88.1	18	50	120	

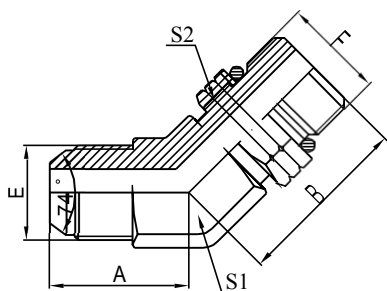

# 1J04-OG

45° JIC外螺纹74° 外锥/  
SAE外螺纹带O型圈  
45° JIC MALE 74° CONE/  
SAE O-RING BOSS

代号 PART NO.	螺纹 THREADS		尺寸 DIMENSIONS				
	E	F	A	B	S1	S2	
1J04-04OG	U7/16"X20	U7/16"X20	20	24	11	17	
1J04-04-06OG	U7/16"X20	U9/16"X18	22	27.5	14	19	
1J04-04-08OG	U7/16"X20	U3/4"X16	25	32.5	19	24	
1J04-05OG	U1/2"X20	U1/2"X20	22	26.7	14	17	
1J04-05-04OG	U1/2"X20	U7/16"X20	22	26.7	14	17	
1J04-06OG	U9/16"X18	U9/16"X18	22	28	14	19	
1J04-06-04OG	U9/16"X18	U7/16"X20	22	26	14	17	
1J04-06-05OG	U9/16"X18	U1/2"X20	22	26	14	17	
1J04-06-08OG	U9/16"X18	U3/4"X16	25	32.5	19	24	
1J04-06-10OG	U9/16"X18	U7/8"X14	27	38.5	22	27	
1J04-08OG	U3/4"X16	U3/4"X16	25	32.5	19	24	
1J04-08-06OG	U3/4"X16	U9/16"X18	25	28	19	19	
1J04-08-10OG	U3/4"X16	U7/8"X14	27	38.7	22	27	
1J04-08-12OG	U3/4"X16	U1.1/16"X12	33	43.9	27	32	
1J04-10OG	U7/8"X14	U7/8"X14	27	38.7	22	27	
1J04-10-08OG	U7/8"X14	U3/4"X16	27	33	22	27	
1J04-10-12OG	U7/8"X14	U1.1/16"X12	33	43.9	27	32	
1J04-12OG	U1.1/16"X12	U1.1/16"X12	33	43.5	27	32	
1J04-12-10OG	U1.1/16"X12	U7/8"X14	33	42	27	27	
1J04-12-16OG	U1.1/16"X12	U1.5/16"X12	37	45.5	33	41	
1J04-16OG	U1.5/16"X12	U1.5/16"X12	37	45.5	33	41	
1J04-16-12OG	U1.5/16"X12	U1.1/16"X12	37	45	33	32	
1J04-16-20OG	U1.5/16"X12	U1.5/8"X12	40	47	44	50	
1J04-20OG	U1.5/8"X12	U1.5/8"X12	40	48.5	44	50	
1J04-20-24OG	U1.5/8"X12	U1.7/8"X12	47	50	53	55	
1J04-24OG	U1.7/8"X12	U1.7/8"X12	47	50	53	55	
1J04-32OG	U1.7/8"X12	U2.1/2"X12	55	54	65	70	

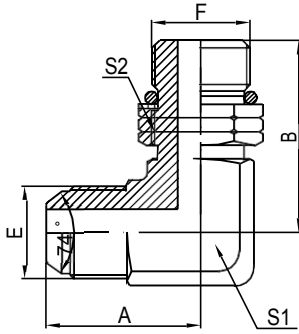

# 1JO9-OG

90° JIC外螺纹74° 外锥/  
SAE外螺纹带O型圈  
90° JIC MALE 74° CONE/  
SAE O-RING BOSS

代号 PART NO.	螺纹 THREADS		尺寸 DIMENSIONS				
	E	F	A	B	S1	S2	
1JO9-04OG	U7/16"X20	U7/16"X20	22	27.2	11	17	
1JO9-04-06OG	U7/16"X20	U9/16"X18	29	31.8	14	19	
1JO9-05-04OG	U1/2"X20	U7/16"X20	29	30	14	17	
1JO9-05OG	U1/2"X20	U1/2"X20	29	29	14	17	
1JO9-05-06OG	U1/2"X20	U9/16"X18	29	31.8	14	19	
1JO9-06OG	U9/16"X18	U9/16"X18	29	31.8	14	19	
1JO9-06-04OG	U9/16"X18	U7/16"X20	29	30	14	17	
1JO9-06-05OG	U9/16"X18	U1/2"X20	29	29.9	14	17	
1JO9-06-08OG	U9/16"X18	U3/4"X16	33	36.8	19	24	
1JO9-08-04OG	U3/4"X16	U7/16"X20	33	33	19	17	
1JO9-08OG	U3/4"X16	U3/4"X16	33	36.8	19	24	
1JO9-08-06OG	U3/4"X16	U9/16"X18	33	33.5	19	19	
1JO9-08-10OG	U3/4"X16	U7/8"X14	37	44	22	27	
1JO9-08-12OG	U3/4"X16	U1.1/16"X12	40	51	27	32	
1JO9-10OG	U7/8"X14	U7/8"X14	37	44	22	27	
1JO9-10-08OG	U7/8"X14	U3/4"X16	37	40	22	27	
1JO9-10-12OG	U7/8"X14	U1.1/16"X12	40	51	27	32	
1JO9-12OG	U1.1/16"X12	U1.1/16"X12	40	51	27	32	
1JO9-12-10OG	U1.1/16"X12	U7/8"X14	40	47	27	27	
1JO9-12-16OG	U1.1/16"X12	U1.5/16"X12	49	54.5	33	41	
1JO9-16OG	U1.5/16"X12	U1.5/16"X12	49	54.5	33	41	
1JO9-16-12OG	U1.5/16"X12	U1.1/16"X12	49	54.5	33	32	
1JO9-16-20OG	U1.5/16"X12	U1.5/8"X12	57	59	44	50	
1JO9-20OG	U1.5/8"X12	U1.5/8"X12	57	59	44	50	
1JO9-20-24OG	U1.5/8"X12	U1.7/8"X12	57	63	48	55	
1JO9-24OG	U1.7/8"X12	U1.7/8"X12	57	63	48	55	
1JO9-32OG	U1.7/8"X12	U2.1/2"X12	66	76	65	70	



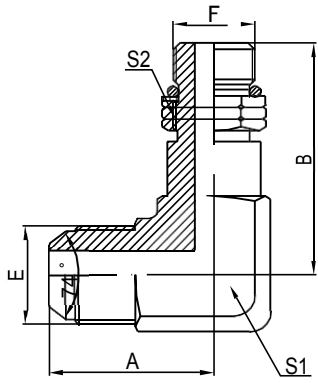

# 1J09-OG / L

90° 美制JIC外螺纹74° 外锥/  
 加长SAE外螺纹带O型圈90°  
 JIC MALE 74° CONE/ LONG  
 SAE O-RING BOSS

代号 PART NO.	螺纹 THREADE		尺寸 DIMENSIONS				
	E	F	A	B	S1	S2	
1J09-040G/ L	U7/16"X20	U7/16"X20	22	44	11	17	
1J09-060G/ L	U9/16"X18	U9/16"X18	29	52.8	14	19	
1J09-080G/ L	U3/4"X16	U3/4"X16	33	63.5	19	24	
1J09-100G/ L	U7/8"X14	U7/8"X14	37	73.4	22	27	
1J09-120G/ L	U1.1/16"X12	U1.1/16"X12	40	84.8	27	32	
1J09-160G/ L	U1.5/16"X12	U1.5/16"X12	49	94.5	33	41	

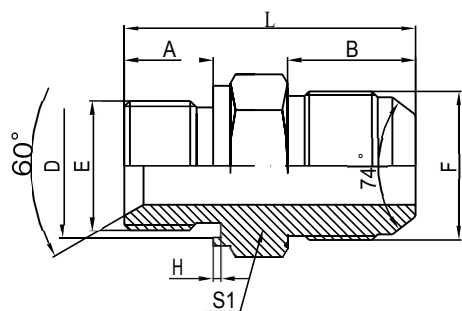

# 1BJ-WD

英管外螺纹胶垫密封/JIC外螺纹74°外锥  
BSP MALE CAPTIVE SEAL/JIC MALE 74° CONE

代号 PART NO.	螺纹 THREADE		尺寸 DIMENSIONS							
	E	F			A	B	D	H	S1	L
1BJ-02-04WD	G1/8"X28	U7/16"X20			10	14	11.7	0.7	14	31.5
1BJ-04WD	G1/4"X19	U7/16"X20			12	14	16.3	1.2	19	34
1BJ-06-04WD	G3/8"X19	U7/16"X20			13.5	14	18.7	1.2	22	36
1BJ-08-04WD	G1/2"X14	U7/16"X20			16	14	23.7	1.2	27	43
1BJ-04-05WD	G1/4"X19	U1/2"X20			12	14	16.3	1.2	19	34
1BJ-06-05WD	G3/8"X19	U1/2"X20			13.5	14	18.7	1.2	22	36
1BJ-02-06WD	G1/8"X28	U9/16"X18			10	14	11.7	0.7	17	31.5
1BJ-04-06WD	G1/4"X19	U9/16"X18			12	14	16.3	1.2	19	34
1BJ-06WD	G3/8"X19	U9/16"X18			13.5	14	18.7	1.2	22	36
1BJ-08-06WD	G1/2"X14	U9/16"X18			16	14	23.7	1.2	27	43
1BJ-04-08WD	G1/4"X19	U3/4"X16			12	16.7	16.3	1.2	22	37
1BJ-06-08WD	G3/8"X19	U3/4"X16			13.5	16.7	18.7	1.2	22	39
1BJ-08WD	G1/2"X14	U3/4"X16			16	16.7	23.7	1.2	27	45.5
1BJ-08-10WD	G1/2"X14	U7/8"X16			16	19.5	23.7	1.2	27	49
1BJ-12-10WD	G3/4"X14	U7/8"X16			18.5	19.5	29	1.2	32	50
1BJ-08-12WD	G1/2"X14	U1.1/16"X12			16	22	23.7	1.2	30	50.5
1BJ-12WD	G3/4"X14	U1.1/16"X12			18.5	22	29	1.2	32	52.5
1BJ-16-12WD	G1"X11	U1.1/16"X12			20.5	22	35.5	1.6	41	58.5
1BJ-12-16WD	G3/4"X14	U1.5/16"X12			18.5	23	29	1.2	36	55.5
1BJ-16WD	G1"X11	U1.5/16"X12			20.5	23	35.5	1.6	41	59.5
1BJ-20-16WD	G1.1/4"X11	U1.5/16"X12			20.5	23	45.6	1.6	50	61.5
1BJ-16-20WD	G1"X11	U1.5/8"X12			20.5	24.5	35.5	1.6	46	61
1BJ-20WD	G1.1/4"X11	U1.5/8"X12			20.5	24.5	45.6	1.6	50	63
1BJ-24-20WD	G1.1/2"X11	U1.5/8"X12			23	24.5	50.5	1.6	55	65
1BJ-20-24WD	G1.1/4"X11	U1.7/8"X12			20.5	27.5	45.6	1.6	50	66
1BJ-24WD	G1.1/2"X11	U1.7/8"X12			23	27.5	50.5	1.6	55	68.5

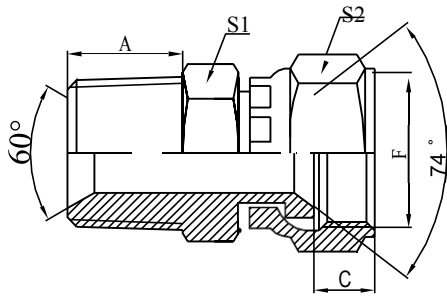

# 2TJ

英锥管外螺纹/JIC内螺纹74°内锥  
BSPT MALE/JIC FEMALE 74° SEAT

代号 PART NO.	螺纹 THREADE		尺寸 DIMENSIONS				
	E	F	A	C	S1	S2	
2TJ-02-04	ZG1/8"X28	U7/16"X20	10	8.5	14	17	
2TJ-04	ZG1/4"X19	U7/16"X20	14	8.5	17	17	
2TJ-04-05	ZG1/4"X19	U1/2"X20	14	9.5	17	19	
2TJ-04-06	ZG1/4"X19	U9/16"X18	14	10	17	19	
2TJ-06-05	ZG3/8"X19	U1/2"X20	14	9.5	17	19	
2TJ-06	ZG3/8"X19	U9/16"X18	14	10	17	19	
2TJ-06-08	ZG3/8"X19	U3/4"X16	14	11	19	24	
2TJ-08	ZG1/2"X14	U3/4"X16	19	11	22	24	
2TJ-08-10	ZG1/2"X14	U7/8"X14	19	11	22	27	
2TJ-08-12	ZG1/2"X14	U1.1/16"X12	19	13.5	27	32	
2TJ-12	ZG3/4"X14	U1.1/16"X12	19.5	13.5	30	32	
2TJ-12-16	ZG3/4"X14	U1.5/16"X12	19.5	14.5	36	41	
2TJ-16	ZG1"X11	U1.5/16"X12	24	14.5	36	41	
2TJ-20	ZG1.1/4"X11	U1.5/8"X12	24	15.5	46	50	
2TJ-24	ZG1.1/2"X11	U1.7/8"X12	25	18.5	50	55	

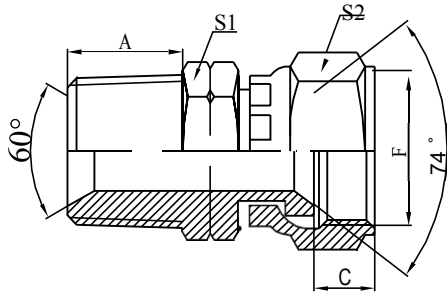

# 2NJ

布锥管外螺纹/JIC内螺纹74°内锥  
NPT MALE/JIC FEMALE 74° SEAT

代号 PART NO.	螺纹 THREADS		尺寸 DIMENSIONS				
	E	F	A	C	S1	S2	
2NJ-02-04	Z1/8"X27	U7/16"X20	10	8.5	14	17	
2NJ-02-05	Z1/8"X27	U1/2"X20	10	9.5	14	19	
2NJ-04	Z1/4"X18	U7/16"X20	14	8.5	17	17	
2NJ-04-05	Z1/4"X18	U1/2"X20	14	9.5	17	19	
2NJ-04-06	Z1/4"X18	U9/16"X18	14	10	17	19	
2NJ-04-08	Z1/4"X18	U3/4"X16	14	11	19	24	
2NJ-06	Z3/8"X18	U9/16"X18	14	10	17	19	
2NJ-06-08	Z3/8"X18	U3/4"X16	14	11	19	24	
2NJ-06-10	Z3/8"X18	U7/8"X14	14	11	22	27	
2NJ-08	Z1/2"X14	U3/4"X16	19	11	22	24	
2NJ-08-06	Z1/2"X14	U9/16"X18	19	10	22	19	
2NJ-08-10	Z1/2"X14	U7/8"X14	19	11	22	27	
2NJ-08-12	Z1/2"X14	U1.1/16"X12	19	13.5	27	32	
2NJ-12	Z3/4"X14	U1.1/16"X12	19.5	13.5	30	32	
2NJ-12-08	Z3/4"X14	U3/4"X16	19.5	11	27	24	
2NJ-12-10	Z3/4"X14	U7/8"X14	19.5	11	27	27	
2NJ-12-16	Z3/4"X14	U1.5/16"X12	19.5	14.5	36	41	
2NJ-16	Z1"X11.5	U1.5/16"X12	24	14.5	36	41	
2NJ-16-12	Z1"X11.5	U1.1/16"X12	24	13.5	36	32	
2NJ-16-20	Z1"X11.5	U1.5/8"X12	24	15.5	46	50	
2NJ-20	Z1.1/4"X11.5	U1.5/8"X12	24	15.5	46	50	
2NJ-20-24	Z1.1/4"X11.5	U1.7/8"X12	24	18.5	46	55	
2NJ-24-20	Z1.1/2"X11.5	U1.5/8"X12	25	15.5	50	50	
2NJ-24	Z1.1/2"X11.5	U1.7/8"X12	25	18.5	50	55	

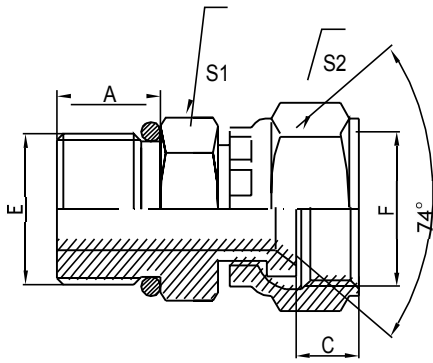

# 2GJ

英管外螺纹O型圈/JIC内螺纹74°锥面  
BSP MALE O-RING/JIC FEMALE 74° CONE

代号 PART NO.	螺纹 THREADE		尺寸 DIMENSIONS				
	E	F	A	C	S1	S2	
2GJ-04	G1/4"X19	U7/16"X20	12	8.5	19	17	
2GJ-04-05	G1/4"X19	U1/2"X20	12	9.5	19	19	
2GJ-04-06	G1/4"X19	U9/16"X18	12	10	19	19	
2GJ-06	G3/8"X19	U9/16"X18	13.5	10	22	19	
2GJ-06-08	G3/8"X19	U3/4"X16	13.5	11	22	24	
2GJ-08	G1/2"X14	U3/4"X16	16	11	27	24	
2GJ-08-06	G1/2"X14	U9/16"X18	16	10	27	19	
2GJ-08-10	G1/2"X14	U7/8"X16	16	11	27	27	
2GJ-12	G3/4"X14	U1.1/16"X12	18.5	13.5	32	32	
2GJ-12-08	G3/4"X14	U3/4"X16	18.5	11	32	24	
2GJ-12-10	G3/4"X14	U7/8"X16	18.5	11	32	27	
2GJ-12-16	G3/4"X14	U1.5/16"X12	18.5	14.5	32	41	
2GJ-16	G1"X11	U1.5/16"X12	20.5	14.5	41	41	
2GJ-20	G1.1/4"X11	U1.5/8"X12	20.5	15.5	50	50	
2GJ-24	G1.1/2"X11	U1.7/8"X12	23	18.5	55	55	

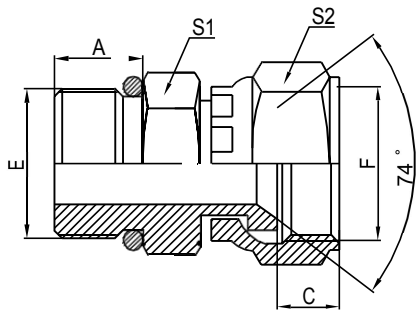

## 20J

美制SAE外螺纹带O型圈/  
JIC内螺纹74°内锥  
SAE O-RING BOSS/  
JIC FEMALE 74° SEAT

代号 PART NO.	螺纹 THREADE		尺寸 DIMENSIONS				
	E	F	A	C	S1	S2	
20J-04	U7 / 16"X20	U7 / 16"X20	10	8.5	14	17	
20J-05	U1 / 2"X20	U1 / 2"X20	10	9.5	17	19	
20J-06	U9 / 16"X18	U9 / 16"X18	12	10	17	19	
20J-08	U3 / 4"X16	U3 / 4"X16	12	11	22	24	
20J-10	U7 / 8"X14	U7 / 8"X14	13.5	11	27	27	
20J-12	U1.1 / 16"X12	U1.1 / 16"X12	16	13.5	32	32	
20J-16	U1.5 / 16"X12	U1.5 / 16"X12	17	14.5	41	41	
20J-20	U1.5 / 8"X12	U1.5 / 8"X12	18	15.5	50	50	

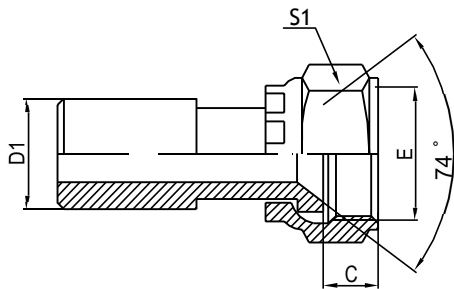

## 2WJ

焊接管/美制JIC内螺纹74°内锥  
BUTT-WELD TUBE/JIC FEMALE 74° SEAT

代号 PART NO.	螺纹 THREADE		管子直径 TUBE O.D. D1	尺寸 DIMENSIONS			
	E			C	S1		
2WJ-10-04	U7 / 16"X20		10	8.5	17		
2WJ-12-05	U1 / 2"X20		12	9.5	19		
2WJ-14-04	U7 / 16"X20		14	8.5	17		
2WJ-14-06	U9 / 16"X18		14	10	19		
2WJ-18-08	U3 / 4"X16		18	11	24		
2WJ-20-10	U7 / 8"X14		20	11	27		
2WJ-22-12	U1.1 / 16"X12		22	13.5	32		
2WJ-28-16	U1.5 / 16"X12		28	14.5	41		
2WJ-34-20	U1.5 / 8"X12		34	15.5	50		

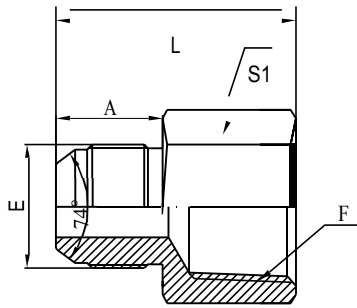

# 5JB

美制JIC外螺纹74°外锥/英管内螺纹  
JIC MALE 74° CONE/BSP FEMALE

代号 PART NO.	螺纹 THREADE		尺寸 DIMENSIONS				
	E	F	A	S1	L		
5JB-04	U7/16"X20	G1/4"X19	14	19	32		
5JB-04-02	U7/16"X20	G1/8"X28	14	14	29		
5JB-04-06	U7/16"X20	G3/8"X19	14	22	34		
5JB-06	U9/16"X18	G3/8"X19	14	22	34		
5JB-06-08	U9/16"X18	G1/2"X14	14	27	34		
5JB-08	U3/4"X16	G1/2"X14	16.7	27	37		
5JB-08-10	U3/4"X16	G5/8"X14	16.7	30	43		
5JB-10-12	U7/8"X16	G3/4"X14	19.5	32	44		
5JB-12	U1.1/16"X12	G3/4"X14	22	36	52		
5JB-12-16	U1.1/16"X12	G1"X11	22	41	56		
5JB-16	U1.5/16"X12	G1"X11	23	41	57		
5JB-16-20	U1.5/16"X12	G1.1/4"X11	23	50	59		
5JB-20	U1.5/8"X12	G1.1/4"X11	24.5	50	61		
5JB-24	U1.7/8"X12	G1.1/2"X11	27.5	55	65		
5JB-32	U2.1/2"X12	G2"X11	34	70	71		

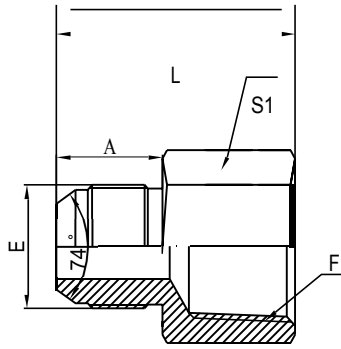

# 5JT

美制JIC外螺纹74°外锥/英锥管内螺纹  
JIC MALE 74° CONE/BSPT FEMALE

代号 PART NO.	螺纹 THREADE		尺寸 DIMENSIONS						
	E	F				A	S1	L	
5JT-04-02	U7/16"X20	ZG1/8"X28				14	17	29	
5JT-04	U7/16"X20	ZG1/4"X19				14	19	32	
5JT-06-04	U9/16"X18	ZG1/4"X19				14	19	32	
5JT-06	U9/16"X18	ZG3/8"X19				14	22	34	
5JT-08-06	U3/4"X16	ZG3/8"X19				16.7	22	37	
5JT-08	U3/4"X16	ZG1/2"X14				16.7	30	43	
5JT-10-08	U7/8"X14	ZG1/2"X14				19.5	30	36	
5JT-12	U1.1/16"X12	ZG3/4"X14				22	36	52	
5JT-16	U1.5/16"X12	ZG1"X11				23	41	57	



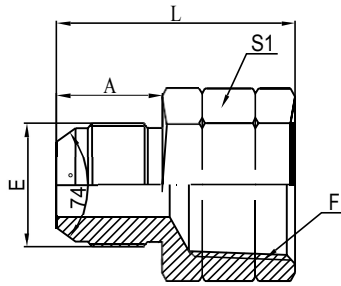

# 5JN

美制JIC外螺纹74°外锥/布锥管内螺纹  
JIC MALE 74° CONE/NPT FEMALE

代号 PART NO.	螺纹 THREADE		尺寸 DIMENSIONS				
	E	F		A	S1	L	
5JN-04-02	U7/16"X20	Z1/8"X27		14	17	29	
5JN-04	U7/16"X20	Z1/4"X18		14	19	32	
5JN-05-04	U1/2"X20	Z1/4"X18		14	19	32	
5JN-06-04	U9/16"X18	Z1/4"X18		14	19	32	
5JN-06	U9/16"X18	Z3/8"X18		14	22	34	
5JN-06-08	U9/16"X18	Z1/2"X14		14	30	40	
5JN-08-06	U3/4"X16	Z3/8"X18		16.7	22	37	
5JN-08	U3/4"X16	Z1/2"X14		16.7	30	43	
5JN-08-12	U3/4"X16	Z3/4"X14		16.7	36	47	
5JN-10-08	U7/8"X14	Z1/2"X14		19.5	30	46	
5JN-10-12	U7/8"X14	Z3/4"X14		19.5	36	50	
5JN-12-08	U1.1/16"X12	Z1/2"X14		22	30	48	
5JN-12	U1.1/16"X12	Z3/4"X14		22	36	52	
5JN-16-12	U1.5/16"X12	Z3/4"X14		23	36	53	
5JN-16	U1.5/16"X12	Z1"X11.5		23	41	57	
5JN-20	U1.5/8"X12	Z1.1/4"X11.5		24.5	50	61	
5JN-24	U1.7/8"X12	Z1.1/2"X11.5		27.5	60	65	
5JN-32	U2.1/2"X12	Z2"X11.5		34	70	71	

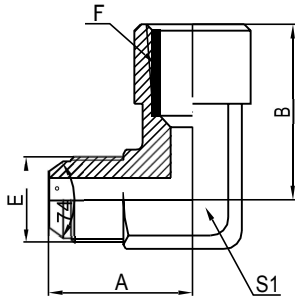

# 5JN9

90° 美制JIC外螺纹74° 外锥/布锥管内螺纹  
 90° JIC MALE 74° CONE/NPT FEMALE

代号 PART NO.	螺纹 THREADE		尺寸 DIMENSIONS				
	E	F	A	B	S1		
5JN9-04-02	U7/16"X20	Z1/8"X27	27	21	17		
5JN9-04	U7/16"X20	Z1/4"X18	27	21	17		
5JN9-06-04	U9/16"X18	Z1/4"X18	32	27	22		
5JN9-06	U9/16"X18	Z3/8"X18	32	27	22		
5JN9-08-04	U3/4"X16	Z1/4"X18	35	30	27		
5JN9-08	U3/4"X16	Z1/2"X14	35	30	27		
5JN9-12-08	U1.1/16"X12	Z1/2"X14	35	30	27		
5JN9-12	U1.1/16"X12	Z3/4"X14	40	32	33		
5JN9-12-16	U1.1/16"X12	Z1"X11.5	38	49	41		
5JN9-16-12	U1.5/16"X12	Z3/4"X14	49	38	41		
5JN9-16	U1.5/16"X12	Z1"X11.5	49	38	41		

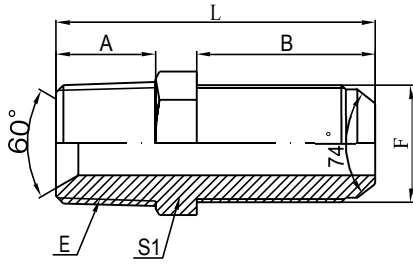

# 6NJ

美制NPT外螺纹/美制JIC外螺纹外锥过板接头  
NPT MALE/JIC MALE 74° CONE BULKHEAD

代号 PART NO.	螺纹 THREADS		尺寸 DIMENSIONS				
	E	F	A	B	S1	L	
6NJ-02-04	Z1/8"X27	U7/16"X20	10	32.5	14	48.5	
6NJ-04	Z1/4"X18	U7/16"X20	14	32.5	14	52.5	
6NJ-04-06	Z1/4"X18	U9/16"X18	14	32.5	17	52.5	
6NJ-06	Z3/8"X18	U9/16"X18	14	32.5	17	52.5	
6NJ-08	Z1/2"X14	U3/4"X16	19	36.5	22	64	
6NJ-08-10	Z1/2"X14	U7/8"X14	19	40	22	67	
6NJ-12	Z3/4"X14	U1.1/16"X12	19.5	44.5	27	73	
6NJ-16	Z1"X11.5	U1.5/16"X12	24	44.5	36	79.5	
6NJ-20	Z1.1/4"X11.5	U1.5/8"X12	25	45.7	46	84	
6NJ-24	Z1.1/2"X11.5	U1.7/8"X12	25	46	50	88	

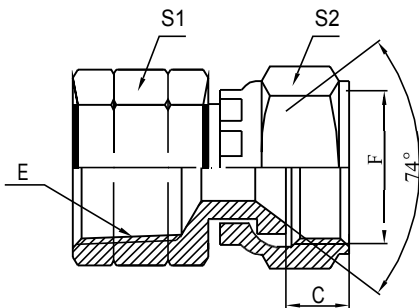

# 7NJ

布锥管内螺纹/JIC内螺纹74°内锥  
NPT FEMALE/JIC FEMALE 74° SEAT

代号 PART NO.	螺纹 THREADS		尺寸 DIMENSIONS			
	E	F	C	S1	S2	
7NJ-04	Z1/4"X18	U7/16"X20	8.5	19	17	
7NJ-04-06	Z1/4"X18	U9/16"X18	10	19	19	
7NJ-06	Z3/8"X18	U9/16"X18	10	24	19	
7NJ-06-08	Z3/8"X18	U3/4"X16	11	24	24	
7NJ-08	Z1/2"X14	U3/4"X16	11	30	24	
7NJ-08-10	Z1/2"X14	U7/8"X14	11	30	27	
7NJ-08-12	Z1/2"X14	U1.1/16"X12	13.5	30	32	
7NJ-12	Z3/4"X14	U1.1/16"X12	13.5	36	32	
7NJ-16	Z1"X11.5	U1.5/16"X12	14.5	41	41	
7NJ-20	Z1.1/4"X11.5	U1.5/8"X12	15.5	50	50	
7NJ-24	Z1.1/2"X11.5	U1.7/8"X12	18.5	60	55	

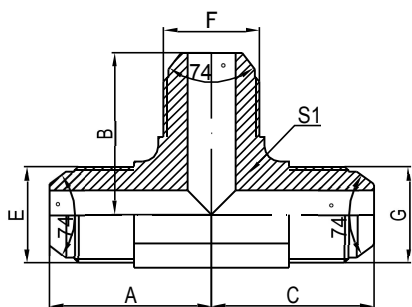

# AJ

美制JIC外螺纹74°外锥三通  
JIC MALE 74° CONE TEE

代号 PART NO.	螺纹 THREADE			尺寸 DIMENSIONS				
	E	F	G	A	B	C	S1	
AJ-04	U7 / 16"X20	U7/16"X20	U7/16"X20	24	24	24	11	
AJ-04-06-04	U7 / 16"X20	U9/16"X18	U7/16"X20	27	27	27	14	
AJ-05	U1 / 2"X20	U1/2"X20	U1/2"X20	27	27	27	14	
AJ-06-04-06	U9 / 16"X18	U7/16"X20	U9/16"X18	27	27	27	14	
AJ-06	U9 / 16"X18	U9/16"X18	U9/16"X18	27	27	27	14	
AJ-08	U3 / 4"X16	U3/4"X16	U3/4"X16	30	30	30	19	
AJ-08-06-08	U3 / 4"X16	U9/16"X18	U3/4"X16	30	30	30	19	
AJ-10	U7 / 8"X14	U7/8"X14	U7 / 8"X14	33	33	33	22	
AJ-12	U1.1 / 16"X12	U1.1 / 16"X12	U1.1 / 16"X12	40	40	40	27	
AJ-16	U1.5 / 16"X12	U1.5 / 16"X12	U1.5 / 16"X12	49	49	49	33	
AJ-16-12-16	U1.5 / 16"X12	U1.1 / 16"X12	U1.5 / 16"X12	49	49	49	33	
AJ-20	U1.5 / 8"X12	U1.5 / 8"X12	U1.5 / 8"X12	57	57	57	44	

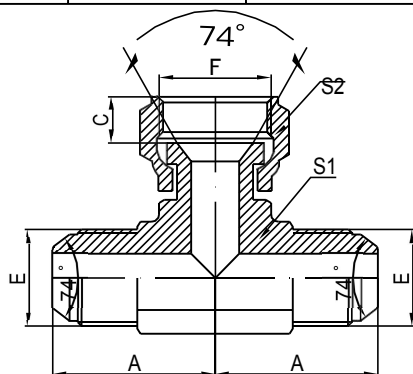

# BJ

美制JIC外螺纹74°外锥/  
美制JIC内螺纹74°内锥分支三通  
JIC MALE 74° CONE/  
JIC FEMALE BRANCH TEE

代号 PART NO.	螺纹 THREADE			尺寸 DIMENSIONS				
	E	F		A	C	S1	S2	
BJ-04	U7/16"X20	U7/16"X20		24	8.5	11	17	
BJ-05	U1/2"X20	U1/2"X20		27	9.5	14	19	
BJ-06	U9/16"X18	U9/16"X18		27	10	14	19	
BJ-08	U3/4"X16	U3/4"X16		30	11	19	24	
BJ-10	U7/8"X14	U7/8"X14		33	11	22	27	
BJ-12	U1.1/16"X12	U1.1/16"X12		40	13.5	27	32	
BJ-16	U1.5/16"X12	U1.5/16"X12		49	14.5	33	41	
BJ-20	U1.5/8"X12	U1.5/8"X12		57	15.5	44	50	

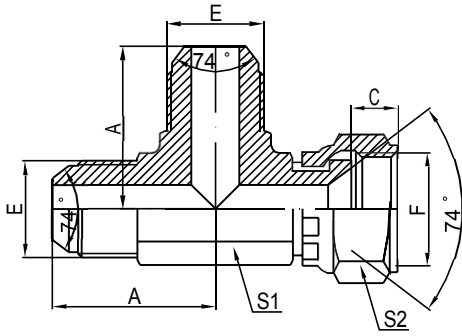

# CJ

美制JIC外螺纹74°外锥/  
美制JIC内螺纹74°内锥主支三通  
JIC MALE 74° CONE/  
JIC FEMALE 74° SEAT RUN TEE

代号 PART NO.	螺纹 THREADE		尺寸 DIMENSIONS				
	E	F	A	C	S1	S2	
CJ-04	U7/16"X20	U7/16"X20	24	8.5	11	17	
CJ-05	U1/2"X20	U1/2"X20	27	9.5	14	19	
CJ-06	U9/16"X18	U9/16"X18	27	10	14	19	
CJ-08	U3/4"X16	U3/4"X16	30	11	19	24	
CJ-10	U7/8"X14	U7/8"X14	33	11	22	27	
CJ-12	U1.1/16"X12	U1.1/16"X12	40	13.5	27	32	
CJ-16	U1.5/16"X12	U1.5/16"X12	49	14.5	33	41	
CJ-20	U1.5/8"X12	U1.5/8"X12	57	15.5	44	50	

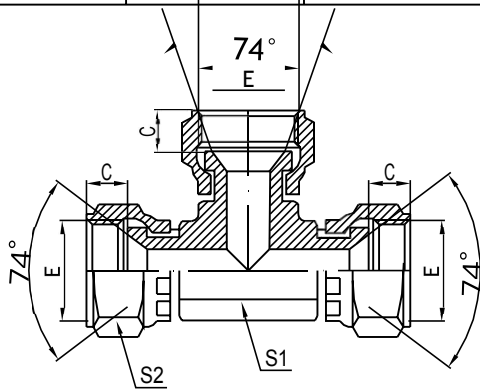

# DJ

美制JIC内螺纹74°内锥三通  
JIC FEMALE 74° SEAT TEE

代号 PART NO.	螺纹 THREADE		尺寸 DIMENSIONS			
	E	F	C	S1	S2	
DJ-04	U7/16"X20	U7/16"X20	8.5	11	17	
DJ-05	U1/2"X20	U1/2"X20	9.5	11	19	
DJ-06	U9/16"X18	U9/16"X18	10	14	19	
DJ-08	U3/4"X16	U3/4"X16	11	19	24	
DJ-10	U7/8"X14	U7/8"X14	11	22	27	
DJ-12	U1.1/16"X12	U1.1/16"X12	13.5	27	32	
DJ-16	U1.5/16"X12	U1.5/16"X12	14.5	33	41	
DJ-20	U1.5/8"X12	U1.5/8"X12	15.5	44	50	

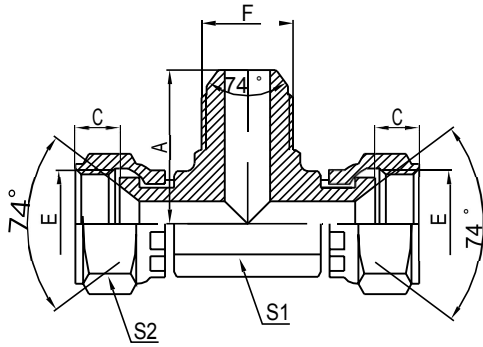

# EJ

美制JIC内螺纹74°内锥/  
美制JIC外螺纹74°外锥分支三通  
JIC FEMALE 74° SEAT/  
JIC MALE 74° CONE BRANCH TEE

代号 PART NO.	螺纹 THREADE		尺寸 DIMENSIONS				
	E	F	A	C	S1	S2	
EJ-04	U7/16"X20	U7/16"X20	24	8.5	11	17	
EJ-05	U1/2"X20	U1/2"X20	27	9.5	14	19	
EJ-06	U9/16"X18	U9/16"X18	27	10	14	19	
EJ-08	U3/4"X16	U3/4"X16	30	11	19	24	
EJ-10	U7/8"X14	U7/8"X14	33	11	22	27	
EJ-12	U1.1/16"X12	U1.1/16"X12	40	13.5	27	32	
EJ-16	U1.5/16"X12	U1.5/16"X12	49	14.5	33	41	
EJ-20	U1.5/8"X12	U1.5/8"X12	57	15.5	44	50	

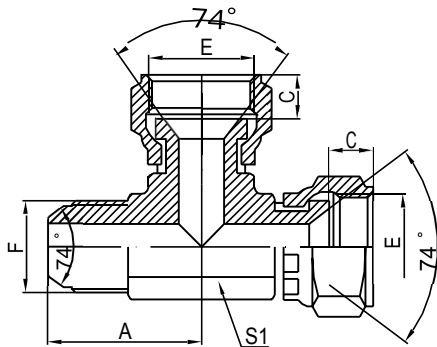

# FJ

美制JIC内螺纹74°内锥/  
美制JIC外螺纹74°外锥分支三通  
JIC FEMALE 74° SEAT/  
JIC MALE 74° CONE BRANCH TEE

代号 PART NO.	螺纹 THREADE		尺寸 DIMENSIONS				
	E	F	A	C	S1	S2	
EJ-04	U7/16"X20	U7/16"X20	24	8.5	11	17	
EJ-05	U1/2"X20	U1/2"X20	27	9.5	14	19	
EJ-06	U9/16"X18	U9/16"X18	27	10	14	19	
EJ-08	U3/4"X16	U3/4"X16	30	11	19	24	
EJ-10	U7/8"X14	U7/8"X14	33	11	22	27	
EJ-12	U1.1/16"X12	U1.1/16"X12	40	13.5	27	32	
EJ-16	U1.5/16"X12	U1.5/16"X12	49	14.5	33	41	
EJ-20	U1.5/8"X12	U1.5/8"X12	57	15.5	44	50	

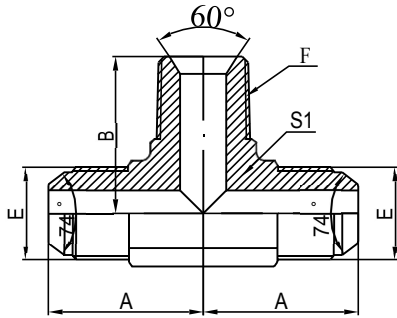

# AJNJ

美制JIC外螺纹74°外锥/  
 布锥管外螺纹分支三通  
 JIC MALE 74° CONE/  
 NPT MALE BRANCH TEE

代号 PART NO.	螺纹 THREADS		尺寸 DIMENSIONS				
	E	F	A	B	S1		
AJNJ-04	U7/16"X20	Z1/4"X18	27	27	14		
AJNJ-04-02-04	U7/16"X20	Z1/8"X27	24	24	11		
AJNJ-05-02-05	U1/2"X20	Z1/8"X27	27	27	14		
AJNJ-05-04-05	U1/2"X20	Z1/4"X18	27	27	14		
AJNJ-06	U9/16"X18	Z3/8"X18	28	28	17		
AJNJ-06-04-06	U9/16"X18	Z1/4"X18	27	27	14		
AJNJ-08	U3/4"X16	Z1/2"X14	33	33	22		
AJNJ-08-06-08	U3/4"X16	Z3/8"X18	30	30	19		
AJNJ-10-08-10	U7/8"X14	Z1/2"X14	33	33	22		
AJNJ-10-12-10	U7/8"X14	Z3/4"X14	40	40	27		
AJNJ-12	U1.1/16"X12	Z3/4"X14	40	40	27		
AJNJ-16	U1.5/16"X12	Z1"X11.5	49	49	33		
AJNJ-20	U1.5/8"X12	Z1.1/4"X11.5	57	57	44		

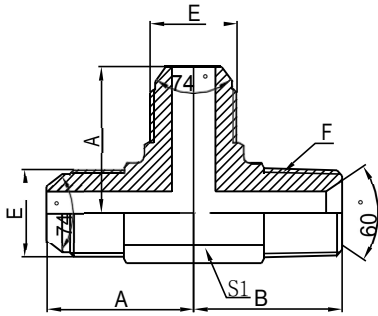

# AJJN

美制JIC外螺纹74°外锥/  
布锥管外螺纹主支三通  
JIC MALE 74° CONE/  
NPT MALE RUN TEE

代号 PART NO.	螺纹 THREADE		尺寸 DIMENSIONS				
	E	F	A	B	S1		
AJJN-04	U7/16"X20	Z1/4"X18	27	27	14		
AJJN-04-04-02	U7/16"X20	Z1/8"X27	24	24	11		
AJJN-05-05-02	U1/2"X20	Z1/8"X27	27	27	14		
AJJN-05-05-04	U1/2"X20	Z1/4"X18	27	27	14		
AJJN-06	U9/16"X18	Z3/8"X18	28	28	17		
AJJN-06-06-04	U9/16"X18	Z1/4"X18	27	27	14		
AJJN-08	U3/4"X16	Z1/2"X14	33	33	22		
AJJN-08-08-06	U3/4"X16	Z3/8"X18	30	30	19		
AJJN-10-10-08	U7/8"X14	Z1/2"X14	33	33	22		
AJJN-10-10-12	U7/8"X14	Z3/4"X14	40	40	27		
AJJN-12	U1.1/16"X12	Z3/4"X14	40	40	27		
AJJN-16	U1.5/16"X12	Z1"X11.5	49	49	33		
AJJN-20	U1.5/8"X12	Z1.1/4"X11.5	57	57	44		



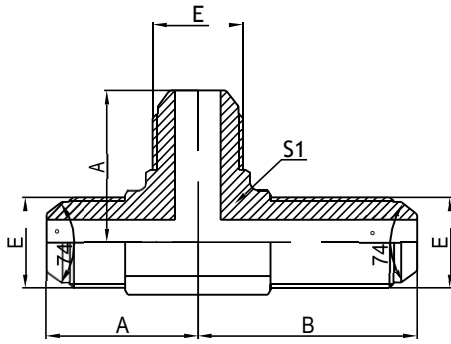

# AJJ6J

美制JIC外螺纹74°外锥过板接头主支三通  
JIC MALE 74° CONE BULKHEAD RUN TEE

代号 PART NO.	螺纹 THREADE				尺寸 DIMENSIONS				
	E				A	B	S1		
AJJ6J-04	U7/16"X20				24	40.4	11		
AJJ6J-06	U9/16"X18				27	46	14		
AJJ6J-08	U3/4"X16				30	53.5	19		
AJJ6J-10	U7/8"X14				33	60.7	22		
AJJ6J-12	U1.1/16"X12				40	67.8	27		
AJJ6J-16	U1.5/16"X12				49	71	33		
AJJ6J-20	U1.5/8"X12				57	79.2	44		

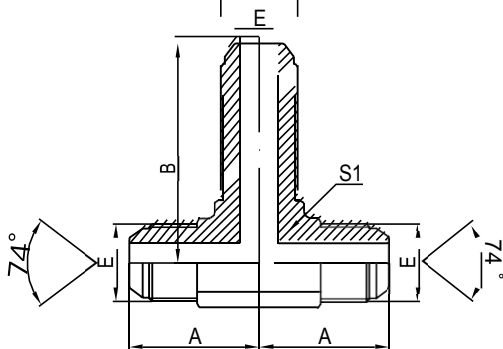

# AJ6JJ

美制JIC外螺纹74°外锥过板接头分支三通  
JIC MALE 74° CONE BULKHEAD BRANCH TEE

代号 PART NO.	螺纹 THREADE				尺寸 DIMENSIONS				
	E				A	B	S1		
AJ6JJ-04	U7/16"X20				24	40.4	11		
AJ6JJ-06	U9/16"X18				27	46	14		
AJ6JJ-08	U3/4"X16				30	53.5	19		
AJ6JJ-10	U7/8"X14				33	60.7	22		
AJ6JJ-12	U1.1/16"X12				40	67.8	27		
AJ6JJ-16	U1.5/16"X12				49	71	33		

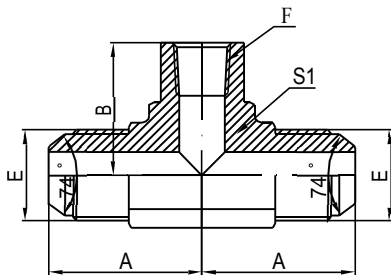

# KJNJ

美制JIC外螺纹74°外锥/  
布锥管内螺纹分支三通  
JIC MALE 74° CONE/  
NPT FEMALE BRANCH TEE

代号 PART NO.	螺纹 THREADS		尺寸 DIMENSIONS				
	E	F	A	B	S1		
KJNJ-04	U7/16"X20	Z1/4"X18	30	22.4	19		
KJNJ-04-02-04	U7/16"X20	Z1/8"X27	28	16.8	17		
KJNJ-05-02-05	U1/2"X20	Z1/8"X27	28	16.8	17		
KJNJ-05-04-05	U1/2"X20	Z1/4"X18	30	22.4	19		
KJNJ-06	U9/16"X18	Z3/8"X18	33	25.9	22		
KJNJ-06-04-06	U9/16"X18	Z1/4"X18	30	22.4	19		
KJNJ-08	U3/4"X16	Z1/2"X14	40	31.2	27		
KJNJ-08-06-08	U3/4"X16	Z3/8"X18	40	25.9	27		
KJNJ-10-08-10	U7/8"X14	Z1/2"X14	40	31.2	27		
KJNJ-12	U1.1/16"X12	Z3/4"X14	49	34.5	33		
KJNJ-16	U1.5/16"X12	Z1"X11.5	57	41.1	44		

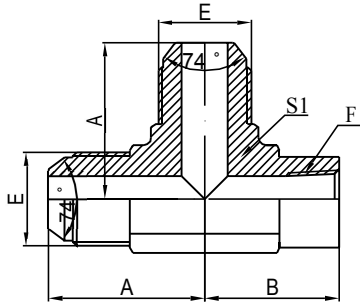

# LJJN

美制JIC外螺纹74°外锥/  
 布锥管内螺纹主支三通  
 JIC MALE 74° CONE/  
 NPT FEMALE RUN TEE

代号 PART NO.	螺纹 THREADE		尺寸 DIMENSIONS				
	E	F	A	B	S1		
LJJN-04	U7/16"X20	Z1/4"X18	30	25.1	19		
LJJN-04-04-02	U7/16"X20	Z1/8"X27	28	16.8	17		
LJJN-06	U9/16"X18	Z3/8"X18	33	26.8	22		
LJJN-06-06-04	U9/16"X18	Z1/4"X18	30	22.5	19		
LJJN-08	U3/4"X16	Z1/2"X14	40	33	27		
LJJN-08-08-06	U3/4"X16	Z3/8"X18	40	25.9	27		
LJJN-10-10-08	U7/8"X14	Z1/2"X14	40	31.2	27		
LJJN-12	U1.1/16"X12	Z3/4"X14	49	39	33		
LJJN-16	U1.5/16"X12	Z1"X11.5	57	43.9	27		
LJJN-20	U1.5/8"X12	Z1.1/4"X11.5	57	43.3	44		

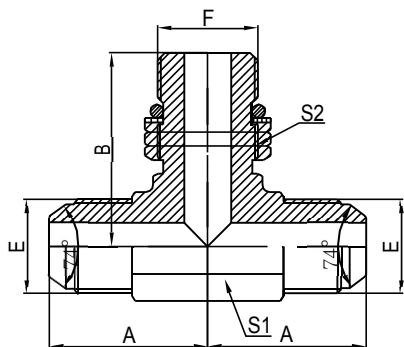

# AJOJ-OG

美制JIC外螺纹74°外锥/  
SAE外螺纹带O型圈分支三通  
JIC MALE 74° CONE/  
SAE O-RING BOSS BRANCH TEE

代号 PART NO.	螺纹 THREADS		尺寸 DIMENSIONS				
	E	F	A	B	S1	S2	
AJOJ-04OG	U7/16"X20	U7/16"X20	24	27.2	11	17	
AJOJ-05OG	U1/2"X20	U1/2"X20	27	29	14	17	
AJOJ-05-04-05OG	U1/2"X20	U7/16"X20	27	30	14	17	
AJOJ-06OG	U9/16"X18	U9/16"X18	27	31.8	14	19	
AJOJ-06-04-06OG	U9/16"X18	U7/16"X20	27	30	14	17	
AJOJ-06-05-06OG	U9/16"X18	U1/2"X20	27	30	14	17	
AJOJ-08OG	U3/4"X16	U3/4"X16	30	36.8	19	24	
AJOJ-08-06-08OG	U3/4"X16	U9/16"X18	30	33.5	19	19	
AJOJ-10OG	U7/8"X14	U7/8"X14	33	44	22	27	
AJOJ-10-08-10OG	U7/8"X14	U3/4"X16	33	40	22	24	
AJOJ-12OG	U1.1/16"X12	U1.1/16"X12	33	51	24	32	
AJOJ-12-08-12OG	U1.1/16"X12	U3/4"X16	33	44	24	24	
AJOJ-12-10-12OG	U1.1/16"X12	U7/8"X14	33	49	24	27	
AJOJ-16OG	U1.5/16"X12	U1.5/16"X12	49	54.5	33	41	
AJOJ-20-16-20OG	U1.5/8"X12	U1.5/16"X12	57	59.5	44	41	
AJOJ-20OG	U1.5/8"X12	U1.5/8"X12	57	59	44	50	

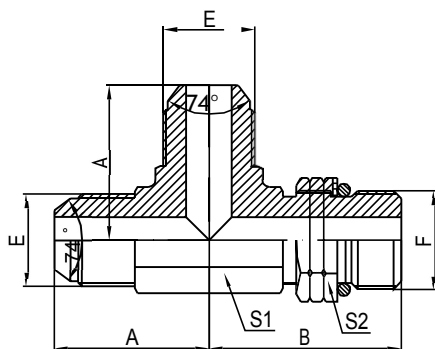

# AJJO-OG

美制JIC外螺纹74°外锥/  
SAE外螺纹带O型圈主支三通  
JIC MALE 74° CONE/  
SAE O-RING BOSS RUN TEE

代号 PART NO.	螺纹 THREADS		尺寸 DIMENSIONS				
	E	F	A	B	S1	S2	
AJJO-04OG	U7/16"X20	U7/16"X20	24	27.2	11	17	
AJJO-05OG	U1/2"X20	U1/2"X20	27	29	14	17	
AJJO-05-05-04OG	U1/2"X20	U7/16"X20	27	30	14	17	
AJJO-06OG	U9/16"X18	U9/16"X18	27	31.8	14	19	
AJJO-06-06-04OG	U9/16"X18	U7/16"X20	27	30.1	14	17	
AJJO-06-06-05OG	U9/16"X18	U1/2"X20	27	30	14	17	
AJJO-06-06-08OG	U9/16"X18	U3/4"X16	30	37.5	19	24	
AJJO-08OG	U3/4"X16	U3/4"X16	30	36.8	19	24	
AJJO-08-08-06OG	U3/4"X16	U9/16"X18	30	33.5	19	19	
AJJO-08-08-10OG	U3/4"X16	U7/8"X14	33	44	22	27	
AJJO-10OG	U7/8"X14	U7/8"X14	33	44	22	27	
AJJO-10-10-08OG	U7/8"X14	U3/4"X16	33	39.5	22	24	
AJJO-12OG	U1.1/16"X12	U1.1/16"X12	33	51	24	32	
AJJO-12-12-08OG	U1.1/16"X12	U3/4"X16	33	43	24	24	
AJJO-12-12-10OG	U1.1/16"X12	U7/8"X14	33	49	24	27	
AJJO-16OG	U1.5/16"X12	U1.5/16"X12	49	54.5	33	41	
AJJO-20OG	U1.5/8"X12	U1.5/8"X12	57	59	44	50	

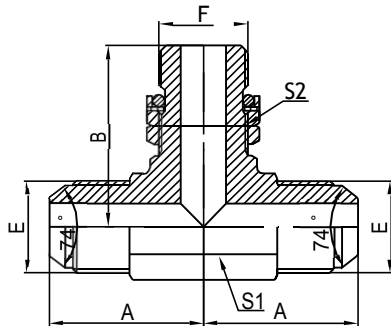

# AJGJ-OG

JIC外螺纹74°外锥/  
英管外螺纹O型圈分支三通  
JIC MALE 74° CONE/  
BSP MALE O-RING BRANCH TEE

代号 PART NO.	螺纹 THREADE		尺寸 DIMENSIONS				
	E	F	A	B	S1	S2	
AJGJ-04-02-04OG	U7 / 16"X20	G1 / 8"X28	24	26.2	11	14	
AJGJ-04OG	U7 / 16"X20	G1 / 4"X19	27	31.8	14	19	
AJGJ-05-02-05OG	U1/2"X20	G1/8"X28	27	29	14	19	
AJGJ-05-04-05OG	U1 / 2"X20	G1 / 4"X19	27	31.8	14	19	
AJGJ-06-04-06OG	U9 / 16"X18	G1 / 4"X19	27	31	14	19	
AJGJ-06OG	U9 / 16"X18	G3 / 8"X19	28	36.8	17	22	
AJGJ-08-06-08OG	U3/4"X16	G3/8"X19	30	37	19	22	
AJGJ-08OG	U3/4"X16	G1/2"X14	33	43.2	22	27	
AJGJ-10-08-10OG	U7/8"X16	G1/2"X14	33	43.5	22	27	
AJGJ-12OG	U1.1 / 16"X12	G3 / 4"X14	33	51	24	32	
AJGJ-16OG	U1.5/16"X12	G1"X11	49	53	33	41	

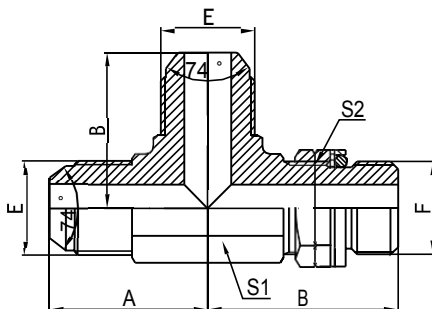

# AJJG-OG

JIC外螺纹74°外锥/  
英管外螺纹O型圈主支三通  
JIC MALE 74° CONE/  
BSP MALE O-RING RUN TEE

代号 PART NO.	螺纹 THREADE		尺寸 DIMENSIONS				
	E	F	A	B	S1	S2	
AJJG-04OG	U7/16"X20	G1/4"X19	27	31.9	14	19	
AJJG-05-05-04OG	U1/2"X20	G1/4"X19	27	31.3	14	19	
AJJG-06OG	U9/16"X18	G3/8"X19	28	36.8	17	22	
AJJG-06-06-04OG	U9/16"X18	G1/4"X19	27	31.3	14	19	
AJJG-08-08-06OG	U3/4"X16	G3/8"X19	30	36.8	19	22	
AJJG-08OG	U3/4"X16	G1/2"X14	33	43.2	22	27	
AJJG-10-10-08OG	U7/8"X16	G1/2"X14	33	44	22	27	
AJJG-12OG	U1.1/16"X12	G3/4"X14	33	49.5	24	32	
AJJG-16OG	U1.5/16"X12	G1"X11	49	53	33	41	

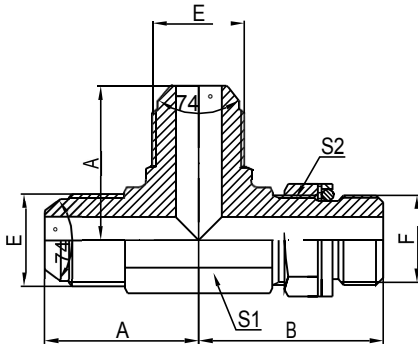

# AJJH-OG

美制JIC外螺纹74°外锥/  
公制外螺纹可调向柱端主支三通  
JIC MALE 74° CONE/METRIC MALE  
ADJUSTABLE STUD END

代号 PART NO.	螺纹 THREADS		尺寸 DIMENSIONS				
	E	F	A	B	S1	S2	
AJJH-04-04-10OG	U7/16"X20	M10x1	24	26.5	11	14	
AJJH-04-04-12OG	U7/16"X20	M12x1.5	27	32.5	14	17	
AJJH-05-05-12OG	U1/2"X20	M12x1.5	27	32	14	17	
AJJH-05-05-14OG	U1/2"X20	M14x1.5	27	32	14	19	
AJJH-06-06-14OG	U9/16"X18	M14x1.5	27	32	14	19	
AJJH-06-06-16OG	U9/16"X18	M16x1.5	28	34.8	17	22	
AJJH-08-08-16OG	U3/4"X16	M16x1.5	30	36	19	22	
AJJH-08-08-18OG	U3/4"X16	M18x1.5	30	37	19	24	
AJJH-10-10-18OG	U7/8"X14	M18x1.5	33	39.5	22	24	
AJJH-10-10-22OG	U7/8"X14	M22x1.5	33	40.2	22	27	
AJJH-12-12-22OG	U1.1/16"X12	M22x1.5	33	44	24	27	
AJJH-12-12-27OG	U1.1/16"X12	M27x2	40	48.5	27	32	
AJJH-16-16-27OG	U1.5/16"X12	M27x2	49	52	33	32	

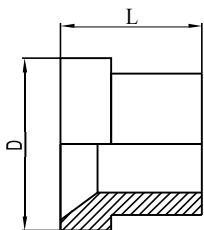

# NB500

JIC公制管衬套  
JIC METRIC SLEEVE

代号 PART NO.	螺纹 THREADE		管子外径 TUBE O.D.		尺寸 DIMENSIONS				
			mm		D		L		
NB500-06	U7/16"X20		6		9.7		10.4		
NB500-08	U1/2"X20		8		11.3		11.2		
NB500-10	U9/16"X18		10		12.7		12.7		
NB500-12	U3/4"X16		12		17.3		14.2		
NB500-14	U7/8"X16		14		20.2		16.8		
NB500-15	U7/8"X16		15		20.2		16.8		
NB500-16	U7/8"X16		16		20.2		16.8		
NB500-18	U1.1/16"X12		18		24.7		17.3		
NB500-20A	U1.1/16"X12		20		24.7		17.3		
NB500-20	U1.3/16"X12		20		27.8		19.3		
NB500-22	U1.3/16"X12		22		27.8		19.3		
NB500-25	U1.5/16"X12		25		31		19.8		
NB500-28	U1.5/8"X12		28		38.9		23.1		
NB500-30	U1.5/8"X12		30		38.9		23.1		
NB500-32	U1.5/8"X12		32		38.9		23.1		
NB500-35	U1.7/8"X12		35		45.3		28.4		
NB500-38	U1.7/8"X12		38		45.3		28.4		
NB500-50	U2.1/2"X12		50		61.2		30.2		



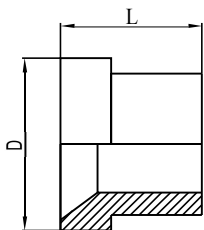

# NB300

JIC英制管衬套  
JIC INCH SLEEVE

代号 PART NO.	螺纹 THREADE		管子外径 TUBE O.D.		尺寸 DIMENSIONS				
			in		D		L		
NB300-04	U7/16"X20		1/4"		9.5		10.5		
NB300-06	U9/16"X18		3/8"		12.5		13		
NB300-08	U3/4"X16		1/2"		17		14		
NB300-10	U7/8"X16		5/8"		20		17		
NB300-12	U1.1/16"X12		3/4"		24.5		17.5		
NB300-16	U1.5/16"X12		1"		31		20		
NB300-20	U1.5/8"X12		1.1/4"		39		23.5		

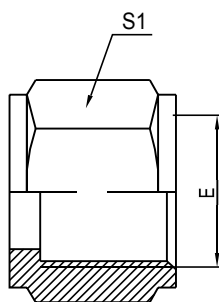

# 00TSUM-NB

美制JIC扩口管接头螺母  
JIC FLARE TUBE END NUT

代号 PART NO.	螺纹 THREADE				尺寸 DIMENSIONS				
	E				S1				
00TSUM-04NB	U7/16"X20				17				
00TSUM-06NB	U9/16"X18				19				
00TSUM-08NB	U3/4"X16				24				
00TSUM-10NB	U7/8"X16				27				
00TSUM-12NB	U1.1/16"X12				32				
00TSUM-16NB	U1.5/16"X12				38				
00TSUM-20NB	U1.5/8"X12				50				
00TSUM-24NB	U1.7/8"X12				55				

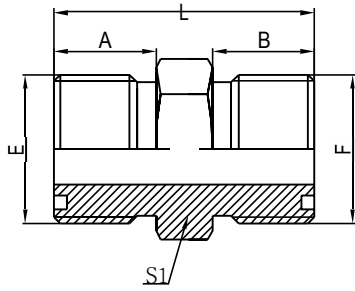

# 1F

美制ORFS外螺纹O型圈平面密封  
ORFS MALE O-RING

代号 PART NO.	螺纹 THREADE		尺寸 DIMENSIONS				
	E	F	A	B	S1	L	
1F-04	U9/16"X18	U9/16"X18	12	12	17	30	
1F-04-06	U9/16"X18	U11/16"X16	12	14	19	32	
1F-04-08	U9/16"X18	U13/16"X16	12	15	22	36	
1F-06	U11/16"X16	U11/16"X16	14	14	19	34	
1F-06-08	U11/16"X16	U13/16"X16	14	15	22	38	
1F-06-10	U11/16"X16	U1"X14	14	16.5	27	39.5	
1F-08	U13/16"X16	U13/16"X16	15	15	22	39	
1F-08-10	U13/16"X16	U1"X14	15	16.5	27	40.5	
1F-08-12	U13/16"X16	U1.3/16"X12	15	17	32	41	
1F-10	U1"X14	U1"X14	16.5	16.5	27	42	
1F-10-12	U1"X14	U1.3/16"X12	16.5	17	32	42.5	
1F-12	U1.3/16"X12	U1.3/16"X12	17	17	32	43	
1F-12-16	U1.3/16"X12	U1.7/16"X12	17	18.5	41	47.5	
1F-12-20	U1.3/16"X12	U1.11/16"X12	17	19.5	46	50	
1F-16	U1.7/16"X12	U1.7/16"X12	18.5	18.5	41	49	
1F-16-20	U1.7/16"X12	U1.11/16"X12	18.5	19.5	46	51.5	
1F-20	U1.11/16"X12	U1.11/16"X12	19.5	19.5	46	52.5	
1F-24	U2"X12	U2"X12	23.5	23.5	55	64	

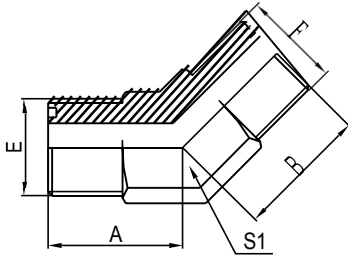

# 1F4

45° 美制ORFS外螺纹O型圈平面密封  
45° ORFS MALE O-RING

代号 PART NO.	螺纹 THREADE		尺寸 DIMENSIONS				
	E	F	A	B	S1		
1F4-04	U9/16"X18	U9/16"X18	22	22	14		
1F4-04-06	U9/16"X18	U11/16"X16	25	25	19		
1F4-06	U11/16"X16	U11/16"X16	25	25	19		
1F4-06-08	U11/16"X16	U13/16"X16	27	27	22		
1F4-08	U13/16"X16	U13/16"X16	27	27	22		
1F4-08-12	U13/16"X16	U1.3/16"X12	37	37	33		
1F4-10	U1"X14	U1"X14	33	33	27		
1F4-12	U1.3/16"X12	U1.3/16"X12	37	37	33		
1F4-16	U1.7/16"X12	U1.7/16"X12	40	40	44		
1F4-20	U1.11/16"X12	U1.11/16"X12	40	40	44		
1F4-24	U2"X12	U2"X12	47	47	53		

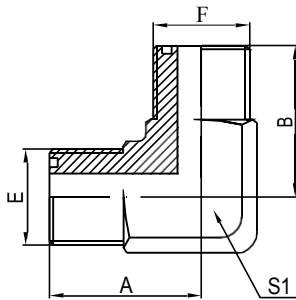

# 1F9

90° 美制ORFS外螺纹O型圈平面密封  
90° ORFS MALE O-RING

代号 PART NO.	螺纹 THREADE		尺寸 DIMENSIONS				
	E	F	A	B	S1		
1F9-04	U9/16"X18	U9/16"X18	29	27	14		
1F9-04-06	U9/16"X18	U11/16"X16	30	29	17		
1F9-06	U11/16"X16	U11/16"X16	30	29	17		
1F9-06-08	U11/16"X16	U13/16"X16	37	37	22		
1F9-08	U13/16"X16	U13/16"X16	37	37	22		
1F9-08-12	U13/16"X16	U1.3/16"X12	40	52	27		
1F9-10	U1"X14	U1"X14	40	43	27		
1F9-12	U1.3/16"X12	U1.3/16"X12	40	47	27		
1F9-16	U1.7/16"X12	U1.7/16"X12	45	55	33		
1F9-20	U1.11/16"X12	U1.11/16"X12	57	55	44		
1F9-24	U2"X12	U2"X12	57	57	48		

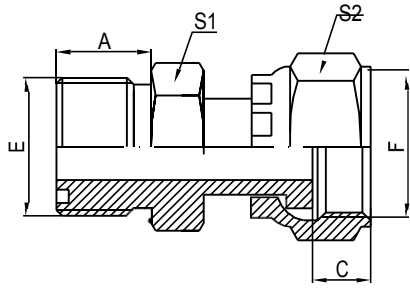

# 2F

美制ORFS外螺纹O型圈平面密封/ ORFS内螺纹  
ORFS MALE O-RING/ORFS FEMALE

代号 PART NO.	螺纹 THREADE		尺寸 DIMENSIONS				
	E	F	A	C	S1	S2	
2F-04	U9/16"X18	U9/16"X18	12	10	17	19	
2F-04-06	U9/16"X18	U11/16"X16	12	11	17	22	
2F-04-08	U9/16"X18	U13/16"X16	12	12	19	24	
2F-06-04	U11/16"X16	U11/16"X16	14	10	19	19	
2F-06	U11/16"X16	U11/16"X16	14	11	19	22	
2F-06-08	U11/16"X16	U13/16"X16	14	12	19	24	
2F-06-10	U11/16"X16	U1"X14	14	13.5	24	32	
2F-08-06	U13/16"X16	U11/16"X16	15	11	22	22	
2F-08	U13/16"X16	U13/16"X16	15	12	22	24	
2F-08-10	U13/16"X16	U1"X14	15	13.5	24	32	
2F-08-12	U13/16"X16	U1.3/16"X12	15	13.5	30	36	
2F-10-08	U1"X14	U13/16"X16	16.5	12	27	24	
2F-10	U1"X14	U1"X14	16.5	13.5	27	32	
2F-10-12	U1"X14	U1.3/16"X12	16.5	13.5	30	36	
2F-10-16	U1"X14	U1.7/16"X12	16.5	14.5	36	41	
2F-12-08	U1.3/16"X12	U13/16"X16	17	12	32	24	
2F-12-10	U1.3/16"X12	U1"X14	17	13.5	32	32	
2F-12	U1.3/16"X12	U1.3/16"X12	17	13.5	32	36	
2F-12-16	U1.3/16"X12	U1.7/16"X12	17	14.5	36	41	
2F-16-12	U1.7/16"X12	U1.3/16"X12	18.5	13.5	41	36	
2F-16	U1.7/16"X12	U1.7/16"X12	18.5	14.5	41	41	
2F-16-20	U1.7/16"X12	U1.11/16"X12	18.5	15.5	41	50	
2F-20-16	U1.11/16"X12	U1.7/16"X12	19.5	14.5	46	41	
2F-20	U1.11/16"X12	U1.11/16"X12	19.5	15.5	46	50	

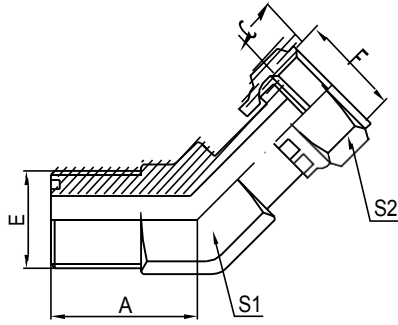

## 2F4

45° 美制ORFS外螺纹O型  
圈平面密封/ ORFS内螺纹  
45° ORFS MALE  
O-RING/ORFS FEMALE

代号 PART NO.	螺纹 THREADE		尺寸 DIMENSIONS				
	E	F	A	C	S1	S2	
2F4-04	U9 / 16"X18	U9 / 16"X18	22	10	14	19	
2F4-06	U11/16"X16	U11/16"X16	22	11	17	22	
2F4-08	U13/16"X16	U13/16"X16	27	12	22	24	
2F4-10	U1"X14	U1"X14	33	13.5	27	32	
2F4-12	U1.3 / 16"X12	U1.3 / 16"X12	37	13.5	33	36	
2F4-16	U1.7 / 16"X12	U1.7 / 16"X12	40	14.5	44	41	
2F4-20	U1.11 / 16"X12	U1.11 / 16"X12	40	15.5	44	50	

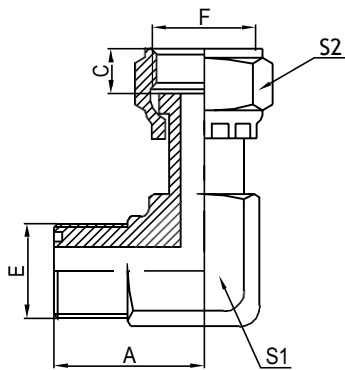

## 2F9

90° 美制ORFS外螺纹O型  
圈平面密封/ ORFS内螺纹  
90° ORFS MALE  
O-RING/ORFS FEMALE

代号 PART NO.	螺纹 THREADE		尺寸 DIMENSIONS				
	E	F	A	C	S1	S2	
2F9-04	U9/16"X18	U9/16"X18	29	10	14	19	
2F9-06	U11/16"X16	U11/16"X16	30	11	17	22	
2F9-08	U13/16"X16	U13/16"X16	37	12	22	24	
2F9-10	U1"X14	U1"X14	40	13.5	27	32	
2F9-12	U1.3 / 16"X12	U1.3 / 16"X12	40	13.5	27	36	
2F9-16	U1.7 / 16"X12	U1.7 / 16"X12	45	14.5	33	41	
2F9-20	U1.11 / 16"X12	U1.11 / 16"X12	57	15.5	44	50	

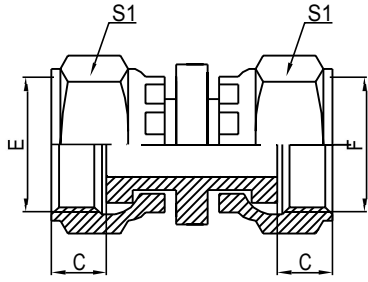

# 3F

美制ORFS内螺纹  
ORFS FEMALE

代号 PART NO.	螺纹 THREADE		尺寸 DIMENSIONS				
	E	F	C	S1			
3F-04	U9/16"X18	U9/16"X18	10	19			
3F-06	U11/16"X16	U11/16"X16	11	22			
3F-08	U13/16"X16	U13/16"X16	12	24			
3F-10	U1"X14	U1"X14	13.5	32			
3F-12	U1.3/16"X12	U1.3/16"X12	13.5	36			
3F-16	U1.7/16"X12	U1.7/16"X12	14.5	41			
3F-20	U1.11/16"X12	U1.11/16"X12	15.5	50			

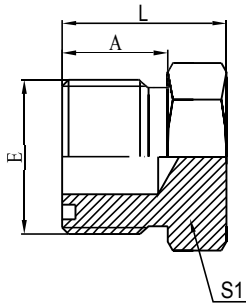

# 4F

美制ORFS外螺纹O型圈平面密封堵头  
ORFS MALE O-RING PLUG

代号 PART NO.	螺纹 THREADE		尺寸 DIMENSIONS				
	E		A	S1		L	
4F-04	U9/16"X18		12	19		18	
4F-06	U11/16"X16		14	22		22	
4F-08	U13/16"X16		15	27		24	
4F-10	U1"X14		16.5	30		26	
4F-12	U1.3/16"X12		17	36		27	
4F-16	U1.7/16"X12		18.5	41		30	
4F-20	U1.11/16"X12		19.5	50		36	

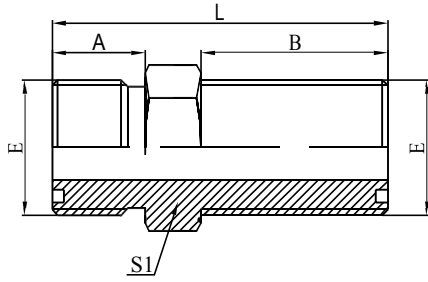

# 6F

美制ORFS外螺纹O型圈平面密封过板接头  
ORFS MALE O-RING BULKHEAD

代号 PART NO.	螺纹 THREADE				尺寸 DIMENSIONS				
	E				A	B	S1		L
6F-04	U9/16"X18				12	31.5	19		49.5
6F-06	U11/16"X16				14	34	22		56
6F-08	U13/16"X16				15	36.5	27		61
6F-10	U1"X14				16.5	40.6	30		67
6F-12	U1.3/16"X12				17	41.7	36		70
6F-16	U1.7/16"X12				18.5	42.2	41		72
6F-20	U1.11/16"X12				19.5	42.2	50		79

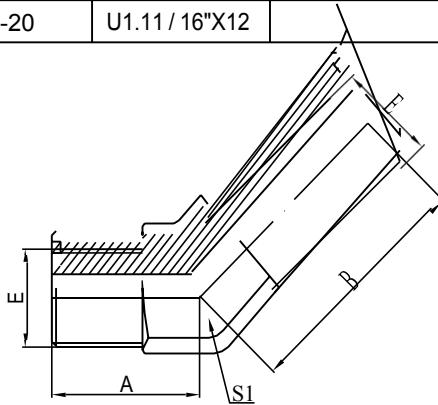

# 6F4

45° 美制ORFS外螺纹O型圈平面密封过板接头  
45° ORFS MALE O-RING BULKHEAD

代号 PART NO.	螺纹 THREADE				尺寸 DIMENSIONS				
	E				A	B	S1		
6F4-04	U9/16"X18				22	42.4	14		
6F4-06	U11/16"X16				22	48.5	17		
6F4-08	U13/16"X16				27	51	22		
6F4-10	U1"X14				33	56.6	27		
6F4-12	U1.3/16"X12				37	60.7	33		
6F4-16	U1.7/16"X12				40	65.2	44		

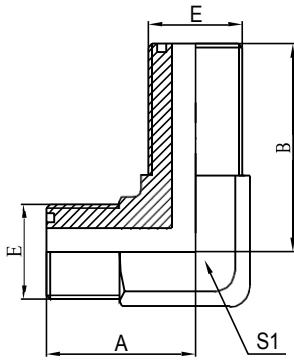

# 6F9

90° 美制ORFS外螺纹O型圈平面密封过板接头  
90° ORFS MALE O-RING BULKHEAD

代号 PART NO.	螺纹 THREADE				尺寸 DIMENSIONS				
	E				A	B	S1		
6F9-04	U9/16"X18				29	47	14		
6F9-06	U11/16"X16				30	52	17		
6F9-08	U13/16"X16				37	55.5	22		
6F9-10	U1"X14				40	63	27		
6F9-12	U1.3/16"X12				40	67.2	27		
6F9-16	U1.7/16"X12				45	71.2	33		



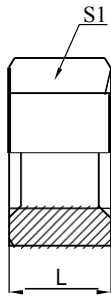

# 8F

美制ORFS锁母  
ORFS LOCK NUT

代号 PART NO.	螺纹 THREADE				尺寸 DIMENSIONS			
	E				A	S1		
8F-04	U9/16"X18				7	19		
8F-06	U11/16"X16				8	22		
8F-08	U13/16"X16				9	27		
8F-10	U1"X14				10.4	30		
8F-12	U1.3/16"X12				10.4	36		
8F-16	U1.7/16"X12				10.4	41		
8F-20	U1.11/16"X12				10.4	50		
8F-24	U2"X12				10.4	60		

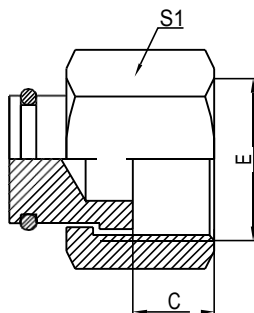

# 9F

美制ORFS内螺纹堵头  
ORFS FEMALE PLUG

代号 PART NO.	螺纹 THREADE				尺寸 DIMENSIONS			
	E				C	S1		
9F-04	U9/16"X18				11	19		
9F-06	U11/16"X16				10	22		
9F-08	U13/16"X16				11	27		
9F-10	U1"X14				13.5	30		
9F-12	U1.3/16"X12				13	36		
9F-16	U1.7/16"X12				15	41		
9F-20	U1.11/16"X12				17.5	50		

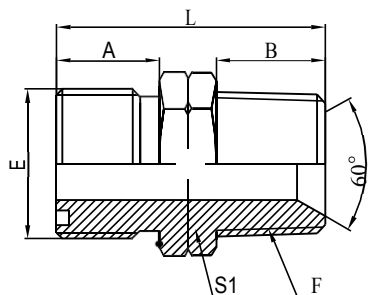

# 1FN

美制ORFS外螺纹O型圈平面密封/  
布锥管外螺纹  
ORFS MALE O-RING/  
NPT MALE

代号 PART NO.	螺纹 THREADE		尺寸 DIMENSIONS				
	E	F	A	B	S1	L	
1FN-04-02	U9/16"X18	Z1/8"X27	10	10	17	26	
1FN-04	U9/16"X18	Z1/4"X18	10	14	17	30	
1FN-04-06	U9/16"X18	Z3/8"X18	10	14	17	30	
1FN-06-04	U11/16"X16	Z1/4"X18	11	14	19	31	
1FN-06	U11/16"X16	Z3/8"X18	11	14	19	31	
1FN-06-08	U11/16"X16	Z1/2"X14	11	19	22	38	
1FN-08-04	U13/16"X16	Z1/4"X18	12	14	22	34	
1FN-08-06	U13/16"X16	Z3/8"X18	12	14	22	34	
1FN-08	U13/16"X16	Z1/2"X14	12	19	22	39	
1FN-08-12	U13/16"X16	Z3/4"X14	12	19.5	27	40	
1FN-10-08	U1"X14	Z1/2"X14	13.5	19	27	41	
1FN-10-12	U1"X14	Z3/4"X14	13.5	19.5	27	42	
1FN-12-08	U1.3/16"X12	Z1/2"X14	13.5	19	32	41	
1FN-12	U1.3/16"X12	Z3/4"X14	13.5	19.5	32	42	
1FN-12-16	U1.3/16"X12	Z1"X11.5	13.5	24	36	48	
1FN-16-12	U1.7/16"X12	Z3/4"X14	14.5	19.5	41	46	
1FN-16	U1.7/16"X12	Z1"X11.5	14.5	24	41	51	
1FN-16-20	U1.7/16"X12	Z1.1/4"X11.5	14.5	25	46	53	
1FN-20-16	U1.11/16"X12	Z1"X11.5	15.5	24	46	53	
1FN-20	U1.11/16"X12	Z1.1/4"X11.5	15.5	25	46	54	
1FN-20-24	U1.11/16"X12	Z1.1/2"X11.5	15.5	25	50	57	

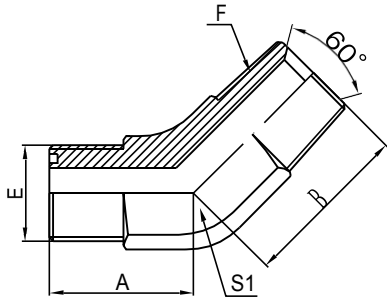

# 1FN4

45° 美制ORFS外螺纹O型圈平面密封/  
布锥管外螺纹45°  
ORFS MALE O-RING/  
NPT MALE

代号 PART NO.	螺纹 THREADS		尺寸 DIMENSIONS				
	E	F	A	B	S1		
1FN4-04-02	U9/16"X18	Z1/8"X27	22	22	14		
1FN4-04	U9/16"X18	Z1/4"X18	22	22	14		
1FN4-04-06	U9/16"X18	Z3/8"X18	22	22	17		
1FN4-06-04	U11/16"X16	Z1/4"X18	25	25	19		
1FN4-06	U11/16"X16	Z3/8"X18	25	25	19		
1FN4-06-08	U11/16"X16	Z1/2"X14	27	27	22		
1FN4-08-06	U13/16"X16	Z3/8"X18	27	27	22		
1FN4-08	U13/16"X16	Z1/2"X14	27	27	22		
1FN4-10-08	U1"X14	Z1/2"X14	33	33	27		
1FN4-12	U1.3/16"X12	Z3/4"X14	37	37	33		
1FN4-16	U1.7/16"X12	Z1"X11.5	40	40	44		
1FN4-20	U1.11/16"X12	Z1.1/4"X11.5	40	40	44		

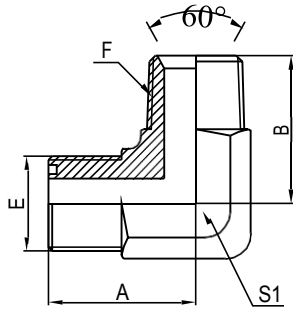

# 1FN9

90° 美制ORFS外螺纹O型圈平面密封/  
布锥管外螺纹90°  
ORFS MALE O-RING/  
NPT MALE

代号 PART NO.	螺纹 THREADS		尺寸 DIMENSIONS				
	E	F	A	B	S1		
1FN9-04-02	U9/16"X18	Z1/8"X27	29	27	14		
1FN9-04	U9/16"X18	Z1/4"X18	29	27	14		
1FN9-06-04	U11/16"X16	Z1/4"X18	33	33	19		
1FN9-06	U11/16"X16	Z3/8"X18	33	33	19		
1FN9-06-08	U11/16"X16	Z1/2"X14	37	37	22		
1FN9-08-06	U13/16"X16	Z3/8"X18	37	37	22		
1FN9-08	U13/16"X16	Z1/2"X14	37	37	22		
1FN9-08-12	U13/16"X16	Z3/4"X14	40	40	27		
1FN9-10-08	U1"X14	Z1/2"X14	40	40	27		
1FN9-10-12	U1"X14	Z3/4"X14	40	40	27		
1FN9-12-08	U1.3/16"X12	Z1/2"X14	40	40	27		
1FN9-12	U1.3/16"X12	Z3/4"X14	40	40	27		
1FN9-12-16	U1.3/16"X12	Z1"X11.5	45	45	33		
1FN9-16-12	U1.7/16"X12	Z3/4"X14	45	45	33		
1FN9-16	U1.7/16"X12	Z1"X11.5	45	45	33		
1FN9-20-16	U1.11/16"X12	Z1"X11.5	57	57	44		
1FN9-20	U1.11/16"X12	Z1.1/4"X11.5	57	57	44		

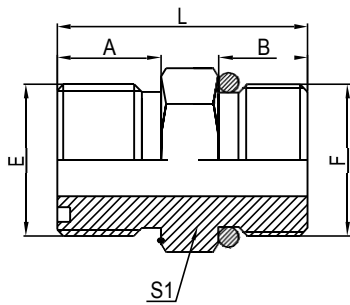

# 1FH

美制ORFS外螺纹O型圈平面密封/公制外螺纹  
ORFS MALE O-RING/METRIC MALE O-RING

代号 PART NO.	螺纹 THREADE		尺寸 DIMENSIONS				
	E	F	A	B	S1	L	
1FH-04-10	U9/16"X18	M10x1	12	11	17	29	
1FH-04-12	U9/16"X18	M12x1.5	12	11	17	29	
1FH-06-12	U11/16"X16	M12x1.5	14	11	19	31	
1FH-06-14	U11/16"X16	M14x1.5	14	11	19	31	
1FH-06-16	U11/16"X16	M16x1.5	14	11	22	33	
1FH-08-16	U13/16"X16	M16x1.5	15	11	22	34	
1FH-08-18	U13/16"X16	M18x1.5	15	11	24	34	
1FH-08-22	U13/16"X16	M22x1.5	15	12	27	36	
1FH-10-22	U1"X14	M22x1.5	16.5	12	27	37	
1FH-12-22	U1.3/16"X12	M22x1.5	17	12	32	38	
1FH-12-27	U1.3/16"X12	M27x2	17	13	32	39	

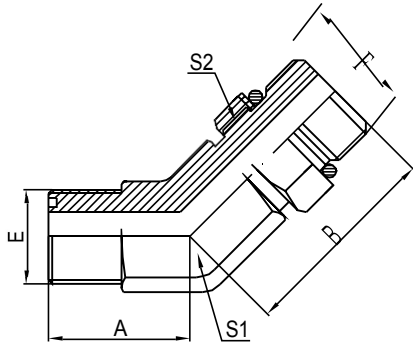

# 1FH4-OG

45° 美制ORFS外螺纹O型圈平面密封/  
公制外螺纹可调向柱端 45°  
ORFS MALE O-RING/ METRIC  
MALE ADJUSTABLE STUD END

代号 PART NO.	螺纹 THREADE		尺寸 DIMENSIONS				
	E	F	A	B	S1		
1FH4-04-14OG	U9 / 16"X18	M14x1.5	22	29.5	14		
1FH4-06-14OG	U11/16"X16	M14x1.5	25	33	19		
1FH4-06-16OG	U11/16"X16	M16x1.5	25	33.5	19		
1FH4-08-16OG	U13/16"X16	M16x1.5	27	33.5	22		
1FH4-08-18OG	U13/16"X16	M18x1.5	27	36	22		
1FH4-10-22OG	U1"X14	M22x1.5	33	38.5	27		
1FH4-12-22OG	U1.3 / 16"X12	M22x1.5	37	39.5	33		
1FH4-12-27OG	U1.3 / 16"X12	M27x2	37	40	33		

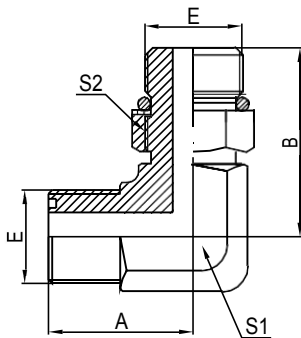

# 1FH9-OG

90° 美制ORFS外螺纹O型圈平面密封/  
公制外螺纹可调向柱端  
90° ORFS MALE O-RING/ METRIC  
MALE ADJUSTABLE STUD END

代号 PART NO.	螺纹 THREADE		尺寸 DIMENSIONS				
	E	F	A	B	S1		
1FH9-04-12OG	U9/16"X18	M12x1.5	29	32	14		
1FH9-06-14OG	U11/16"X16	M14x1.5	33	35.5	19		
1FH9-06-16OG	U11/16"X16	M16x1.5	33	38	19		
1FH9-08-16OG	U13/16"X16	M16x1.5	37	40.5	22		
1FH9-08-18OG	U13/16"X16	M18x1.5	37	43	22		
1FH9-08-22OG	U13/16"X16	M22x1.5	40	44.5	27		
1FH9-10-22OG	U1"X14	M22x1.5	40	48	27		
1FH9-12-27OG	U1.3 / 16"X12	M27x2	40	50	27		

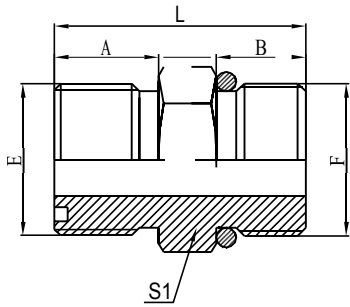

# 1FO

美制ORFS外螺纹O型圈平面密封/  
美制外螺纹带O型圈重系列  
ORFS MALE O-RING/  
SAE O-RING BOSS S-SERIES

代号 PART NO.	螺纹 THREADS		尺寸 DIMENSIONS				
	E	F	A	B	S1	L	
1FO-04	U9/16"X18	U7/16"X20	12	10	17	28	
1FO-04-05	U9/16"X18	U1/2"X20	12	10	17	28	
1FO-04-06	U9/16"X18	U9/16"X18	12	12	17	30	
1FO-04-08	U9/16"X18	U3/4"X16	12	12	22	32	
1FO-06-04	U11/16"X16	U7/16"X20	14	10	19	30	
1FO-06-05	U11/16"X16	U1/2"X20	14	10	19	30	
1FO-06	U11/16"X16	U9/16"X18	14	12	19	32	
1FO-06-08	U11/16"X16	U3/4"X16	14	12	22	34	
1FO-06-10	U11/16"X16	U7/8"X14	14	13.5	27	37	
1FO-08-06	U13/16"X16	U9/16"X18	15	12	22	35	
1FO-08	U13/16"X16	U3/4"X16	15	12	22	35	
1FO-08-10	U13/16"X16	U7/8"X14	15	13.5	27	38	
1FO-08-12	U13/16"X16	U1.1/16"X12	15	16	32	40	
1FO-10	U1"X14	U7/8"X14	16.5	13.5	27	39	
1FO-10-08	U1"X14	U3/4"X16	16.5	12	27	38	
1FO-10-12	U1"X14	U1.1/16"X12	16.5	16	32	42	
1FO-12-10	U1.3/16"X12	U7/8"X14	17	13.5	32	41	
1FO-12	U1.3/16"X12	U1.1/16"X12	17	16	32	42	
1FO-12-16	U1.3/16"X12	U1.5/16"X12	17	17	41	46	
1FO-16-12	U1.7/16"X12	U1.1/16"X12	18.5	16	41	46	
1FO-16	U1.7/16"X12	U1.5/16"X12	18.5	17	41	47	
1FO-16-20	U1.7/16"X12	U1.5/8"X12	18.5	18	50	53	
1FO-20-16	U1.11/16"X12	U1.5/16"X12	19.5	17	46	50	
1FO-20	U1.11/16"X12	U1.5/8"X12	19.5	18	50	54	

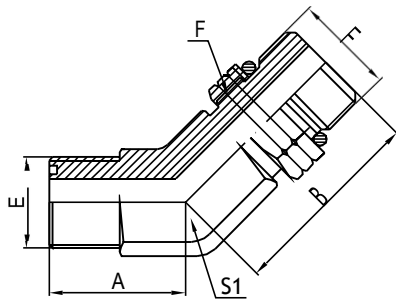

# 1FO4-OG

45° 美制ORFS外螺纹O型圈平面密封/  
 美制SAE外螺纹带O型圈45°  
 ORFS MALE O-RING/  
 SAE O-RING BOSS

代号 PART NO.	螺纹 THREADS		尺寸 DIMENSIONS				
	E	F	A	B	S1	S2	
1FO4-04OG	U9/16"X18	U7/16"X20	22	26	14	17	
1FO4-04-06OG	U9/16"X18	U9/16"X18	22	28	14	19	
1FO4-06-04OG	U11/16"X16	U7/16"X20	25	27.3	19	17	
1FO4-06OG	U11/16"X16	U9/16"X18	25	29.5	19	19	
1FO4-06-08OG	U11/16"X16	U3/4"X16	25	32.5	19	24	
1FO4-08-06OG	U13/16"X16	U9/16"X18	27	30.8	22	19	
1FO4-08OG	U13/16"X16	U3/4"X16	27	34	22	24	
1FO4-08-10OG	U13/16"X16	U7/8"X14	27	39.5	22	27	
1FO4-08-12OG	U13/16"X16	U1.1/16"X12	33	44	27	32	
1FO4-10-08OG	U1"X14	U3/4"X16	33	34	27	24	
1FO4-10OG	U1"X14	U7/8"X14	33	41.5	27	27	
1FO4-10-12OG	U1"X14	U1.1/16"X12	33	44	27	32	
1FO4-12-10OG	U1.3/16"X12	U7/8"X14	37	42	33	27	
1FO4-12OG	U1.3/16"X12	U1.1/16"X12	37	45.5	33	32	
1FO4-12-16OG	U1.3/16"X12	U1.5/16"X12	37	47.9	33	41	
1FO4-16-12OG	U1.7/16"X12	U1.1/16"X12	40	47.9	44	32	
1FO4-16OG	U1.7/16"X12	U1.5/16"X12	40	47.9	44	41	
1FO4-16-20OG	U1.7/16"X12	U1.5/8"X12	40	48.5	44	50	
1FO4-20OG	U1.11/16"X12	U1.5/8"X12	40	48.8	44	50	
1FO4-20-24OG	U1.11/16"X12	U1.7/8"X12	47	51	53	55	



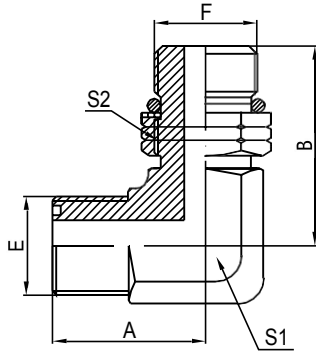

# 1FO9-OG

90° 美制ORFS外螺纹O型圈平面密封/  
美制SAE外螺纹带O型圈90°  
ORFS MALE O-RING/  
SAE O-RING BOSS

代号 PART NO.	螺纹 THREADS		尺寸 DIMENSIONS				
	E	F	A	B	S1	S2	
1FO9-04OG	U9/16"X18	U7/16"X20	29	30.3	14	17	
1FO9-04-06OG	U9/16"X18	U9/16"X18	29	32	14	19	
1FO9-06-04OG	U11/16"X16	U7/16"X20	33	33.5	19	17	
1FO9-06OG	U11/16"X16	U9/16"X18	33	34.5	19	19	
1FO9-06-08OG	U11/16"X16	U3/4"X16	33	38	19	24	
1FO9-06-10OG	U11/16"X16	U7/8"X14	37	47	22	27	
1FO9-08-06OG	U13/16"X16	U9/16"X18	37	37	22	19	
1FO9-08OG	U13/16"X16	U3/4"X16	37	40.5	22	24	
1FO9-08-10OG	U13/16"X16	U7/8"X14	37	45.3	22	27	
1FO9-08-12OG	U13/16"X16	U1.1/16"X12	40	52	27	32	
1FO9-10-08OG	U1"X14	U3/4"X16	40	45	27	24	
1FO9-10OG	U1"X14	U7/8"X14	40	50.8	27	27	
1FO9-10-12OG	U1"X14	U1.1/16"X12	40	52	27	32	
1FO9-12-10OG	U1.3/16"X12	U7/8"X14	40	52.8	27	27	
1FO9-12OG	U1.3/16"X12	U1.1/16"X12	40	54	27	32	
1FO9-12-16OG	U1.3/16"X12	U1.5/16"X12	45	55.5	33	41	
1FO9-16-12OG	U1.7/16"X12	U1.1/16"X12	45	59	33	32	
1FO9-16OG	U1.7/16"X12	U1.5/16"X12	45	59	33	41	
1FO9-20OG	U1.11/16"X12	U1.5/8"X12	57	60.5	44	50	
1FO9-20-24OG	U1.11/16"X12	U1.7/8"X12	57	66.5	48	55	

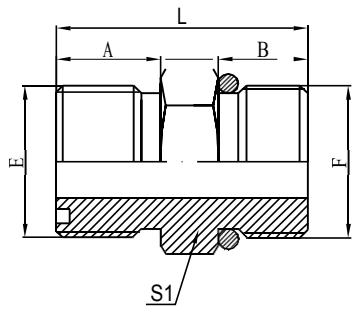

# 1FG

美制ORFS外螺纹O型圈平面密封/  
英管外螺纹O型圈  
ORFS MALE O-RING/  
BSP MALE O-RING

代号 PART NO.	螺纹 THREADS		尺寸 DIMENSIONS				
	E	F	A	B	S1	L	
1FG-04-02	U9/16"X18	G1/8"X28	10	9	17	25	
1FG-04	U9/16"X18	G1/4"X19	10	12	19	28	
1FG-04-06	U9/16"X18	G3/8"X19	10	13.5	22	31	
1FG-06	U11/16"X16	G3/8"X19	11	13.5	22	32	
1FG-06-04	U11/16"X16	G1/4"X19	11	12	19	29	
1FG-06-08	U11/16"X16	G1/2"X14	11	16	27	36	
1FG-08	U13/16"X16	G1/2"X14	12	16	27	37	
1FG-08-06	U13/16"X16	G3/8"X19	12	13.5	22	33	
1FG-08-12	U13/16"X16	G3/4"X14	12	18.5	32	40	
1FG-10-08	U1"X14	G1/2"X14	13.5	16	27	39	
1FG-10-12	U1"X14	G3/4"X14	13.5	18.5	32	42	
1FG-12-08	U1.3/16"X12	G1/2"X14	13.5	16	32	39	
1FG-12	U1.3/16"X12	G3/4"X14	13.5	18.5	32	42	
1FG-12-16	U1.3/16"X12	G1"X11	13.5	20.5	41	46	
1FG-16-12	U1.7/16"X12	G3/4"X14	14.5	18.5	41	45	
1FG-16	U1.7/16"X12	G1"X11	14.5	20.5	41	47	
1FG-20	U1.11/16"X12	G1.1/4"X11	15.5	20.5	50	53	
1FG-20-16	U1.11/16"X12	G1"X11	15.5	20.5	46	49	

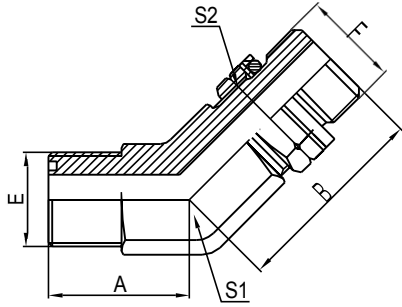

# 1FG4-OG

45° 美制ORFS外螺纹O型圈平面密封/  
 英管外螺纹O型圈45°  
 ORFS MALE O-RING/ BSP  
 MALE O-RING

代号 PART NO.	螺纹 THREADE		尺寸 DIMENSIONS				
	E	F	A	B	S1	S2	
1FG4-04OG	U9/16"X18	G1/4"X19	22	27	14	19	
1FG4-04-02OG	U9/16"X18	G1/8"X28	22	24.8	14	14	
1FG4-04-06OG	U9/16"X18	G3/8"X19	22	30	17	22	
1FG4-06OG	U11/16"X16	G3/8"X19	25	31	19	22	
1FG4-06-04OG	U11/16"X16	G1/4"X19	25	28	19	19	
1FG4-06-08OG	U11/16"X16	G1/2"X14	27	36	22	27	
1FG4-08OG	U13/16"X16	G1/2"X14	27	36	22	27	
1FG4-08-06OG	U13/16"X16	G3/8"X19	27	32	22	22	
1FG4-10-08OG	U1"X14	G1/2"X14	33	37.5	27	27	
1FG4-10-12OG	U1"X14	G3/4"X14	33	42	27	32	
1FG4-12OG	U1.3/16"X12	G3/4"X14	37	42.5	33	32	
1FG4-12-08OG	U1.3/16"X12	G1/2"X14	37	38.5	33	27	
1FG4-12-16OG	U1.3/16"X12	G1"X11	37	44	33	41	
1FG4-16OG	U1.7/16"X12	G1"X11	40	44.5	44	41	
1FG4-16-12OG	U1.7/16"X12	G3/4"X14	40	44.5	44	32	
1FG4-20OG	U1.11/16"X12	G1.1/4"X11	40	47.5	44	50	

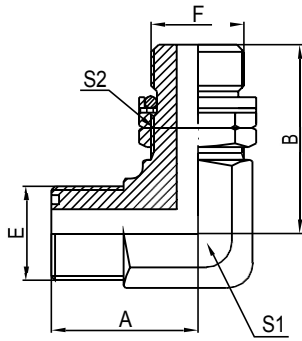

# 1FG9-OG

90° 美制ORFS外螺纹O型圈平面密封/  
 英管外螺纹O型圈90°  
 ORFS MALE O-RING/ BSP  
 MALE O-RING

代号 PART NO.	螺纹 THREADE		尺寸 DIMENSIONS				
	E	F	A	B	S1	S2	
1FG9-04-02OG	U9/16"X18	G1/8"X28	29	29	14	14	
1FG9-04OG	U9/16"X18	G1/4"X19	29	31.3	14	19	
1FG9-04-06OG	U9/16"X18	G3/8"X19	30	35.8	17	22	
1FG9-06-04OG	U11/16"X16	G1/4"X19	33	33.5	19	19	
1FG9-06OG	U11/16"X16	G3/8"X19	33	36.8	19	22	
1FG9-06-08OG	U11/16"X16	G1/2"X14	37	43.2	22	27	
1FG9-08-06OG	U13/16"X16	G3/8"X19	37	39.5	22	22	
1FG9-08OG	U13/16"X16	G1/2"X14	37	43.2	22	27	
1FG9-10-08OG	U1"X14	G1/2"X14	40	46.5	27	27	
1FG9-10-12OG	U1"X14	G3/4"X14	40	49.3	27	32	
1FG9-12-08OG	U1.3/16"X12	G1/2"X14	40	47.5	27	27	
1FG9-12OG	U1.3/16"X12	G3/4"X14	40	52	27	32	
1FG9-12-16OG	U1.3/16"X12	G1"X11	45	53	33	41	
1FG9-16-12OG	U1.7/16"X12	G3/4"X14	45	56	33	32	
1FG9-16OG	U1.7/16"X12	G1"X11	45	56	33	41	
1FG9-20-16OG	U1.11/16"X12	G1"X11	57	60	44	41	
1FG9-20OG	U1.11/16"X12	G1.1/4"X11	57	60	44	50	

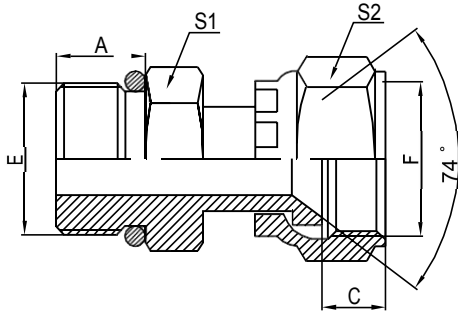

# 20F

美制SAE外螺纹O型圈重系列/  
ORFS 内螺纹  
SAE O-RING BOSS S-SERIES/  
ORFS FEMALE

代号 PART NO.	螺纹 THREADS		尺寸 DIMENSIONS				
	E	F	A	C	S1	S2	
20F-04	U7/16"X20	U9/16"X18	10	10	14	19	
20F-04-06	U7/16"X20	U11/16"X16	10	11	17	22	
20F-06-04	U9/16"X18	U9/16"X18	12	10	17	19	
20F-06	U9/16"X18	U11/16"X16	12	11	17	22	
20F-06-08	U9/16"X18	U13/16"X16	12	12	19	27	
20F-08-06	U3/4"X16	U11/16"X16	12	11	22	22	
20F-08	U3/4"X16	U13/16"X16	12	12	22	27	
20F-10-08	U7/8"X14	U13/16"X16	13.5	12	27	27	
20F-10	U7/8"X14	U1"X14	13.5	13.5	27	32	
20F-12-10	U1.1/16"X12	U1"X14	16	13.5	32	32	
20F-12	U1.1/16"X12	U1.3/16"X12	16	13.5	32	36	
20F-16-12	U1.5/16"X12	U1.3/16"X12	17	13.5	41	36	
20F-16	U1.5/16"X12	U1.7/16"X12	17	14.5	41	41	
20F-20-16	U1.5/8"X12	U1.7/16"X12	18	14.5	50	41	
20F-20	U1.5/8"X12	U1.11/16"X12	18	15.5	50	50	

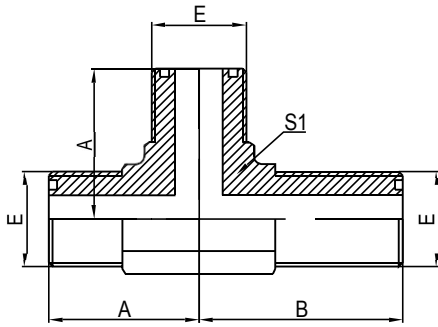

# AFF6F

美制ORFS外螺纹O型圈平面密封过板接头主支三通  
ORFS MALE O-RING  
BULKHEAD RUN TEE

代号 PART NO.	螺纹 THREADE				尺寸 DIMENSIONS				
	E				A	B	S1		
AFF6F-04	U9 / 16"X18				27	47	14		
AFF6F-06	U11/16"X16				30	52	19		
AFF6F-08	U13/16"X16				33	55.5	22		
AFF6F-10	U1"X14				33	63	24		
AFF6F-12	U1.3 / 16"X12				40	67.2	27		
AFF6F-16	U1.7 / 16"X12				45	71.2	33		
AFF6F-20	U1.11 / 16"X12				57	75.5	44		

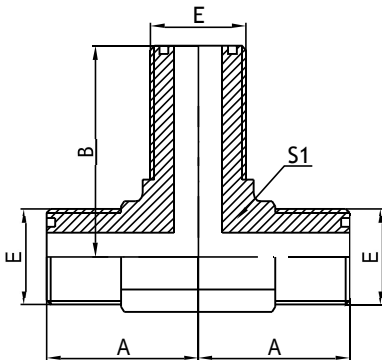

# AF6FF

美制ORFS外螺纹O型圈平面密封过板接头分支三通  
ORFS MALE O-RING  
BULKHEAD BRANCH TEE

代号 PART NO.	螺纹 THREADE				尺寸 DIMENSIONS				
	E				A	B	S1		
AF6FF-04	U9/16"X18				27	47	14		
AF6FF-06	U11/16"X16				30	52	19		
AF6FF-08	U13/16"X16				33	55.5	22		
AF6FF-10	U1"X14				33	63	24		
AF6FF-12	U1.3 / 16"X12				40	67.2	27		
AF6FF-16	U1.7 / 16"X12				45	71.2	33		
AF6FF-20	U1.11 / 16"X12				57	75.5	44		

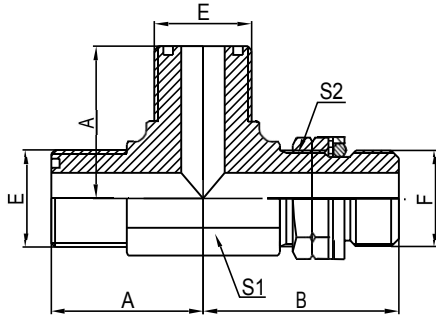

# AFFG-OG

美制ORFS外螺纹O型圈平面密封/  
英管外螺纹O型圈主支三通  
ORFS MALE O-RING/  
BSP MALE O-RING RUN TEE

代号 PART NO.	螺纹 THREADE		尺寸 DIMENSIONS				
	E	F	A	B	S1	S2	
AFFG-04OG	U9/16"X18	G1/4"X19	27	31.3	14	19	
AFFG-04-04-06OG	U9/16"X18	G3/8"X19	28	35.5	17	22	
AFFG-06-06-04OG	U11/16"X16	G1/4"X19	30	33.5	19	19	
AFFG-06OG	U11/16"X16	G3/8"X19	30	36.8	19	22	
AFFG-08-08-06OG	U13/16"X16	G3/8"X19	33	39.5	22	22	
AFFG-08OG	U13/16"X16	G1/2"X14	33	43.2	22	27	
AFFG-10-10-12OG	U1"X14	G3/4"X14	40	49.3	27	32	
AFFG-12OG	U1.3/16"X12	G3/4"X14	40	53.5	27	32	
AFFG-16OG	U1.7/16"X12	G1"X11	45	56	33	41	

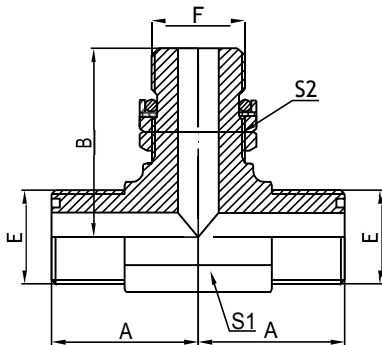

# AFGF-OG

美制ORFS外螺纹O型圈平面密封/  
英管外螺纹O型圈分支三通  
ORFS MALE O-RING/  
BSP MALE O-RING RUN TEE

代号 PART NO.	螺纹 THREADE		尺寸 DIMENSIONS				
	E	F	A	B	S1	S2	
AFGF-04OG	U9/16"X18	G1/4"X19	27	31.3	14	19	
AFGF-04-06-04OG	U9/16"X18	G3/8"X19	28	35.5	17	22	
AFGF-06OG	U11/16"X16	G3/8"X19	30	36.8	19	22	
AFGF-08-06-08OG	U13/16"X16	G3/8"X19	33	39.5	22	22	
AFGF-08OG	U13/16"X16	G1/2"X14	33	43.2	22	27	
AFGF-10-12-10OG	U1"X14	G3/4"X14	40	49.3	27	32	
AFGF-12OG	U1.3/16"X12	G3/4"X14	40	53.5	27	32	
AFGF-16OG	U1.7/16"X12	G1"X11	45	56	33	41	

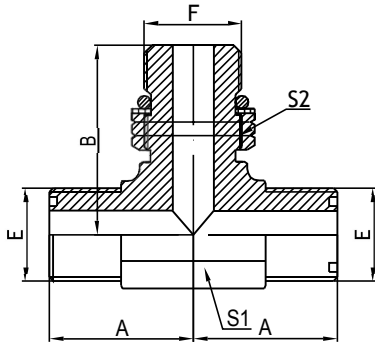

# AFOF-OG

美制ORFS外螺纹O型圈平面密封/  
美制SAE外螺纹带O型圈分支三通  
ORFS MALE O-RING/  
SAE O-RING BOSS BRANCH TEE

代号 PART NO.	螺纹 THREADS		尺寸 DIMENSIONS				
	E	F	A	B	S1	S2	
AFOF-04OG	U9/16"X18	U7/16"X20	27	30.3	14	17	
AFOF-04-06-04OG	U9/16"X18	U9/16"X18	27	32	14	19	
AFOF-06OG	U11/16"X16	U9/16"X18	30	35.5	19	19	
AFOF-06-08-06OG	U11/16"X16	U3/4"X16	30	38	19	24	
AFOF-08OG	U13/16"X16	U3/4"X16	33	40.5	22	24	
AFOF-08-10-08OG	U13/16"X16	U7/8"X14	33	45.3	22	27	
AFOF-08-12-08OG	U13/16"X16	U1.1/16"X12	33	54	24	32	
AFOF-10OG	U1"X14	U7/8"X14	40	50.8	27	27	
AFOF-10-12-10OG	U1"X14	U1.1/16"X12	40	52	27	32	
AFOF-12OG	U1.3/16"X12	U1.1/16"X12	40	55.3	27	32	
AFOF-16OG	U1.7/16"X12	U1.5/16"X12	45	59.3	33	41	
AFOF-20OG	U1.11/16"X12	U1.5/8"X12	57	60.5	44	50	



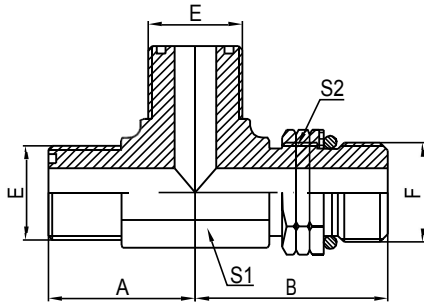

# AFFO-OG

美制ORFS外螺纹O型圈平面密封/  
美制SAE外螺纹带O型圈主支三通  
ORFS MALE O-RING/  
SAE O-RING BOSS RUN TEE

代号 PART NO.	螺纹 THREADE		尺寸 DIMENSIONS				
	E	F	A	B	S1	S2	
AFFO-04OG	U9/16"X18	U7/16"X20	27	30	14	17	
AFFO-04-04-06OG	U9/16"X18	U9/16"X18	27	32	14	19	
AFFO-06OG	U11/16"X16	U9/16"X18	30	35.5	19	19	
AFFO-06-06-08OG	U11/16"X16	U3/4"X16	30	38	19	24	
AFFO-08-08-06OG	U13/16"X16	U9/16"X18	33	37.5	22	19	
AFFO-08OG	U13/16"X16	U3/4"X16	33	40.5	22	24	
AFFO-08-08-10OG	U13/16"X16	U7/8"X14	33	45.3	22	27	
AFFO-08-08-12OG	U13/16"X16	U1.1/16"X12	33	54	24	32	
AFFO-10OG	U1"X14	U7/8"X14	40	50.8	27	27	
AFFO-10-10-12OG	U1"X14	U1.1/16"X12	40	52	27	32	
AFFO-12OG	U1.3/16"X12	U1.1/16"X12	40	55.3	27	32	
AFFO-16-16-12OG	U1.7/16"X12	U1.1/16"X12	45	59.5	33	32	
AFFO-16OG	U1.7/16"X12	U1.5/16"X12	45	59.3	33	41	
AFFO-20OG	U1.11/16"X12	U1.5/8"X12	57	60.5	44	50	

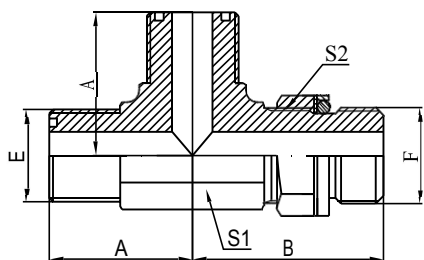

## AFFH-OG

美制ORFS外螺纹O型圈平面密封/  
公制外螺纹可调向柱端主支三通  
ORFS MALE O-RING/ METRIC  
MALE ADJUSTABLE STUD END RUN TEE

代号 PART NO.	螺纹 THREADS		O型圈 O RING		尺寸 DIMENSIONS				
	E	F	F端		A	B	S1	S2	
AFFH-04-04-14OG	U9/16"X18	M14x1.5	11.3x2.4		27	33.5	14	19	
AFFH-06-06-16OG	U11/16"X16	M16x1.5	13.3x2.4		30	38	19	22	
AFFH-08-08-22OG	U13/16"X16	M22x1.5	19.3x2.4		33	44.5	24	27	
AFFH-10-10-22OG	U1"X14	M22x1.5	19.3x2.4		40	48	27	27	
AFFH-12-12-27OG	U1.3/16"X12	M27x2	23.5x3		40	50	27	32	

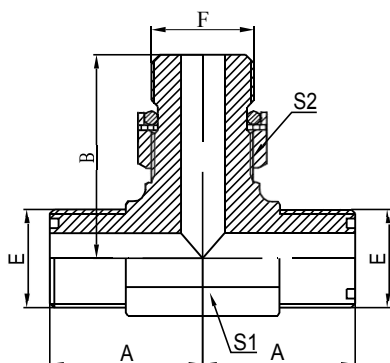

## AFHF-OG

美制ORFS外螺纹O型圈平面密封/  
公制外螺纹可调向柱端分支三通  
ORFS MALE O-RING/ METRIC  
MALE ADJUSTABLE STUD END BRANCH TEE

代号 PART NO.	螺纹 THREADS		O型圈 O RING		尺寸 DIMENSIONS				
	E	F	F端		A	B	S1	S2	
AFHF-04-14-04OG	U9/16"X18	M14x1.5	11.3x2.4		27	23	14	19	
AFHF-06-16-06OG	U11/16"X16	M16x1.5	13.3x2.4		30	27	19	22	
AFHF-08-22-08OG	U13/16"X16	M22x1.5	19.3x2.4		33	31	24	27	
AFHF-10-22-10OG	U1"X14	M22x1.5	19.3x2.4		40	36.5	27	27	
AFHF-12-27-12OG	U1.3/16"X12	M27x2	23.5x3		40	40.5	27	32	

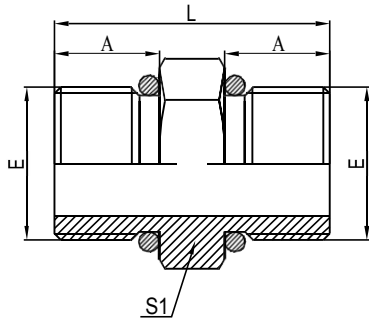

# 1G

英管外螺纹O型圈  
BSP MALE O-RING

代号 PART NO.	螺纹 THREADE				尺寸 DIMENSIONS				
	E				A		S1		L
1G-02	G1/8"x28				9		14		24
1G-04	G1/4"x19				12		19		30
1G-06	G3/8"x19				13.5		22		35
1G-08	G1/2"x14				16		27		41
1G-12	G3/4"x14				18.5		32		47
1G-16	G1"x11				20.5		41		53
1G-20	G1.1/4"x12				20.5		50		55
1G-24	G1.1/2"x11				23		55		62

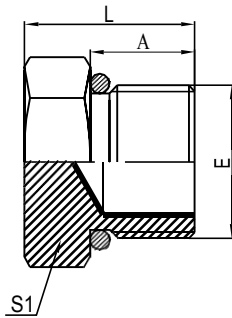

# 4G

英管外螺纹O型圈堵头  
BSP MALE O-RING PLUG

代号 PART NO.	螺纹 THREADE				尺寸 DIMENSIONS				
	E				A		S1		L
4G-04	G1/4"x19				12		19		18
4G-06	G3/8"x19				13.5		22		21
4G-08	G1/2"x14				16		27		25
4G-12	G3/4"x14				18.5		32		28
4G-16	G1"x11				20.5		41		32

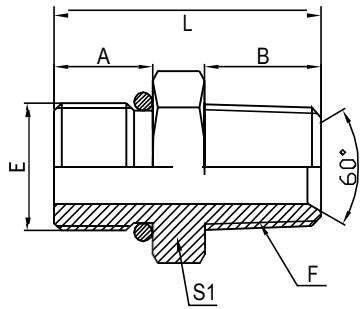

# 1GT

英管外螺纹O型圈/ 英锥管外螺纹  
BSP MALE O-RING/BSPT MALE

代号 PART NO.	螺纹 THREADE		尺寸 DIMENSIONS				
	E	F	A	B	S1	L	
1GT-04-04	G1/4"X19	ZG1/4"X19	12	14	19	32	
1GT-06-04	G3/8"X19	ZG1/4"X19	13.5	14	22	35.5	
1GT-06-06	G3/8"X19	ZG3/8"X19	13.5	14	22	35.5	
1GT-08-06	G1/2"X14	ZG3/8"X19	16	14	27	38	
1GT-08-08	G1/2"X14	ZG1/2"X14	16	19	27	43	
1GT-12-08	G3/4"X14	ZG1/2"X14	18.5	19	32	48	
1GT-12-12	G3/4"X14	ZG3/4"X14	18.5	19.5	32	48	
1GT-16-16	G1"X11	ZG1"X11	20.5	24	41	55	
1GT-20-20	G1.1/4"X11	ZG1.1/4"X11	20.5	25	50	62	
1GT-24-24	G1.1/2"X11	ZG1.1/2"X11	23	25	55	65	
1GT-32-32	G2"X11	ZG2"X11	25.5	29	70	72	

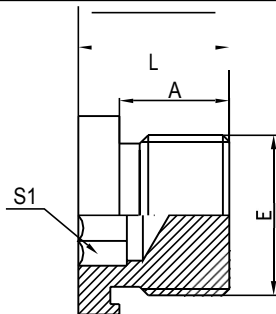

# 4HN

公制外螺纹轻系列内六角堵头  
METRIC MALE L-SERIES  
HOLLOW HEX PLUG

代号 PART NO.	螺纹 THREADE		尺寸 DIMENSIONS				
	E		A		S1	L	
4HN-10	M10x1		11		5	14	
4HN-12	M12x1.5		11		6	14	
4HN-14	M14x1.5		11		6	14	
4HN-16	M16x1.5		11		8	13.5	
4HN-18	M18x1.5		11		8	14.5	
4HN-22	M22x1.5		12		10	15	
4HN-27	M27x2		13		12	16	

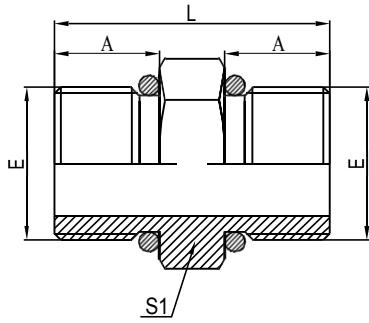

# 1H

公制外螺纹轻系列  
METRIC MALE L-SERIES

代号 PART NO.	螺纹 THREADE				尺寸 DIMENSIONS				
	E				A		S1		L
1H-10	M10x1				11		14		28
1H-12	M12x1.5				11		17		28
1H-14	M14x1.5				11		19		28
1H-16	M16x1.5				11		22		30
1H-18	M18x1.5				11		24		30
1H-22	M22x1.5				12		27		33
1H-27	M27x2				13		32		35

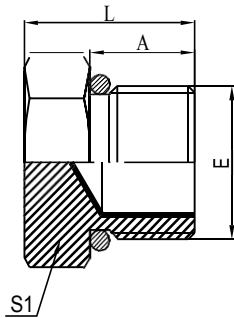

# 4H

公制外螺纹轻系列堵头  
METRIC MALE L-SERIES PLUG

代号 PART NO.	螺纹 THREADE				尺寸 DIMENSIONS				
	E				A		S1		L
4H-10	M10x1				11		14		17
4H-12	M12x1.5				11		17		17
4H-14	M14x1.5				11		19		17
4H-16	M16x1.5				11		22		19
4H-18	M18x1.5				11		24		19
4H-22	M22x1.5				12		27		21
4H-27	M27x2				13		32		22

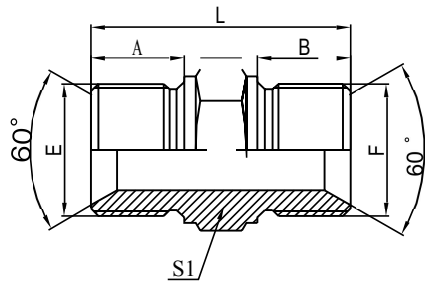

# 1M

公制外螺纹60°内锥或六角端面组合垫密封  
 METRIC MALE DOUBLE FOR 60°  
 CONE SEAT BONDED SEAL

代号 PART NO.	螺纹 THREADE		尺寸 DIMENSIONS				
	E	F		A	B	S1	L
1M-12	M12x1.5	M12x1.5		10	10	17	30
1M-12-14	M12x1.5	M14x1.5		10	11	19	31
1M-14	M14x1.5	M14x1.5		11	11	19	32
1M-14-16	M14x1.5	M16x1.5		11	12	22	35
1M-16	M16x1.5	M16x1.5		12	12	22	36
1M-16-18	M16x1.5	M18x1.5		12	12	24	36
1M-18	M18x1.5	M18x1.5		12	12	24	36
1M-18-22	M18x1.5	M22x1.5		12	14	27	38
1M-22	M22x1.5	M22x1.5		14	14	27	42

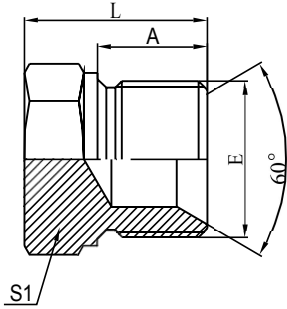

## 4M

公制外螺纹60°内锥或六角端面组合垫密封堵头  
METRIC MALE DOUBLE FOR 60°  
CONE SEAT BONDED SEAL PLUG

代号 PART NO.	螺纹 THREADE		尺寸 DIMENSIONS				
	E	F	A		S1	L	
4M-12	M12x1.5	M12x1.5	10		17	18	
4M-14	M14x1.5	M14x1.5	11		19	19	
4M-16	M16x1.5	M16x1.5	12		22	21	
4M-18	M18x1.5	M18x1.5	12		24	21	
4M-22	M22x1.5	M22x1.5	14		27	24	

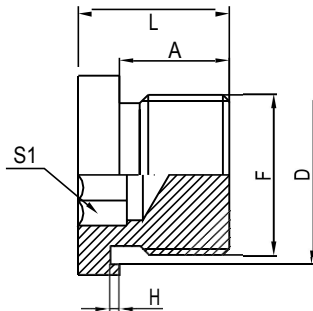

## 4MN-WD

公制外螺纹胶垫密封内六角堵头  
METRIC MALE CAPTIVE  
SEAL HOLLOW HEX PLUG

代号 PART NO.	螺纹 THREADE		尺寸 DIMENSIONS				
	E		A	D	H	S1	L
4MN-12WD	M12x1.5		10	14.2	1.2	6	15
4MN-14WD	M14x1.5		11	16.3	1.2	6	16
4MN-16WD	M16x1.5		12	18.7	1.2	8	17
4MN-18WD	M18x1.5		12	20.7	1.2	8	17
4MN-22WD	M22x1.5		14	24.1	1.2	10	19

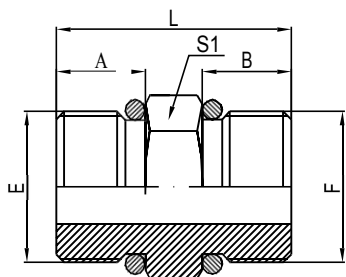

# 10

美制SAE外螺纹带O型圈  
SAE O-RING BOSS

代号 PART NO.	螺纹 THREADE		尺寸 DIMENSIONS				
	E	F	A	B	S1	L	
10-04	U7/16"X20	U7/16"X20	10	10	14	26	
10-04-06	U7/16"X20	U9/16"X18	10	12	17	28	
10-06	U9/16"X18	U9/16"X18	12	12	17	30	
10-06-08	U9/16"X18	U3/4"X16	12	12	22	31	
10-08	U3/4"X16	U3/4"X16	12	12	22	31	
10-08-12	U3/4"X16	U1.1/16"X12	12	16	32	34	
10-10	U7/8"X14	U7/8"X14	13.5	13.5	27	35	
10-12	U1.1/16"X12	U1.1/16"X12	16	16	32	41	
10-16	U1.5/16"X12	U1.5/16"X12	17	17	41	44	
10-20	U1.5/8"X12	U1.5/8"X12	18	18	50	48.5	
10-24	U1.7/8"X12	U1.7/8"X12	18.5	18.5	55	55	

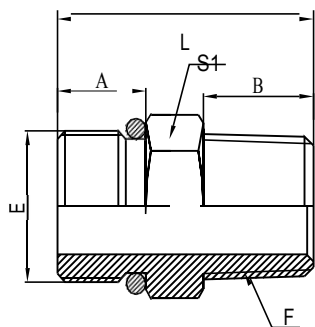

# 10T

美制SAE外螺纹带O型圈/ 英锥管外螺纹  
SAE O-RING BOSS/BSPT MALE

代号 PART NO.	螺纹 THREADE		尺寸 DIMENSIONS				
	E	F	A	B	S1	L	
10T-04-04	U7/16"X20	ZG1/4"-19	10	14	14	30	
10T-04-06	U7/16"X20	ZG3/8"-19	10	14	17	30	
10T-06-06	U9/16"X18	ZG3/8"-19	12	14	17	33	
10T-06-08	U9/16"X18	ZG1/2"-14	12	19	22	38	
10T-08-08	U3/4"X16	ZG1/2"-14	12	19	22	38.5	
10T-08-12	U3/4"X16	ZG3/4"-14	12	29	32	39	
10T-12-12	U1.1/16"X12	ZG3/4"-14	16	29	32	53	
10T-16-16	U1.5/16"X12	ZG1"-11	17	29	41	55	
10T-20-20	U1.5/8"X12	ZG1.1/4"-11	18	29	50	58	
10T-24-24	U1.7/8"X12	ZG1.1/2"-11	18.5	29	55	60	



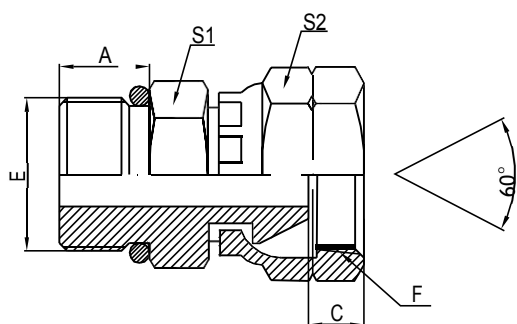

# 2OU

SAE外螺纹带O型圈/  
美制NPSM内螺纹60°外锥  
SAE O-RING BOSS /  
NPSM FEMALE 60° CONE

代号 PART NO.	螺纹 THREADE		尺寸 DIMENSIONS				
	E	F	A	C	S1	S2	
2OU-04	U7/16"X20	Z1/4"X18	10	5.5	14	19	
2OU-04-06	U7/16"X20	Z3/8"X18	10	6.5	17	22	
2OU-06	U9/16"X18	Z3/8"X18	12	6.5	19	22	
2OU-06-08	U9/16"X18	Z1/2"X14	12	8	22	27	
2OU-08	U3/4"X16	Z1/2"X14	12	8	22	27	
2OU-08-06	U3/4"X16	Z3/8"X18	12	6.5	22	22	
2OU-10-08	U7/8"X14	Z1/2"X14	13.5	8	27	27	
2OU-12-08	U1.1/16"X12	Z1/2"X14	16	8	32	27	
2OU-12	U1.1/16"X12	Z3/4"X14	16	11.5	32	32	
2OU-12-16	U1.1/16"X12	Z1"X11.5	16	11.5	36	41	
2OU-16	U1.5/16"X12	Z1"X11.5	17	11.5	41	41	
2OU-20	U1.5/8"X12	Z1.1/4"X11.5	18	12	50	50	
2OU-24	U1.7/8"X12	Z1.1/2"X11.5	18.5	13	55	55	

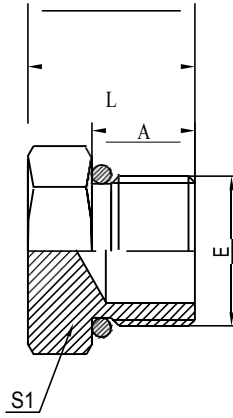

# 40

美制SAE外螺纹带O型圈堵头  
SAE O-RING BOSS PLUG

代号 PART NO.	螺纹 THREADE				尺寸 DIMENSIONS				
	E				A		S1		L
40-04	U7/16"X20				10		14		16
40-05	U1/2"X20				10		17		16
40-06	U9/16"X18				12		17		18
40-08	U3/4"X16				12		22		20
40-10	U7/8"X14				13.5		27		23
40-12	U1.1/16"X12				16		32		26
40-16	U1.5/16"X12				17		41		28
40-20	U1.5/8"X12				18		50		32
40-24	U1.7/8"X12				18.5		55		35
40-32	U2.1/2"X12				22		70		40

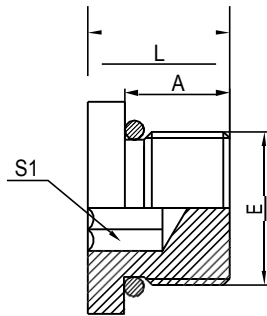

# 40N

美制SAE外螺纹带O型圈内六角堵头  
SAE O-RING BOSS HOLLOW HEX PLUG

代号 PART NO.	螺纹 THREADE				尺寸 DIMENSIONS				
	E				A		S1		L
40N-04	U7/16"X20				10		5		12
40N-05	U1/2"X20				10		5		12
40N-06	U9/16"X18				12		6		15
40N-08	U3/4"X16				12		8		15
40N-10	U7/8"X14				13.5		10		16.5
40N-12	U1.1/16"X12				16		14		20
40N-16	U1.5/16"X12				17		16		21
40N-20	U1.5/8"X12				18		19		22

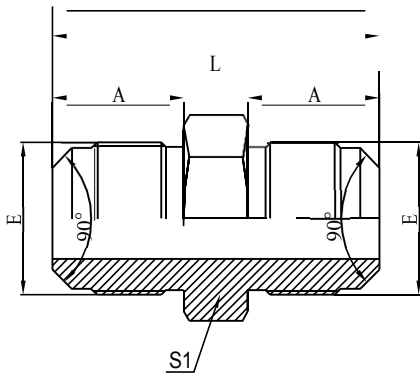

# 1P

美制SAE外螺纹90°外锥  
SAE MALE 90° CONE

代号 PART NO.	螺纹 THREADE				尺寸 DIMENSIONS			
	E				A	S1		L
1P-04	U7/16"X20				13	14		32
1P-05	U1/2"X20				14	14		34
1P-06	U5/8"X18				16	17		38
1P-08	U3/4"X16				19	22		46
1P-10	U7/8"X14				22.5	24		52.5
1P-12	U1.1/16"X12				25.5	30		60.5

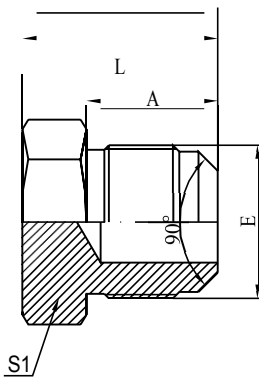

# 4P

美制SAE外螺纹90°外锥堵头  
SAE MALE 90° CONE PLUG

代号 PART NO.	螺纹 THREADE				尺寸 DIMENSIONS			
	E				A	S1		L
4P-04	U7/16"X20				13	14		19
4P-05	U1/2"X20				14	14		20
4P-06	U5/8"X18				16	17		22
4P-08	U3/4"X16				19	22		27
4P-10	U7/8"X14				22.5	24		30
4P-12	U1.1/16"X12				25.5	30		35

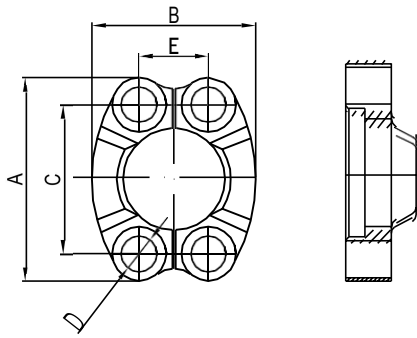

# FL

轻系列对开法兰夹  
L-SERIES SPLIT FLANGE CLAMPS

代号 PART NO.	法兰型号 FLANGE SIZE	螺栓 BOLT	尺寸 DIMENSIONS				
			A	B	C	D	E
FL-08	1/2"	M8x25	54	46	38.1	9	17.5
FL-12	3/4"	M10x30	65.1	52	47.6	11	22.2
FL-16	1"	M10x30	69.8	59	52.4	11	26.2
FL-20	1.1/4"	M10x30	79.4	73	58.7	11	30.2
FL-24	1.1/2"	M12x35	93.7	83	69.8	13.5	35.7
FL-32	2"	M12x35	101.6	97	77.8	13.5	42.9
FL-40	2.1/4"	M12x40	114	108	89	13.5	50.8
FL-48	3"	M16x50	135	130.6	106.4	16.7	62

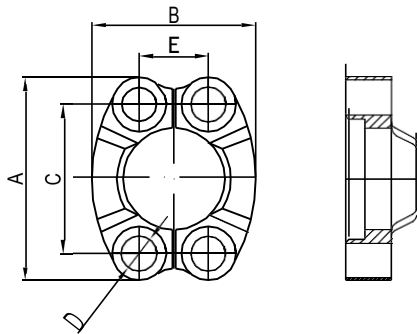

# FS

重系列对开法兰夹  
S-SERIES SPLIT FLANGE CLAMPS

代号 PART NO.	法兰型号 FLANGE SIZE	螺栓 BOLT	尺寸 DIMENSIONS				
			A	B	C	D	E
FS-08	1/2"	M8x30	56.3	47	40.5	9	18.2
FS-12	3/4"	M10x35	71.4	60	50.8	11	23.8
FS-16	1"	M12x45	80.9	70	57.1	13	27.8
FS-20	1.1/4"	M14x30	95.2	77	66.7	15	31.8
FS-24	1.1/2"	M16x55	112.7	95	79.5	17	36.5
FS-32	2"	M20x70	133.3	114	96.8	21	44.5

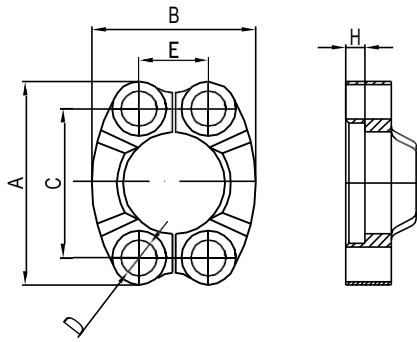

# FL-W

轻系列整体法兰夹  
L-SERIES WHOLE FLANGE CLAMPS

代号 PART NO.	法兰型号 FLANGE SIZE	螺栓 BOLT	尺寸 DIMENSIONS					
			A	B	C	D	E	H
FL-08W	1/2"	M8x25	54	46	38.1	9	17.5	6.2
FL-12W	3/4"	M10x30	65.1	52	47.6	11	22.2	6.2
FL-16W	1"	M10x30	69.8	59	52.4	11	26.2	7.5
FL-20W	1.1/4"	M10x30	79.4	73	58.7	11	30.2	7.5
FL-24W	1.1/2"	M12x35	93.7	83	69.8	13.5	35.7	7.5
FL-32W	2"	M12x35	101.6	97	77.8	13.5	42.9	9
FL-40W	2.1/4"	M12x40	114	108	89	13.5	50.8	9
FL-48W	3"	M16x50	135	130.6	106.4	16.7	62	9

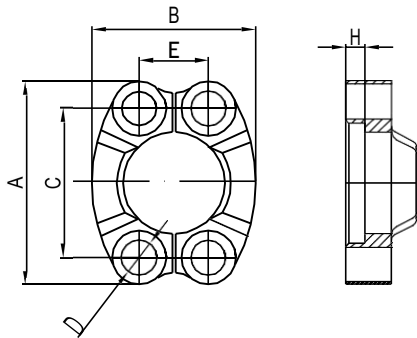

# FS-W

重系列整体法兰夹  
S-SERIES WHOLE FLANGE CLAMPS

代号 PART NO.	法兰型号 FLANGE SIZE	螺栓 BOLT	尺寸 DIMENSIONS					
			A	B	C	D	E	H
FS-08W	1/2"	M8x30	56.3	47	40.5	9	18.2	7.2
FS-12W	3/4"	M10x35	71.4	60	50.8	11	23.8	8.2
FS-16W	1"	M12x45	80.9	70	57.1	13	27.8	9
FS-20W	1.1/4"	M14x30	95.2	77	66.7	15	31.8	9.8
FS-24W	1.1/2"	M16x55	112.7	95	79.5	17	36.5	12
FS-32W	2"	M20x70	133.3	114	96.8	21	44.5	12

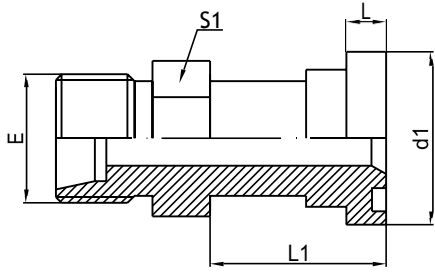

# 1CFL

公制螺纹卡套式/轻系列法兰  
METRIC MALE BITE TYPE/  
L-SERIES FLANGE

代号 PART NO.	螺纹 THREADE	法兰型号 FLANGE SIZE	管子外径 D TUBE O.D.	尺寸 DIMENSIONS				
	E			L	L1	d1	S1	
1CFL-22-08	M22x1.5	1/2"	15	7	35	30.2	24	
1CFL-26-12	M26x1.5	3/4"	18	7	46	38.1	30	
1CFL-30-12	M30x2	3/4"	22	7	46	38.1	32	
1CFL-36-16	M36x2	1"	28	8.2	50	44.4	41	
1CFL-45-20	M45x2	1.1/4"	35	8.2	66	50.8	41	
1CFL-52-24	M52x2	1.1/2"	42	8.2	70	60.3	46	

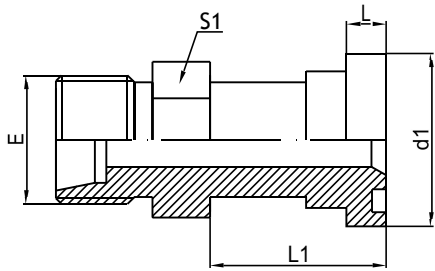

# 1DFL

公制螺纹卡套式/轻系列法兰  
METRIC MALE BITE TYPE/  
L-SERIES FLANGE

代号 PART NO.	螺纹 THREADE	法兰型号 FLANGE SIZE	管子外径 D TUBE O.D.	尺寸 DIMENSIONS				
	E			L	L1	d1	S1	
1DFL-24-08	M24x1.5	1/2"	16	7	35	30.2	24	
1DFL-24-12	M24x1.5	3/4"	20	7	46	38.1	27	
1DFL-30-12	M30x2	3/4"	20	7	46	38.1	30	
1DFL-36-12	M36x2	3/4"	25	7	46	38.1	30	
1DFL-42-16	M42x2	1"	30	8.2	50	44.4	36	
1DFL-36-20	M36x2	1.1/4"	25	8.2	66	50.8	41	
1DFL-42-20	M42x2	1.1/4"	30	8.2	66	50.8	41	
1DFL-52-20	M52x2	1.1/4"	38	8.2	66	50.8	46	
1DFL-52-24	M52x2	1.1/2"	38	8.2	70	60.3	46	

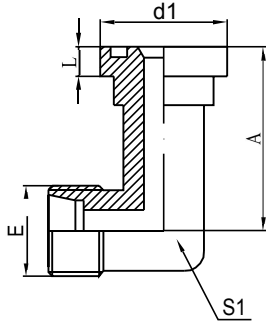

# 1CFL9

90° 公制螺纹卡套式/ 轻系列法兰  
90° METRIC MALE BITE TYPE/  
L-SERIES FLANGE

代号 PART NO.	螺纹 THREADE	法兰型号 FLANGE SIZE	管子外径 D TUBE O.D.	尺寸 DIMENSIONS				
	E			L	A	d1	S1	
1CFL9-22-08	M22x1.5	1/2"	15	7	36	30.2	22	
1CFL9-26-12	M26x1.5	3/4"	18	7	42	38.1	27	
1CFL9-30-12	M30x2	3/4"	22	7	42	38.1	27	
1CFL9-36-16	M36x2	1"	28	8.2	45	44.4	33	
1CFL9-45-20	M45x2	1.1/4"	35	8.2	50	50.8	44	
1CFL9-52-24	M52x2	1.1/2"	42	8.2	55	60.3	50	

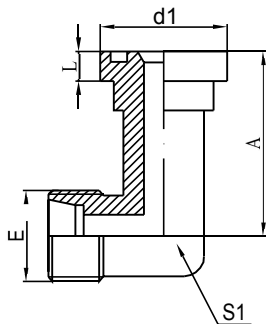

# 1DFL9

90° 公制螺纹卡套式/ 轻系列法兰  
90° METRIC MALE BITE TYPE/  
L-SERIES FLANGE

代号 PART NO.	螺纹 THREADE	法兰型号 FLANGE SIZE	管子外径 D TUBE O.D.	尺寸 DIMENSIONS				
	E			L	A	d1	S1	
1DFL9-24-08	M24x1.5	1/2"	16	7	36	30.2	27	
1DFL9-30-12	M30x2	3/4"	20	7	42	38.1	27	
1DFL9-36-12	M36x2	3/4"	25	7	42	38.1	33	
1DFL9-42-16	M42x2	1"	30	8.2	45	44.4	44	
1DFL9-36-20	M36x2	1.1/4"	25	8.2	50	50.8	44	
1DFL9-42-20	M42x2	1.1/4"	30	8.2	50	50.8	44	
1DFL9-52-20	M52x2	1.1/4"	38	8.2	50	50.8	50	
1DFL9-52-24	M52x2	1.1/2"	38	8.2	55	60.3	50	

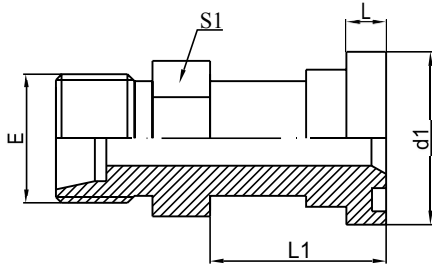

# 1DFS

公制螺纹卡套式/重系列法兰  
METRIC MALE BITE TYPE/  
S-SERIES FLANGE

代号 PART NO.	螺纹 THREADE	法兰型号 FLANGE SIZE	管子外径 D TUBE O.D.	尺寸 DIMENSIONS				
	E			L	L1	d1	S1	
1DFS-24-08	M24x1.5	1/2"	16	7.9	37	31.7	24	
1DFS-24-12	M24x1.5	3/4"	16	8.9	51	41.3	30	
1DFS-30-12	M30x2	3/4"	20	8.9	51	41.3	30	
1DFS-36-12	M36x2	3/4"	25	8.9	51	41.3	30	
1DFS-36-16	M36x2	1"	25	9.6	53	47.6	36	
1DFS-42-16	M42x2	1"	30	9.6	53	47.6	36	
1DFS-42-20	M42x2	1.1/4"	30	10.4	70	54	41	
1DFS-52-20	M52x2	1.1/4"	38	10.4	70	54	46	
1DFS-52-24	M52x2	1.1/2"	38	12.7	80	63.5	46	

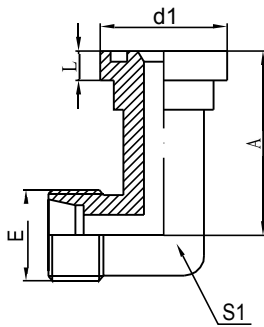

# 1DFS9

90° 公制螺纹卡套式/重系列法兰  
90° METRIC MALE BITE TYPE/  
S-SERIES FLANGE

代号 PART NO.	螺纹 THREADE	法兰型号 FLANGE SIZE	管子外径 D TUBE O.D.	尺寸 DIMENSIONS				
	E			L	A	d1	S1	
1DFS9-24-08	M24x1.5	1/2"	16	7.9	39	31.7	24	
1DFS9-24-12	M24x1.5	3/4"	16	8.9	48	41.3	30	
1DFS9-30-12	M30x2	3/4"	20	8.9	48	41.3	30	
1DFS9-36-12	M36x2	3/4"	25	8.9	48	41.3	36	
1DFS9-36-16	M36x2	1"	25	9.6	60	47.6	41	
1DFS9-42-16	M42x2	1"	30	9.6	60	47.6	41	
1DFS9-42-20	M42x2	1.1/4"	30	10.4	68	54	46	
1DFS9-52-20	M52x2	1.1/4"	38	10.4	68	54	46	
1DFS9-52-24	M52x2	1.1/2"	38	12.7	76	63.5	46	



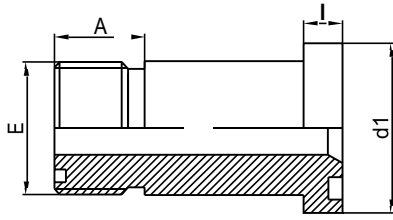

# 1FFL

美制ORFS外螺纹O型圈平面  
密封/轻系列法兰  
ORFS MALE O-RING/  
L-SERIES FLANGE

代号 PART NO.	螺纹 THREADE	法兰型号 FLANGE SIZE	尺寸 DIMENSIONS				
	E		I	d1	A		
1FFL-12	U1.3/16"x12	3/4"	7	38.1	17		
1FFL-16	U1.7/16"x12	1"	8.2	44.4	18.5		
1FFL-20	U1.11/16"x12	1.1/4"	8.2	50.8	19.5		

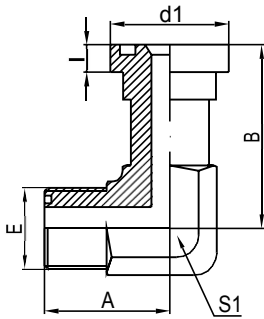

# 1FFL9

90° 美制ORFS外螺纹O型圈平面  
密封/轻系列法兰  
90° ORFS MALE O-RING/  
L-SERIES FLANGE

代号 PART NO.	螺纹 THREADE	法兰型号 FLANGE SIZE	尺寸 DIMENSIONS				
	E		I	d1	A	B	S1
1FFL9-12	U1.3/16"x12	3/4"	7	38.1	43	54.1	27
1FFL9-16	U1.7/16"x12	1"	8.2	44.4	59	60.2	44
1FFL9-20	U1.11/16"x12	1.1/4"	8.2	50.8	59	66.5	44

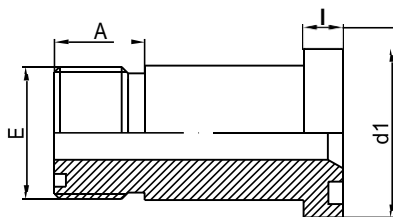

# 1FFS

美制ORFS外螺纹O型圈平面  
密封/重系列法兰  
ORFS MALE O-RING/  
S-SERIES FLANGE

代号 PART NO.	螺纹 THREADE	法兰型号 FLANGE SIZE	尺寸 DIMENSIONS				
	E		I	d1	A		
1FFS-12	U1.3/16"x12	3/4"	8.9	41.3	17		
1FFS-16	U1.7/16"x12	1"	9.6	47.6	18.5		
1FFS-20	U1.11/16"x12	1.1/4"	10.4	54	19.5		

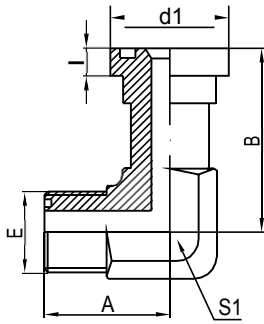

# 1FFS9

90° 美制ORFS外螺纹O型圈平面  
密封/重系列法兰  
90° ORFS MALE O-RING/  
S-SERIES FLANGE

代号 PART NO.	螺纹 THREADE	法兰型号 FLANGE SIZE	尺寸 DIMENSIONS				
	E		I	d1	A	B	S1
1FFS9-12	U1.3/16"x12	3/4"	8.9	41.3	40	54.1	27
1FFS9-16	U1.7/16"x12	1"	9.6	47.6	49	60.2	33
1FFS9-20	U1.11/16"x12	1.1/4"	10.4	54	57	66.5	44

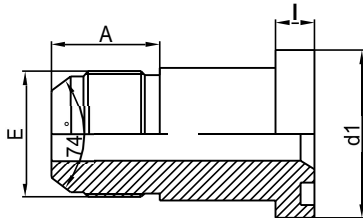

# 1JFL

美制JIC外螺纹74°外锥/轻系列法兰  
JIC MALE 74° CONE/L-SERIES FLANGE

代号 PART NO.	螺纹 THREADE	法兰型号 FLANGE SIZE	尺寸 DIMENSIONS				
	E		I	d1	A		
1JFL-08	U3/4"X16	1/2"	7	30.2	16.7		
1JFL-08-12	U3/4"X16	3/4"	7	38.1	16.7		
1JFL-10-08	U7/8"X14	1/2"	7	30.2	19.5		
1JFL-10-12	U7/8"X14	3/4"	7	38.1	19.5		
1JFL-12-08	U1.1/16"X12	1/2"	7	30.2	22		
1JFL-12	U1.1/16"X12	3/4"	7	38.1	22		
1JFL-12-16	U1.1/16"X12	1"	8.2	44.4	22		
1JFL-16-12	U1.5/16"X12	3/4"	7	38.1	23		
1JFL-16	U1.5/16"X12	1"	8.2	44.4	23		
1JFL-16-20	U1.5/16"X12	1.1/4"	8.2	50.8	23		
1JFL-20-16	U1.5/8"X12	1"	8.2	44.4	24.5		
1JFL-20	U1.5/8"X12	1.1/4"	8.2	50.8	24.5		
1JFL-20-24	U1.5/8"X12	1.1/2"	8.2	60.3	24.5		
1JFL-24-20	U1.7/8"X12	1.1/4"	8.2	50.8	27.5		
1JFL-24	U1.7/8"X12	1.1/2"	8.2	60.3	27.5		
1JFL-24-32	U1.7/8"X12	2"	9.8	71.4	27.5		
1JFL-32	U2.1/2"X12	2"	9.8	71.4	34		

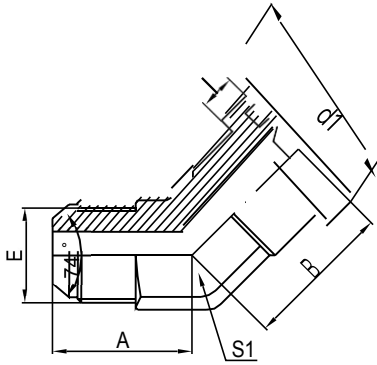

# 1JFL4

45° 美制JIC外螺纹74° 外锥/轻系列法兰  
 45° JIC MALE 74° CONE/L-ERIES FLANGE

代号 PART NO.	螺纹 THREADE	法兰型号 FLANGE SIZE	尺寸 DIMENSIONS				
	E		I	d1	A	B	S1
1JFL4-08	U3/4"X16	1/2"	7	30.2	25	37	19
1JFL4-10-08	U7/8"X14	1/2"	7	30.2	27	37	22
1JFL4-10-12	U7/8"X14	3/4"	7	38.1	33	40.1	27
1JFL4-12	U1.1/16"X12	3/4"	7	38.1	33	40.1	27
1JFL4-12-16	U1.1/16"X12	1"	8.2	44.4	37	47	33
1JFL4-16	U1.5/16"X12	1"	8.2	44.4	37	47	33
1JFL4-16-12	U1.5/16"X12	3/4"	7	38.1	37	42	33
1JFL4-16-20	U1.5/16"X12	1.1/4"	8.2	50.8	40	51.8	44
1JFL4-20	U1.5/8"X12	1.1/4"	8.2	50.8	40	51.8	44
1JFL4-20-16	U1.5/8"X12	1"	8.2	44.4	40	51	44
1JFL4-20-24	U1.5/8"X12	1.1/2"	8.2	60.3	47	60.5	53
1JFL4-24-20	U1.7/8"X12	1.1/4"	8.2	50.8	47	54	53
1JFL4-24	U1.7/8"X12	1.1/2"	8.2	60.3	47	60.5	53
1JFL4-32	U2.1/2"X12	2"	9.8	71.4	55	76.2	65

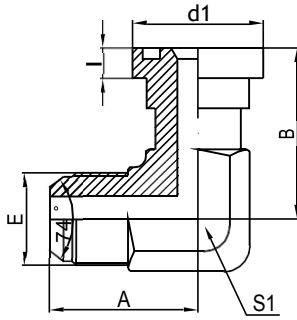

# 1JFL9

90° 美制JIC外螺纹74° 外锥/轻系列法兰  
90° JIC MALE 74° CONE/L-ERIES FLANGE

代号 PART NO.	螺纹 THREADE E	法兰型号 FLANGE SIZE	尺寸 DIMENSIONS				
			I	d1	A	B	S1
1JFL9-08	U3/4"X16	1/2"	7	30.2	33	44	19
1JFL9-10-08	U7/8"X14	1/2"	7	30.2	37	44	22
1JFL9-10-12	U7/8"X14	3/4"	7	38.1	43	54.1	27
1JFL9-12	U1.1/16"X12	3/4"	7	38.1	40	40.1	27
1JFL9-12-16	U1.1/16"X12	1"	8.2	44.4	49	60.2	33
1JFL9-16	U1.5/16"X12	1"	8.2	44.4	49	60.2	33
1JFL9-16-12	U1.5/16"X12	3/4"	7	38.1	49	58	33
1JFL9-16-20	U1.5/16"X12	1.1/4"	8.2	50.8	57	66.5	44
1JFL9-20	U1.5/8"X12	1.1/4"	8.2	50.8	57	66.5	44
1JFL9-20-16	U1.5/8"X12	1"	8.2	44.4	57	65	44
1JFL9-20-24	U1.5/8"X12	1.1/2"	8.2	60.3	57	79.3	48
1JFL9-24-20	U1.7/8"X12	1.1/4"	8.2	50.8	57	75.5	48
1JFL9-24	U1.7/8"X12	1.1/2"	8.2	60.3	57	79.3	48
1JFL9-32	U2.1/2"X12	2"	9.8	71.4	66	108	65

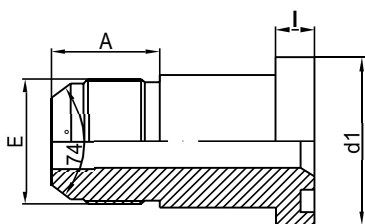

# 1JFS

美制JIC外螺纹74°外锥/重系列法兰  
JIC MALE 74° CONE/S-ERIES FLANGE

代号 PART NO.	螺纹 THREADE E	法兰型号 FLANGE SIZE	尺寸 DIMENSIONS				
			I	d1	A		
1JFS-08	U3/4"X16	1/2"	7.9	31.7	16.7		
1JFS-10-08	U7/8"X14	1/2"	7.9	31.7	19.5		
1JFS-10-12	U7/8"X14	3/4"	8.9	41.3	22		
1JFS-12	U1.1/16"X12	3/4"	8.9	41.3	22		
1JFS-12-16	U1.1/16"X12	1"	8.9	41.3	22		
1JFS-16	U1.5/16"X12	1"	9.6	47.6	23		
1JFS-16-12	U1.5/16"X12	3/4"	9.6	47.6	23		
1JFS-16-20	U1.5/16"X12	1.1/4"	9.6	47.6	23		
1JFS-20	U1.5/8"X12	1.1/4"	10.4	54	24.5		
1JFS-20-16	U1.5/8"X12	1"	10.4	54	24.5		
1JFS-20-24	U1.5/8"X12	1.1/2"	10.4	54	24.5		
1JFS-24-20	U1.7/8"X12	1.1/4"	12.7	63.5	27.5		
1JFS-24	U1.7/8"X12	1.1/2"	12.7	63.5	27.5		

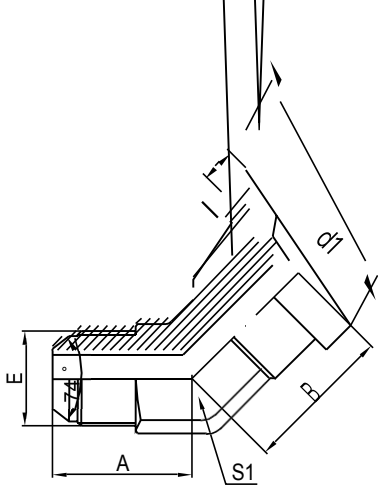

# 1JFS4

45° 美制JIC外螺纹74° 外锥/重系列法兰  
 45° JIC MALE 74° CONE/S-ERIES FLANGE

代号 PART NO.	螺纹 THREADE E	法兰型号 FLANGE SIZE	尺寸 DIMENSIONS				
			I	d1	A	B	S1
1JFS4-08	U3/4"X16	1/2"	7.9	31.7	25	38	19
1JFS4-10-08	U7/8"X14	1/2"	7.9	31.7	27	39	22
1JFS4-10-12	U7/8"X14	3/4"	8.9	41.3	27	40.1	22
1JFS4-12	U1.1/16"X12	3/4"	8.9	41.3	33	40.1	27
1JFS4-12-16	U1.1/16"X12	1"	8.9	41.3	37	47	33
1JFS4-16	U1.5/16"X12	1"	9.6	47.6	37	47	33
1JFS4-16-12	U1.5/16"X12	3/4"	9.6	47.6	37	45	33
1JFS4-16-20	U1.5/16"X12	1.1/4"	9.6	47.6	40	52	44
1JFS4-20	U1.5/8"X12	1.1/4"	10.4	54	40	52	44
1JFS4-20-16	U1.5/8"X12	1"	10.4	54	40	52	44
1JFS4-20-24	U1.5/8"X12	1.1/2"	10.4	54	40	60.5	44
1JFS4-24	U1.7/8"X12	1.1/2"	12.7	63.5	47	27.5	53

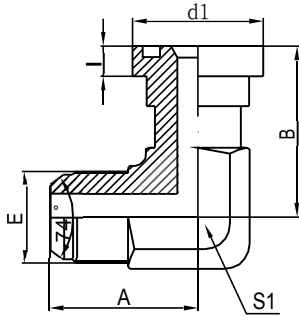

# 1JFS9

90° 美制JIC外螺纹74° 外锥/重系列法兰  
 90° JIC MALE 74° CONE/S-ERIES FLANGE

代号 PART NO.	螺纹 THREADE	法兰型号 FLANGE SIZE	尺寸 DIMENSIONS				
	E		I	d1	A	B	S1
1JFS9-08	U3/4"X16	1/2"	7.9	31.7	33	44	19
1JFS9-10-08	U7/8"X14	1/2"	7.9	31.7	37	46	22
1JFS9-10-12	U7/8"X14	3/4"	8.9	41.3	37	54.1	22
1JFS9-12	U1.1/16"X12	3/4"	8.9	41.3	40	54.1	27
1JFS9-12-16	U1.1/16"X12	1"	8.9	41.3	49	60.2	33
1JFS9-16	U1.5/16"X12	1"	9.6	47.6	49	60.2	33
1JFS9-16-12	U1.5/16"X12	3/4"	9.6	47.6	49	57	33
1JFS9-16-20	U1.5/16"X12	1.1/4"	9.6	47.6	57	66.5	44
1JFS9-20	U1.5/8"X12	1.1/4"	10.4	54	57	66.5	44
1JFS9-20-16	U1.5/8"X12	1"	10.4	54	57	65	44
1JFS9-20-24	U1.5/8"X12	1.1/2"	10.4	54	57	79.3	44
1JFS9-24	U1.7/8"X12	1.1/2"	12.7	63.5	57	79.3	48

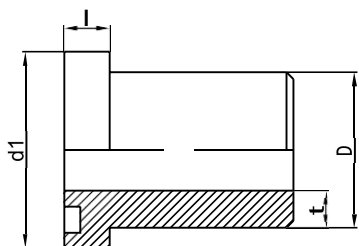

# 1FLW

轻系列法兰/焊接管  
L-SERIES FLANGE/BUTT-WELD TUBE

代号 PART NO.	法兰型号 FLANGE SIZE	DXt	尺寸 DIMENSIONS				
			l	d1	D		
1FLW-08-16X2	1/2"	16x2	7	30.2	16		
1FLW-08-20X2.5	1/2"	20x2.5	7	30.2	20		
1FLW-12-25X3	3/4"	25x3	7	38.1	25		
1FLW-16-25X3	1"	25x3	8.2	44.4	25		
1FLW-16-28X3	1"	28x3	8.2	44.4	28		
1FLW-16-30X4	1"	30x4	8.2	44.4	30		
1FLW-16-38X5	1"	38x5	8.2	44.4	38		
1FLW-20-25X3	1.1/4"	25x3	8.2	50.8	25		
1FLW-20-30X4	1.1/4"	30x4	8.2	50.8	30		
1FLW-20-38X5	1.1/4"	38x5	8.2	50.8	38		
1FLW-20-42X6	1.1/4"	42x6	8.2	50.8	42		
1FLW-24-38X4	1.1/2"	38x4	8.2	60.3	38		
1FLW-24-42X6	1.1/2"	42x6	8.2	60.3	42		
1FLW-24-45X5	1.1/2"	45x5	8.2	60.3	45		
1FLW-24-50X6	1.1/2"	50x6	8.2	60.3	50		
1FLW-32-55X5	2"	55x5	9.8	71.4	55		
1FLW-32-60X8	2"	60x8	9.8	71.4	60		
1FLW-40-65X6	2.1/2"	65x6					
1FLW-40-70X7.5	2.1/2"	70x7.5					
1FLW-48-80X6	3"	80x6					
1FLW-48-90X8	3"	90x8					



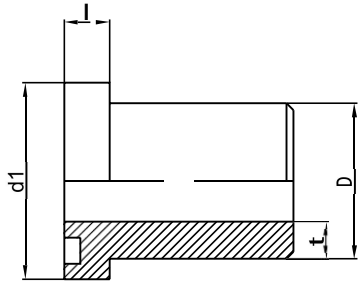

# 1FSW

重系列法兰/焊接管  
S-SERIES FLANGE/BUTT-WELD TUBE

代号 PART NO.	法兰型号 FLANGE SIZE	DXt	尺寸 DIMENSIONS				
			I	d1	D		
1FSW-08-16X2	1/2"	16x2	7.9	31.7	16		
1FSW-08-20X2.5	1/2"	20x2.5	7.9	31.7	20		
1FSW-12-16X2	3/4"	16x2	8.9	41.3	16		
1FSW-12-20X2.5	3/4"	20x2.5	8.9	41.3	20		
1FSW-12-25X4	3/4"	25x4	8.9	41.3	25		
1FSW-16-25X3	1"	25x3	9.6	47.6	25		
1FSW-16-30X4	1"	30x4	9.6	47.6	30		
1FSW-16-38X5	1"	38x5	9.6	47.6	38		
1FSW-20-25X3	1.1/4"	25x3	10.4	54	25		
1FSW-20-30X4	1.1/4"	30x4	10.4	54	30		
1FSW-20-38X5	1.1/4"	38x5	10.4	54	38		
1FSW-20-42X6	1.1/4"	42x6	10.4	54	42		
1FSW-24-38X5	1.1/2"	38x5	12.7	63.5	38		
1FSW-24-45X6.5	1.1/2"	45x2.5	12.7	63.5	45		
1FSW-24-48X8	1.1/2"	48x8	12.7	63.5	48		
1FSW-24-50X8	1.1/2"	50x8	12.7	63.5	50		
1FSW-32-60X8	2"	60x8	12.7	71.4	60		
1FSW-32-60X10	2"	60x10	12.7	71.4	60		

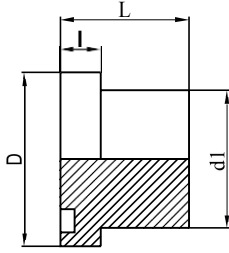

# 4FL

轻系列法兰堵头  
L-SERIES FLANGE PLUG

代号 PART NO.	法兰型号 FLANGE SIZE	尺寸 DIMENSIONS					
		D	d1	l	L		
4FL-08	1/2"	30.2	24	7	16		
4FL-12	3/4"	38.1	31.5	7	17		
4FL-16	1"	44.4	38	8.2	17		
4FL-20	1.1/4"	50.8	43	8.2	17		
4FL-24	1.1/2"	60.3	50	8.2	19		
4FL-32	2"	71.4	62	9.8	19		
4FL-40	2.1/4"	84.1	74	9.8	40		
4FL-48	3"	101.6	90	9.8	45		

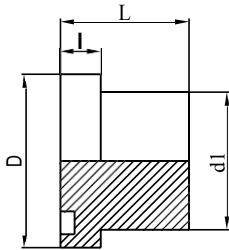

# 4FS

重系列法兰堵头  
S-SERIES FLANGE PLUG

代号 PART NO.	法兰型号 FLANGE SIZE	尺寸 DIMENSIONS					
		D	d1	l	L		
4FS-08	1/2"	31.7	24	7.9	18		
4FS-12	3/4"	41.3	32	8.9	18		
4FS-16	1"	47.6	38	9.6	18		
4FS-20	1.1/4"	54	44	10.4	18		
4FS-24	1.1/2"	63.5	51	12.7	20		
4FS-32	2"	79.4	67	12.7	30		

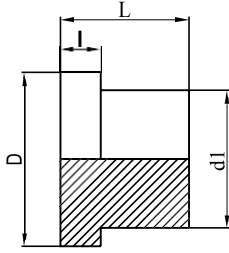

# 4FL-M

轻系列平面法兰堵头  
L-SERIES FLANGE PLUG

代号 PART NO.	法兰型号 FLANGE SIZE	尺寸 DIMENSIONS					
		D	d1	l	L		
4FL-08M	1/2"	30.2	24	7	16		
4FL-12M	3/4"	38.1	31.5	7	17		
4FL-16M	1"	44.4	38	8.2	17		
4FL-20M	1.1/4"	50.8	43	8.2	17		
4FL-24M	1.1/2"	60.3	50	8.2	19		
4FL-32M	2"	71.4	62	9.8	19		
4FL-40M	2.1/4"	84.1	74	9.8	40		
4FL-48M	3"	101.6	90	9.8	45		

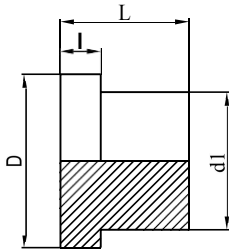

# 4FS-M

重系列平面法兰堵头  
S-SERIES FLANGE PLUG

代号 PART NO.	法兰型号 FLANGE SIZE	尺寸 DIMENSIONS					
		D	d1	l	L		
4FS-08M	1/2"	31.7	24	7.9	18		
4FS-12M	3/4"	41.3	32	8.9	18		
4FS-16M	1"	47.6	38	9.6	18		
4FS-20M	1.1/4"	54	44	10.4	18		
4FS-24M	1.1/2"	63.5	51	12.7	20		
4FS-32M	2"	79.4	67	12.7	30		

# 声 明

本产品目录所采用之图样只作参考之用,其尺寸和比例可能与实际产品有差异.所列产品并非本公司之全部产品,如客户对其它产品感兴趣,请直接与本公司联系.

本公司出版此目录时已尽量力求准确,但为改良及发展产品,可能会对产品规格作出修改,而未及在本书中注明,本公司并且保留权利, 在日后对产品之设计,规格作出更改或停止生产某种产,而恕不另行通知.

## NOTES

The drawings in this catalogue are for reference only, and their dimensions and proportions may be a little different from those of the real products. Products included in this catalogue don't refer to all , so if customers are interested in other products, please don't hesitate to contact our company for further information.

Our company has made much effort to record the correct data in this publication. However, in order to promote our products, we may make some changes of their size or description, which haven't been shown yet. We reserve the rights for explanation, but sorry for no further notice to customer the change of products' design, description or even stop of some products' manufacture in future.